



[Visit Suncam.com for more courses](http://www.suncam.com)

Continuing Education Course #258
An Introduction to
the Analysis and Design of Bolted Connections

1. Which of the following describes the distance, measured along the long axis of the fastener, between the same points on two sequential threads?
 - a. minor diameter
 - b. major diameter
 - c. pitch
 - d. thread angle
2. The Unified Standard Thread is available in different tolerance classes. A tolerance class 2A would indicate which of the following?
 - a. Standard internal thread
 - b. Standard external thread
 - c. Close internal thread
 - d. Close external thread
3. A hex bolt designation is given by 7/8-14 UNC-2A. What does the number 14 in the designation represent?
 - a. 14 threads per inch
 - b. 14 mm pitch between threads
 - c. Bolt length of 1.4 inches
 - d. Bolt length of 14 mm
4. SAE bolt grades are designated with radial line markings on the bolt head. A SAE bolt with 3 radial markings indicates which grade of bolt?
 - a. Grade 5
 - b. Grade 8
 - c. Grade 2
 - d. Grade 3
5. Structural bolt classifications are defined by which of the following?
 - a. International Organization for Standardization
 - b. American Society of Safety Engineers
 - c. American Society for Testing and Materials
 - d. Society of Manufacturing Engineers
6. The properties and geometry of a Grade 8 SAE bolt and a A325 ASTM bolt are identical, and the two are completely interchangeable.
 - a. True
 - b. False

7. A metric bolt has a class designation number of 10.9 stamped on the bolt head. What is the approximate minimum tensile strength of the bolt in MPa?

- a. 100
- b. 1,000
- c. 10
- d. 10,000

8. Which of the following is NOT true about coatings for threaded fasteners?

- a. Coatings are used to improve resistance to corrosion
- b. Coatings significantly increase the bolt's strength properties
- c. Hot dip galvanized coatings have a rougher finish compared to zinc plated bolts
- d. All statements are true

9. Galvanic corrosion is an electrochemical process that occurs due to the contact between dissimilar metals.

- a. True
- b. False

10. Which bolt type has a squared neck shape to keep the bolt from turning when tightened?

- a. Hex head cap screw
- b. Carriage bolts
- c. Machine screw
- d. Socket head cap screw

11. Which of the following statements is true about washers?

- a. Washers distribute the axial load from the bolt over a larger area
- b. Washers protect the surface of the plates from being damaged as the bolt is tightened
- c. Washers span an oversize clearance hole
- d. All statements are true

12. Which joint type subjected to direct loading can have plate bending due to the fact that the loads do not align?

- a. Slip resistant joints
- b. Slip critical joints
- c. Lap joints
- d. Butt joints

13. Which load rating represents a value of approximately 85 – 95% of the yield strength and represents the safe usable tensile load for the bolt?

- a. Proof load
- b. Tensile strength
- c. Shear resistance
- d. Bearing load

14. Based on tension-type shear tests, the allowable shear stress is approximately what percentage of the material's tensile strength? Assume threads excluded from the shear plane.

- a. 25%
- b. 62%
- c. 90%
- d. 43%

15. In slip critical joints, the bolts are not subjected to shear and no bearing stress occurs on the plates.

- a. True
- b. False

16. Which of the following is a method for developing fully tensioned bolts?

- a. Turn-of-the-nut method
- b. Calibrated wrench method
- c. Using direct tension indicators
- d. All of the above

17. LRFD specifications have a preferred minimum bolt spacing equal to

- a. 3 times the bolt diameter
- b. 1.5 times the bolt diameter
- c. 5 times the bolt diameter
- d. 4 times the bolt diameter

18. Standard size bolt holes will have a diameter how much larger than the bolt diameter?

- a. 3/16 inch
- b. 1/16 inch
- c. 1/32 inch
- d. 1/4 inch

19. One mode of failure for a lap joint is shear of the bolts. Based on the LRFD method, what is the resistance factor used for bolt shear?

- a. 0.65
- b. 0.9
- c. 0.75
- d. 0.8

20. Bearing stress is calculated using the applied load divided by the projected area. The projected area is defined as which of the following?

- a. Bolt diameter times plate thickness
- b. 70% of bolt area
- c. Net area of the plate
- d. Bolt area times the number of shear planes

21. The clevis shown contains a single bolt that carries a load of $P = 13$ kips. What is the minimum diameter bolt required if the nominal shear strength of the bolt is 60 ksi? Assume threads are excluded from the shear plane.

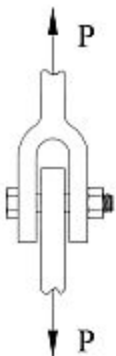

- a. 1/2 inch
- b. 1/4 inch

- c. 5/8 inch
- d. 1 inch

22. The two 1/2 inch thick plates shown are connected by two 1/2 inch diameter bolts. What is the approximate design strength for plate tear located through the bolt line? The plates have a yield strength of 36ksi and an ultimate strength of 58 ksi. Assume standard size holes.

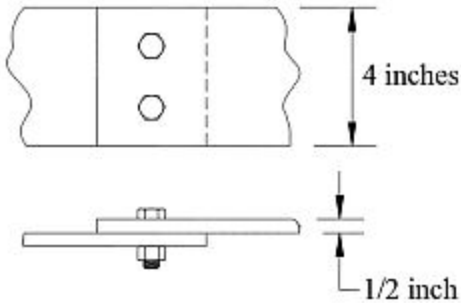

- a. 39 kips
- b. 75 kips
- c. 52 kips
- d. 63 kips

23. An eccentric connection with bolts subjected to eccentric shear has an applied load of 40 kips acting at a distance of 5 inches from the centroid of the bolt group. The connection has a total of 4 bolts. What is the maximum direct load on a single bolt?

- a. 40 kips
- b. 10 kips
- c. 8 kips
- d. 50 kips

24. What is the location of the centroid in the x direction \bar{x} for the bolt group shown?

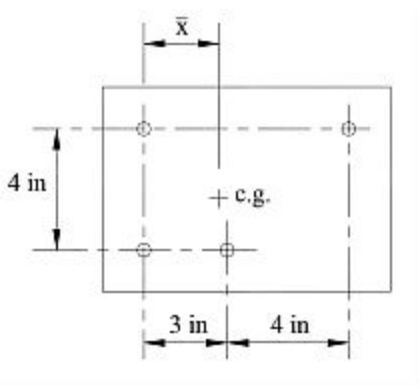

- a. 3.5 inches
- b. 4 inches
- c. 2 inches
- d. 2.5 inches

25. For the eccentric connection shown, what is the resultant force on the maximally stressed bolt?

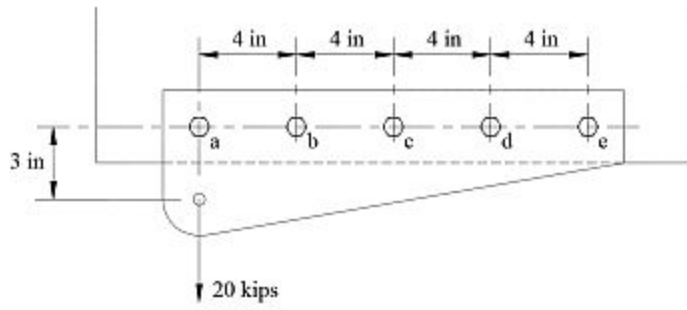

- a. 4 kips
- b. 8 kips
- c. 12 kips
- d. 7 kips

[Purchase this course on Suncam.com](http://Suncam.com)