

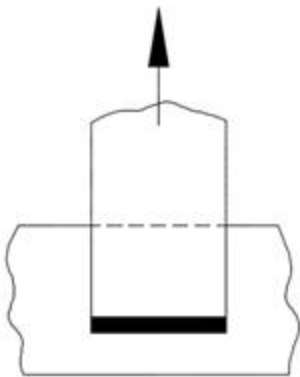

[Visit Suncam.com for more courses](http://www.suncam.com)

Continuing Education Course #254  
A Practical Design Guide for Welded Connections  
Part 2 - Analysis and Design of Welded Connections

1. Which of the following is a good general design consideration for welded joints?
  - a. Place welds in low stress areas to reduce the loading on the welded joint
  - b. Symmetrically located welds are good for reducing distortion
  - c. Avoid stress changes in a weld
  - d. All of the above
2. In general, connections using groove welds will be less expensive than using fillet welds.
  - a. True
  - b. False
3. In the LRFD method, a multiplier is used to account for material strength uncertainties and reduce the theoretical ultimate strength. The multiplier is known as the
  - a. electrode strength factor
  - b. resistance factor
  - c. reinforcement factor
  - d. transverse factor
4. Which of the following is true about groove weld reinforcement?
  - a. Reinforcement only occurs on double V groove welds
  - b. Reinforcement reduces the strength of a joint subjected to static loading
  - c. Reinforcement causes a stress concentration and is bad for joints subjected to repeated or vibrating loads
  - d. All of the above
5. The weld shown is subjected to what type of loading?



- a. Combined bending and torsion
- b. Combined shear and torsion

- c. Parallel (longitudinal) loading
- d. Transverse loading

6. What is the effective throat thickness of a 3/8" fillet weld?

- a. 0.225 inches
- b. 0.375 inches
- c. 0.265 inches
- d. 0.530 inches

7. Two 3/8" plates are to be welded with fillet welds in a lap joint. According to LRFD requirements, the minimum weld size would be

- a. 3/16 inch
- b. 1/4 inch
- c. 1/8 inch
- d. LRFD does not give a minimum weld size requirement

8. The welded connection shown used E60 electrode. Which of the following most closely gives the total capacity of the weld? Disregard the calculation of design capacity of the plate.

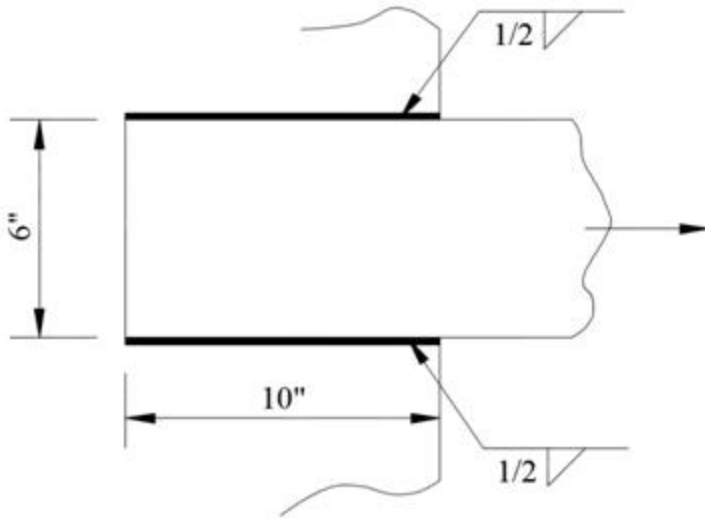

- a. 191 kips
- b. 95 kips
- c. 223 kips
- d. 115 kips

9. Which of the following statements is NOT true about weld distortion?

- a. Symmetrically located welds will reduce distortion.
- b. Intermittent welding increases distortion
- c. Distortion occurs due to the thermal expansion and contraction of weld material and adjacent base material during the welding process.
- d. Over welding causes distortion

10. A 2 1/2 inch diameter solid steel round bar is welded to a steel plate as shown using E70 electrode. What is the strength of the fillet weld?

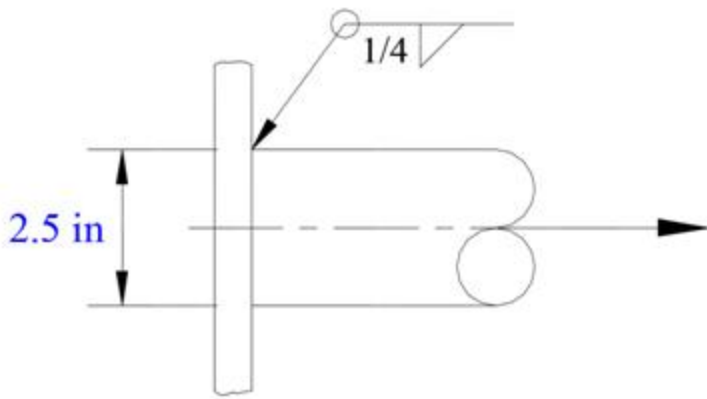

- a. 14.9 kips
- b. 23.6 kips
- c. 37.5 kips
- d. 43.7 kips

11. A 1/2 inch fillet weld (E90) that is direct loaded (shear only) has a design strength of

- a. 14.32 kips/in
- b. 11.14 kips/in
- c. 10.74 kips/in
- d. 7.16 kips/in

12. What is the value of the resistance factor, according to LRFD requirements, for fillet welds with shear on the effective area?

- a. 0.65
- b. 0.9
- c. 0.6
- d. 0.75

13. Consider the eccentrically loaded welded connection shown. The center of gravity of the weld group is indicated as C.G. and the distances from the center of gravity to different points on the weld group are given along the dashed lines. Which point in the weld will have the maximum stress?

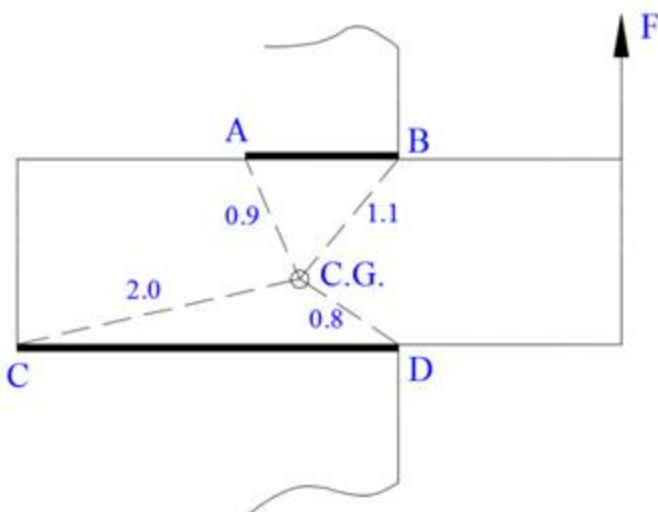

- a. Point A
- b. Point B
- c. Point C
- d. Point D

14. Determine the minimum required fillet weld size for the eccentric connection shown using E60 electrode.

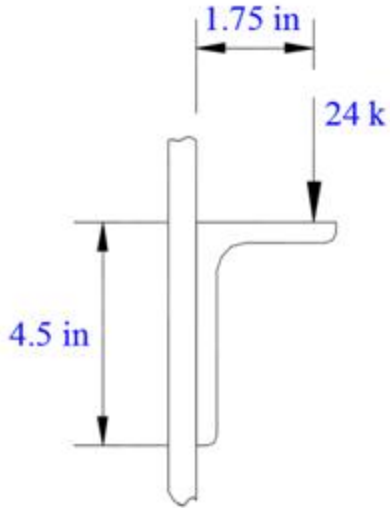

- a. 3/16 inch
- b. 1/4 inch
- c. 5/16 inch
- d. 3/8 inch

15. A structural angle is to be welded to the plate as shown. What is the value of the force  $F_2$ ?

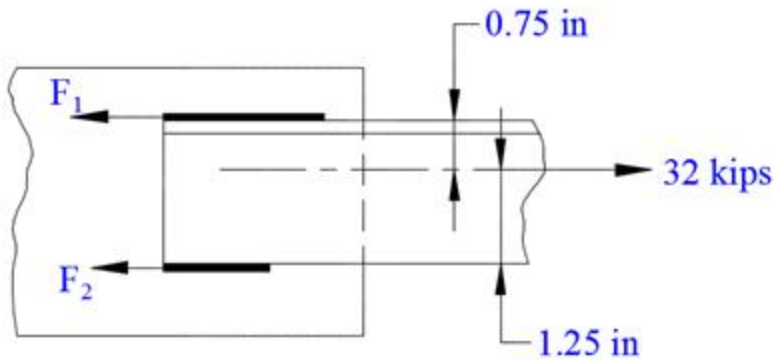

- a. 20 kips
- b. 15 kips
- c. 12 kips
- d. 8 kips

[Purchase this course on Suncam.com](http://Suncam.com)