



Introduction to the Design of Wood Trusses
A SunCam online continuing education course

Introduction to the Design of Wood Trusses

By Derek L. Rhodes, P.E.



Introduction to the Design of Wood Trusses
A SunCam online continuing education course

Purpose:

Metal plated wood trusses have become very popular for wood frame construction, especially in the home building industry. The purpose of this document is to provide an introduction to the most significant concepts relating to the design, manufacture, and erection of metal plated wood trusses and their application to residential and light commercial construction.

Advantages of Metal Plated Wood Trusses:

Metal plated wood trusses are engineered products that are manufactured in a controlled environment. Wood trusses provide the architect or building designer greater flexibility in the design of the structure than conventionally framed construction. The design is not as limited with bearing wall locations which enables longer spans and greater ability to shape complicated roof and ceiling profiles. These pre-manufactured wood trusses provide for a quicker construction schedule and a lower material cost. The use of wood trusses can earn points towards a Green certification for the environmentally conscious owner due to the material optimization and the minimal waste in a controlled manufacturing operation.

This document will first provide an over view of the metal plated wood truss industry by providing definitions of terms commonly used in the industry followed by a section on the responsibilities of the various parties involved in the specifying, design, manufacture, and erection of wood trusses. The important issue of truss bracing is discussed to provide a better understanding of the potential hazards involved in the use of wood trusses. The remainder of the document is devoted to considerations during the specifying and design phases of construction.

Definitions:

As with any profession, certain words develop special meaning that those outside the industry may not fully understand. The following is a list of terms commonly used in the metal plated wood trusses industry:

General Definitions:

Truss: An assemblage of structural elements shaped into triangles for the purpose of carrying a load over a certain span.

Truss Plate: A galvanized steel plate that has been punched in such a way as to form sharp teeth that can be embedded in wood. The most common truss plate thickness is 20 gauge. 18 and 16 gauge truss plates are also available.

Metal Plated Wood Truss: An assemblage of wood structural members usually connected in the shape of triangles using steel truss plates and manufactured in a controlled factory setting. Technically, the term truss would not necessarily apply to all shapes that can be formed with wood members and truss plates because many shapes use rectangles instead of triangles, but in the common lingo a wood truss would be any assemblage of wood members connected with steel plates that is manufactured in a factory for a specific application. The pieces of the truss are arranged to follow the required roof or floor and ceiling profile.



Introduction to the Design of Wood Trusses
A SunCam online continuing education course

Pitch or Slope: An expression of the angle of the outside members of a truss to define either the roof or ceiling profile. Usually, the pitch is in terms of the number of inches of vertical rise in a 12" horizontal run. An example would be a 6:12 pitch would have 6" of vertical rise for every 12" of horizontal run which would also equal a 50% slope or 26.56° above horizontal.

Gable End: An area of the roof system where a vertical wall projection extends to meet the roof planes.

Hip End: An area of the roof where the roof planes begin at the top of each wall.

Bearing: The structural support for the truss such as a structural wall, beam, or another truss. The truss may be on top of the structural support or connect to the support using a mechanical connection such a steel hanger.

Span: The distance between bearings. When the truss has only two bearings, the span would be the outside distance between the bearings and often matches or is close to the overall length of the truss.

Tributary Area: The calculated horizontal projected area supported by each truss. The tributary area for most trusses is the span of the truss times its on-center (o.c.) spacing. The tributary area for a girder truss is the sum of all the tributary areas of the supported trusses plus half the area to the next truss. For example, the Girder1 truss shown in the Roof Truss Placement Plan (Figure 1) has a span of 16'. This Girder1 truss supports seven Common2 trusses that have a 30' span and are set at 2' o.c. Each Common2 truss would have a tributary area of 60 ft^2 . Girder1 would then have a tributary area of $(7)(60 \text{ ft}^2) + (1')(16')$ which equals 436 ft^2 .

Jig: An established pattern or guide for assembling the pieces of a truss. The jig may be either manually or automatically established for each truss type and allows multiple similar trusses to be consistently manufactured.



Introduction to the Design of Wood Trusses
 A SunCam online continuing education course

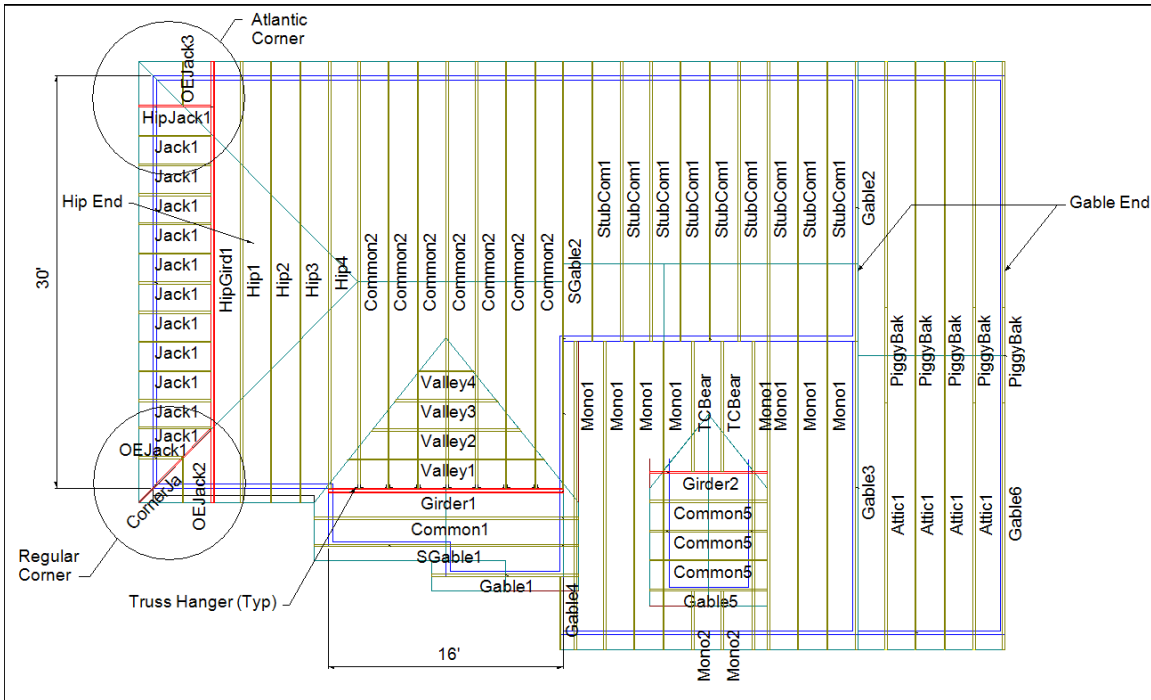

Figure 1: Roof Truss Placement Plan

Truss Types:

A sample roof truss placement plan which would accompany most truss design packages is shown in Figure 1 and an isomeric view is shown to the right in Figure 2 for a single family residence. The trusses on the roof truss placement plan are labeled by truss type. For each truss type listed below, the corresponding truss or trusses if shown on the truss placement plan is in parenthesis after the description along with a small diagram of the truss profile.

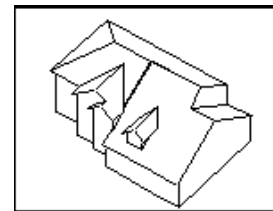
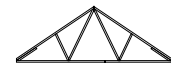

Figure 2: Isomeric

Roof Truss: A wood truss assembled with nominal 2x lumber in the edgewise orientation so that the thickness of the truss is 1 1/2". Sometimes, an edgewise truss is used in floor applications. This is commonly called "A roof truss used as a floor" because the truss needs to be manufactured on the factory roof tables like other roof trusses.



Floor Truss: A wood truss assembled with nominal 2x4 lumber in the flatwise orientation so that the thickness of the truss is 3 1/2". In some flat roof applications, a flatwise truss is used. This may commonly be called "A floor truss used as a roof" because the truss needs to be manufactured on the factory floor tables like other floor trusses.



Attic Frame or Attic Truss: An assemblage of wood members that follow the required roof and ceiling profile while leaving a large rectangular opening near the middle of the truss for the purposes of framing a room. An attic frame is not technically a truss because it is not triangulated,

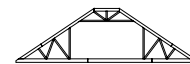



Introduction to the Design of Wood Trusses
 A SunCam online continuing education course

but because an attic frame is built in the same factory, with the same material, and with the same design considerations as a wood truss, the word truss is commonly associated with an attic frame. (Attic1)

Common Truss: A basically symmetric triangular shaped wood truss. (Common1, Common2)

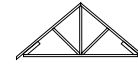

Mono Truss: A roof truss that takes the shape of a right triangle, usually half or less the size of a Common Truss. (Mono1, Mono2)



Girder Truss: A truss that supports other framing members or extra load, including but not limited to other trusses, beams, or conventional framing. A girder truss usually consists of larger lumber sizes and multiple individual trusses or plies connected together to act as a single unit. (Girder1, Girder2)

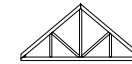

Hip Truss: A roof truss with a flat region on the top to be used in a hip end. (Hip1, Hip2, Hip3, Hip4)

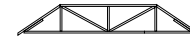

Hip Girder Truss: A hip truss that supports other framing members to complete the framing of a hip end. (HipGird1)

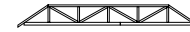

Jack Truss: A short mono truss, usually 8' in length or less and set perpendicular to the hip girder truss. (Jack1)



Hip Jack Truss: A Jack truss with a flat region on top. (HipJack1)

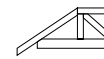

Corner Jack: A mono truss set at angle to the hip girder truss along the intersection of two roof planes. The angle to the hip girder is determined by the pitches of the two adjoining roof planes. If the pitches are the same then the angle will be 45°. (CornerJa)

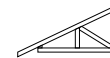

Gable Truss: An assemblage of members that is usually placed on top of a wall at the end of a run of trusses and matches the profile of the adjacent truss. Instead of forming triangles, the inside members called studs are all vertical and/or horizontal. The gable truss usually has sheathing applied to one face that matches the sheathing used in the wall framing. (Gable1, Gable2, Gable3, Gable4, Gable5, Gable6)

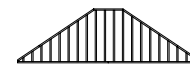

Structural Gable Truss: A truss that is a combination of a roof truss and a gable truss. The structural gable truss is usually partially supported by a parallel wall. One method of design has the vertical studs fit between the diagonal members. (SGable1, SGable2) Another method of design uses two parallel sloping members to separate the roof truss section from the gable section. (Refer to Figure 5)



Valley Truss: A truss similar to a gable truss but that is supported by other trusses or framing members below and is usually set perpendicular to the supporting truss. A valley truss is used to complete necessary over framing. (Valley1, Valley2, Valley3, Valley4)





Introduction to the Design of Wood Trusses
A SunCam online continuing education course

Piggy-Back or Cap Truss: When a roof truss is too tall to ship, the truss is modified to have a flat region on top so it is just like a hip truss, and a shorter truss called a piggy-back is designed to fit on top of the base truss to complete the shape. The piggy-back truss is usually parallel to and sits directly over the base truss. (PiggyBak)

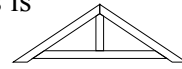

Floor ladder or Knee-wall: A truss similar to a roof gable truss but it is built on the floor table in the flatwise orientation with vertical stud members in the middle. The floor ladder usually needs to be continuously supported over its entire length.

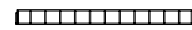

Top Chord or Tail Bearing: A situation where one bearing point is at a lower height than the bottom chord member and the sloping top chord member, usually a larger size dimensional lumber, extends to the bearing. (TCBear)

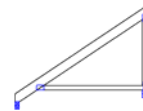

Truss Term Definitions:

Top Chord: The top most members that define the roof or floor profile. The top chord members are usually continuous from one end of the truss to the other end. In a simple span situation where there are only 2 bearings located at the ends of the truss, the top chord is in compression under gravity loads and requires continuous lateral bracing such as roof sheathing to prevent the top chord from buckling.

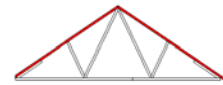

Bottom Chord: The bottom most members that define the lower or ceiling profile. The bottom chord members are usually continuous from one end of the truss to the other. In a simple span situation, the bottom chord may go into compression only in uplift load cases and usually requires less lateral bracing than the top chord.

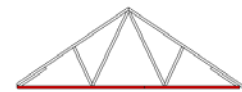

Webs: The interior members of the truss that are used to form triangles and are required to provide intermediate structural support for the top and bottom chord.

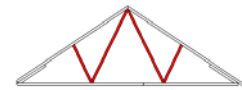

Continuous Lateral Restraint (CLR): A member that is attached to a predominantly compression web to reduce the effective buckling length of the web. The CLR may be dimensional lumber applied perpendicular to the web to attach and brace the same web in multiple trusses in a run or it may be dimensional lumber applied along the length of the web member to form a T-section if a similar web is not nearby.

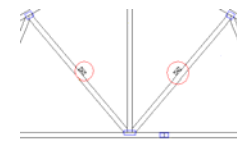

Joint or Panel Point: A location where wood members are joined by a pair of truss plates.

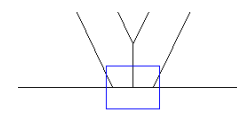

Panel: The region between two joints.

Panel Length: The distance between two joints.



Introduction to the Design of Wood Trusses
A SunCam online continuing education course

Splice: A joint where two top chord or two bottom chord members are joined. A splice is needed when the length of the truss is longer than available dimensional lumber. The splice may occur at the same locations as web members or out in the panel away from webs.

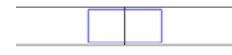

Peak: The highest point on either the top chord or bottom chord profile.

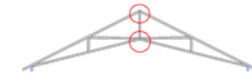

Pitch Break: A point where the top chord or bottom chord profile changes slope.



Heel: The joint or joints at the end of the truss.

Heel Height: The height of the truss at the outside edge of the bearing support or at the end of the bottom chord whichever extends farther. This is a critical dimension for the definition of the roof planes.

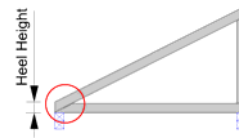

Butt Cut: A small vertical distance at the end of a bottom chord member below the sloping top chord member. The butt cut is required in the manufacturing process to prevent minor variations in the saw blade location from causing a change in the span of the truss.

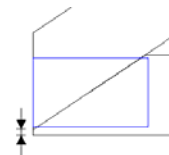

Standard or Nominal Heel: The heel joint where the sloping top chord member is joined to the bottom chord member with only the distance of the butt cut between the top chord and bearing surface.

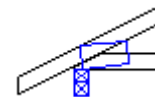

Raised Heel: Any heel where the heel height is more than the Standard Heel. The raised heel allows more insulation to be placed over the outside wall which may be necessary to meet certain codes.

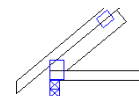

Overhang: The region or distance where a top chord member extends beyond the bottom chord at the end of the truss. This region or a portion thereof can usually be removed from the truss during erection if necessary.

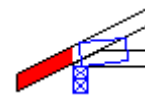

Cantilever: The region or distance the bottom chord extends beyond the bearing point. The top chord usually extends to the end of the bottom chord.

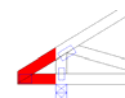

Wedge: A small triangular shaped wood block used for heel reinforcement for nominal or slightly larger heel heights.

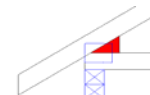



Introduction to the Design of Wood Trusses
A SunCam online continuing education course

Slider: A wood member that runs adjacent to either the top or bottom chord for the purpose of reinforcing the heel. This is applicable for required heel heights taller than a wedge allows but not tall enough for a vertical member.

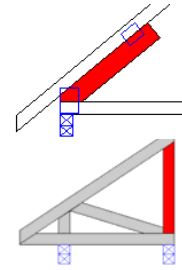

End Vertical: The vertical member used to connect the top chord to the bottom chord on tall heels.

Chase: A rectangular opening in a floor truss for the purpose of allowing the passage of ductwork or other large pipes. The chases across several trusses in a run usually line up so the ductwork may pass through in a straight line. Even when a chase is not required for ductwork, a floating chase is usually still provided to facilitate the manufacturing process with dimensional variances in wood members.

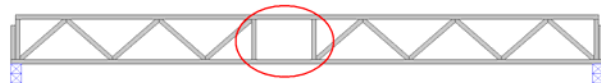

Ceiling Profiles:

Flat Ceiling: The standard truss shape where all the bearings are at the same height with no variation in the bottom chord of the truss between the bearings.

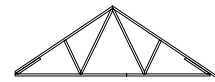

Tray: A partial volume ceiling where a flat section of the bottom chord is raised with sloping sides.

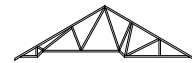

Box: A partial volume ceiling where a flat section of the bottom chord is raised with vertical sides.

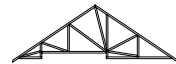

Cathedral: A partial volume ceiling where the two members of the bottom chord slope up to a peak.

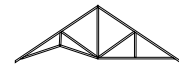

Vault: A partial volume ceiling where one side of the ceiling slopes up while the other side is vertical.

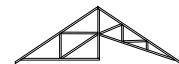

Plant Shelf: A vault ceiling profile where the bottom chord of the flat portion extends into the volume ceiling area.

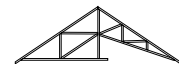

Scissor: A full volume ceiling where the bottom slopes up from both bearings to a peak in the middle.





Introduction to the Design of Wood Trusses
A SunCam online continuing education course

Responsibilities:

At the time of writing this course, the governing document for the metal plated wood truss industry is the ANSI/TPI 1-2002 (TPI) standard. However, the 2007 standard has been published and is in the process of being implemented. Chapter 2 of the stated standard addresses the responsibilities of the Building Designer, Truss Designer, Truss Manufacturer, and Contractor involved in the design and construction process.

The Building Designer, who may be an architect or engineer, is in charge of planning the overall structure and is responsible for communicating the design criteria for the structure to the Truss Designer. The design criteria include all appropriate dead and live loads, the wind speed, and ground snow load. The Building Designer also needs to provide the location of all bearing surfaces and the shape of the roof including roof slopes and heel heights. A key part of the Building Designer's responsibility is to design the temporary and permanent truss bracing of the truss system which is extremely important for the structural integrity. The truss bracing topic will be addressed in more detail later in this document.

The Truss Designer uses the design criteria provided by the Building Designer to develop a series of trusses that match the roof and ceiling profile in order to transfer the superimposed loads to the bearing surface. The Truss Designer provides information about each truss including span, height, pitch, location of joints, lumber and plate sizes, axial forces in all members, and reactions at each bearing. The Truss Designer also provides the locations where individual truss members require a Continuous Lateral Restraint (CLR) to prevent the member from buckling out of plane. This will be discussed further in the bracing section. The Truss Designer also provides a Truss Placement Plan to show the location of each truss and specify the Truss to Truss connections.

As a special note to Florida Engineers, the Florida Laws and Rules make a distinction between a Truss Design Engineer and a Truss System Engineer. A Truss Design Engineer is a Delegated Engineer that would be the same as a Truss Designer under the TPI code. A Truss System Engineer is also a Delegated Engineer but is responsible for the lateral bracing of the trusses. Similarly, other jurisdictions may have other provisions for the design of the truss bracing system.

The Truss Manufacturer uses the information provided by the Truss Designer to manufacture the trusses and deliver the package to the jobsite. The Truss Manufacturer provides all the printed materials for the Contractor. The position of Truss Technician is not mentioned in the TPI but is usually a person employed by the Truss Manufacturer and who works under the direction of the Truss Designer to prepare the truss shop drawings and Truss Placement Plan.

The Contractor is responsible for safely erecting the trusses. It is very important for the Contractor to follow both the temporary and permanent bracing plans for the safety of the personnel involved in the construction as well as the final occupants of the structure. In the absence of a detailed bracing plan, the Contractor should refer to the Building Component Safety Information (BCSI) document that is jointly published by the Truss Plate Institute and Structural Building Components Association (SBCA).



Introduction to the Design of Wood Trusses
A SunCam online continuing education course

Truss Bracing:

One of the most important and least understood concepts in dealing with wood trusses is the issue of bracing. Since roof trusses are built in the edgewise orientation, many members act as long slender columns and can buckle out-of-plane very easily. Member bracing is not really a factor on floor trusses because the panels are short and the truss is in the flatwise orientation, however floor sheathing applied to the top chord is still necessary to keep the entire floor truss from buckling. Due to the severity of the issue, the remainder of the bracing discussion will focus on roof trusses.

The highest compression forces for a simply supported roof truss under normal gravity loads are found in the top chord, and therefore proper bracing of the top chord is of the utmost importance. The roof sheathing for most residential structures is applied directly to the top chord creating a roof diaphragm for the continuous lateral support of the top chord. There are several cases where the roof sheathing may not be directly applied to the top chord, and the Building Designer must consider these cases carefully to make sure the top chord is properly braced.

One such case is where there is over-framing to provide an architectural detail such as a valley. Valley trusses, if properly connected to the top chord, may provide adequate support of the top chord of the base truss. The picture in Figure 3 shows the top chord of several trusses under some valley trusses where the valley trusses were not properly connected to top chord and the top chords buckled. If rafter framing is used in the over-framing, the Contractor should install roof sheathing to the top chord in this area.



Figure 3: Buckled truss top chord

Another case is in the use piggy-back trusses when the base trusses are too tall to ship. The flat area of the top chord of base truss must be prevented from buckling out-of-



Figure 4: Structural Failure

plane. The photo in Figure 4 shows the collapse of the trusses for a church where the flat area of the base truss was not properly restrained. The standard detail is to connect the flat area of the base trusses using 2x4 members on the flat, called purlins, at 2' o.c., and the piggy-back trusses then sit on top of the 2x4 purlins. The problem with this detail is that there is no way to transfer the lateral forces to the roof diaphragm, and the rectangular shape created by the purlins on the top chord allows all of the trusses to buckle in the same direction.

Proper installation of the purlins would also have diagonal bracing to transfer the lateral forces to the roof diaphragm. Another option that has been floated in the industry is to sheath the flat area of the base like the rest of the truss. If this option is used then the Building Designer should consider the issue of proper ventilation.



Introduction to the Design of Wood Trusses
A SunCam online continuing education course

A third case has to do with building the over-framing into the base truss. This case usually has an area of the truss where there are two top chords that may be parallel to each other. Figure 5 shows a structural gable truss using the over framing technique. In this case, both top chords need to be restrained.

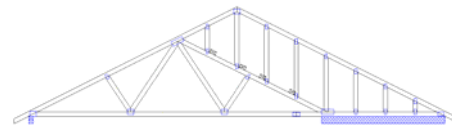

Figure 5: Over Framing built into truss



Figure 6: Webs buckled in unison

In addition to the top chord, certain webs may develop large compression forces and require lateral restraint. A 2x4 continuous lateral restraint (CLR) may be applied to restrain the web member when several identical trusses are adjacent to each other. The issue of rectangular support causing all the members to buckle in unison exists with the CLR as well, so a periodic diagonal brace is also required to transfer the lateral forces to the roof diaphragm. The picture in Figure 6

shows a series of web members that have buckled in unison due to the lack of the diagonal braces. An alternate method of providing lateral restraint for web members involves nailing a second 2x4 along the length of the web. This second 2x4 can be nailed to either the wide or narrow face of web member creating either a wider member or a different section such as a T or L-shape.

In addition to the top chord and webs, the bottom chord may also develop compression forces in situations of load reversal such as in wind load cases or where there is a continuous truss over several bearings. The bottom chord has sufficient lateral support when drywall is applied directly to the bottom chord of the truss. The bottom chord will require lateral restraint with diagonal bracing if the drywall is not directly applied, but the restraint requirements for the bottom chord are usually far less than that of the top chord.

Girder Truss Issues:

Issues dealing with girder trusses are also very important for the overall performance of the structure. The most critical aspect to the design of girder trusses is development of the loads that it supports. For simple applications where a girder truss supports several identical trusses, the loads to be applied to the girder are simply the reactions of the supported trusses. The TPI code (section 7.4.2.1) allows for concentrated loads to be converted to an equivalent uniform load if the supported trusses are spaced less than 34" o.c. The use of uniform loads is common practice in the wood truss industry. It should be noted that it is not recommended to simply do a tributary area calculation for roof trusses. The International Residential Code 2006 (IRC2006) building code has a provision in Table R301.5 footnote G requiring all areas of the roof truss where a box 24" wide by 42" tall could fit above the bottom chord be loaded with 20 psf



Introduction to the Design of Wood Trusses
A SunCam online continuing education course

live load. This extra load is often missed in the load calculations and is not actually known until the supported trusses are designed and the web configuration is determined. For this reason, it is recommended to use the reactions of the supported truss rather than a tributary area calculation for all gravity loads.

In addition to girders that simply support other trusses, there are several other situations that should be considered when developing loads for loading girder trusses such as dormers, cupolas, steeples, mechanical unit weights, and snow drifting. There are special situations where a roof girder truss may be used to support wall or floor loads. Since a Duration of Load (DOL) increase of 1.15 is allowed for snow loads, the DOL must be returned to 1.00 when a roof girder is used to support floors. This DOL change is often missed in the design of the roof girder that supports floor loads.

The TPI 1 code (section 7.4.5) requires that multiple plies of a girder truss be connected together to act as a single unit. For 3-ply or less, the connection may be nails, screws, or other approved fasteners. For 4-ply or more, the addition of bolts is required. However, only one type of fastener may be used for the calculation of the load transfer. For a 4-ply truss, the plies may be connected with nails to transfer the load and the nails must be designed to transfer the full load even though bolts are also required. The bolts must either transfer the load through all the plies by themselves or not be included in the calculation at all. The bolts, however, are required to draw the plies together to make sure there is no gap between the plies and allow the nails to provide the load transfer. The TPI 1 code (paragraph 7.4.2.4) states that the maximum number of plies for a roof girder truss loaded from one side is 5 while a girder that is loaded from both sides or on top may be 6 plies.

Floor truss girders are limited to 2 plies. Due to the width of the floor truss, there are only a limited number of ways to connect the 2 plies of a floor truss girder together. Since standard nails would not penetrate through the first ply, other options are to connect the floor girder plies together using long wood screws or proprietary clips that can transfer the load.

The most common limiting factor as to how much load a common shaped roof girder truss can carry is the area of the bearing surface. The compression perpendicular to grain ($F_{c\perp}$) value controls which is listed in the American Forest and Paper Association National Design Standard (NDS) standard. The NDS does not allow a duration of load increase for the $F_{c\perp}$ value, so the calculation of bearing capacity is simply the $F_{c\perp}$ value times the bearing area. As an example, the $F_{c\perp}$ value for Southern Yellow Pine (SYP) No. 2 is 565 psi, so for a 2-ply (3" width) roof truss with SYP No. 2 on the bottom chord on a 2x4 wall (3.5" bearing length), the bearing capacity is 5,933 lbs. There are proprietary connectors on the market that allow an increase in bearing capacity by more than 2,000 lbs. However, for many regular shaped girder trusses, the bearing capacity is still the limiting factor for the girder design even with the addition of the proprietary connectors. The top plate of the wall may be a different material than the truss itself, and the technician should consider the bearing surfaces to assure adequate bearing capacity. If the proprietary connectors do not add enough bearing capacity, then extra plies should be added. Another option is to increase the size of the bearing by changing the framing lumber in the walls from 2x4 to 2x6 which may reduce the required number of plies of the roof girder and have the added benefit of improved energy efficiency of the structure.



Introduction to the Design of Wood Trusses
A SunCam online continuing education course

The TPI code (section 7.4.3) highlights an additional concern for connections to roof trusses that produce “tension perpendicular to the grain”. A common example of this situation is when a truss hanger that supports another truss is connected to the bottom chord of the girder truss. Paragraph 7.4.3.2.1 states that, when the net force component perpendicular to the grain exceeds 800 lbs, the connection shall extend above the centerline of the carrying member a certain minimum distance based on an equation given in the section. The easiest way to remedy this concern is to size the truss hanger to be the same size as the bottom chord of the girder truss. If the truss hanger is shorter than the height of the bottom chord and the reaction is greater than 800 lbs, then the tension perpendicular to the grain must be evaluated. This provision also affects the truss plates for tension webs. If the net tension force in the web exceeds 800lbs, then the truss plates must be sized to extend the plate the required distance beyond the center of the chord.

Deflection is a common limiting factor for floor girder trusses. The IRC2006 code (Table R301.7) allows floor systems to be designed with L/360 live load deflection and L/240 total load deflection where L is the span of the truss. However, due to performance issues, some truss manufacturers and state building codes tighten the live load deflection limit to L/480. Doubling up the chord members, changing lumber material, and/or adding an extra ply are often used to achieve the deflection criteria.

One item to consider when loading girder trusses is the weight of the girder truss itself. This is a concern because the plate supplier software usually does not add the weight of the truss into the loads. The standard loads usually include the weight of the truss. The standard dead loads range between 17 and 20 psf, with 10 psf on the bottom chord which allows 7 to 10 psf on the top chord for a standard shingle roof. If other roofing materials are used, the design loads must be adjusted appropriately. A standard roof truss with 2x4 top and bottom chords will weigh approximately 6 to 7 lbs per linear foot, but a 4-ply girder with 2x10 bottom chord and 2x6 top chord can weigh up to 40 lbs per linear foot. Most wood trusses are designed at 2’ o.c. However, it is common practice to claim the overlapping tributary area and design the girder truss at 1’ o.c. because the tributary area of the girder overlaps the tributary area of the supported trusses. The problem with claiming this reduction is that now there is not enough dead load to account for the weight of the truss. The recommendation is to design the roof girder truss at 2’ o.c. allowing the extra tributary load to account for the weight of the truss.

Limits of Wood Truss Construction:

Although the use of wood trusses greatly increases the flexibility in the design of the structure, allowing much longer spans than conventional framing, there are some real and practical limits that require consideration. The wood material comes from living trees which has non-isotropic properties and is laden with defects. These properties put wood in a different category than steel and concrete that essentially have the same properties in each direction. Wood is more susceptible to damage due to moisture, insect infestation, excessive heat or internal defects. If, however, wood can be kept dry, away from destroying insects, within a reasonable temperature range and the selected wood pieces minimize lumber defects, then the performance of wood members can be very reliable for a long period of time.



Introduction to the Design of Wood Trusses
A SunCam online continuing education course

These lumber defects are a key issue for the Truss Manufacturer. The grading of lumber from the lumber supplier allows certain size knots, holes, splits, twists, and bows for each specific grade. Once the lumber is cut, however, the otherwise acceptable defects sometimes become unacceptable if a knot, hole, or split occurs at or near a joint where a truss plate must connect one truss member to another. Most Truss Manufacturers will therefore have in-house quality control measures and possibly employ a third party inspector. The TPI provides an inspection service that is used by many manufacturers. Despite tight quality control, some problems will inevitably arise due to lumber quality issues.

It is also important to understand the practical limits of wood trusses from a design standpoint. The overall practical maximum length of a wood roof truss is around 70'. The issue of shipping, handling, erecting, and bracing these long span trusses gets increasingly more difficult with every extra foot in length. Steel trusses become more cost effective for clear spans of this length.

The overall height of the roof truss is limited to 12-14' depending on local shipping laws and permitting requirements. The height may be restricted to as little as 7'-6" if the trusses are to be shipped overseas in a shipping container. If the roof height exceeds the shipping height, the truss technician will usually use a piggy-back truss that is erected on top of the base truss to make up the extra height.

Another consideration for roof trusses is the proximity of the roof and ceiling profiles. As a rule of thumb, the perpendicular distance between the top of the top chord and the bottom of the bottom chord for any place in the interior of the truss should not be less than the clear span of the truss divided by 20. An example of where this rule of thumb may be violated is in the box ceiling truss in Figure 7. Violating this limit could cause joint plating design difficulties, excessive deflection, and issues regarding insulation and ventilation.

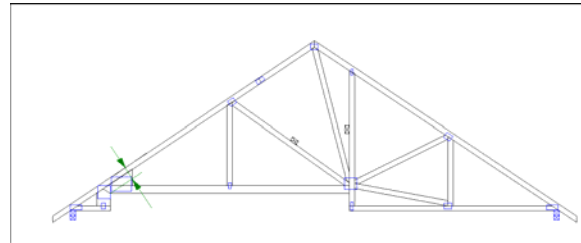

Figure 7: Proximity of roof and ceiling profile.

A 36' clear span truss, as an example, should not have any location except at the heels where the truss is less than 21 1/2" deep. This is not a concern for common trusses, but where there is a volume ceiling, this limit should be considered.

Another similar rule of thumb limit is that for long sloped ceiling chords such as scissors and vaults, the ceiling pitch should not be more than 1/2 the roof pitch. A scissor truss, for example, with a 7:12 roof truss pitch should have only about a 3 1/2:12 ceiling pitch. As the ceiling pitch increases, so does the deflection, and this pitch rule of thumb usually produces desirable results with limited deflection

The physical limit for the overall length of floor trusses for many manufacturers is 40'. The clear span limit is based on a rule of thumb limit of a span-to-depth ratio of 20. For a 16" deep floor truss, as an example, the clear span limit would be 26'-8". Once the span gets greater than 20 times the depth, deflection and vibration become a big concern. As a rule of thumb for floor truss cantilevers, the cantilever span should not exceed 2 times the depth of the floor truss, and the anchor span should be at least 2 times the



Introduction to the Design of Wood Trusses
 A SunCam online continuing education course

length of the cantilever span for light loads and 4 times the length of the cantilever for heavy loads. Figure 8 shows a floor truss with a cantilever.

To reduce deflection and vibration in floor trusses, the use of strong backs is highly recommended and sometimes is required. A strong back consists of a

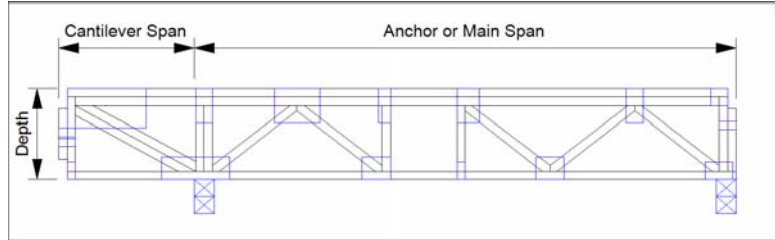

Figure 8: Floor Truss Cantilever.

minimum 2x6 piece of lumber that is installed perpendicular

to the floor trusses across several trusses in the upright position on top of or as close to the bottom chord of the floor truss as possible. TPI 1 (section 7.5.2.4) details strong back requirements. One strong back is required near the center of the floor truss when the vertical deflection due to live loads exceeds 0.67". Two strong backs are required at the 1/3 points of the truss when the vertical deflection due to live loads exceed 0.85", but the spacing of the strong backs shall not exceed 10'. Figure 9 shows a strong back installed through the chase of four similar floor trusses.

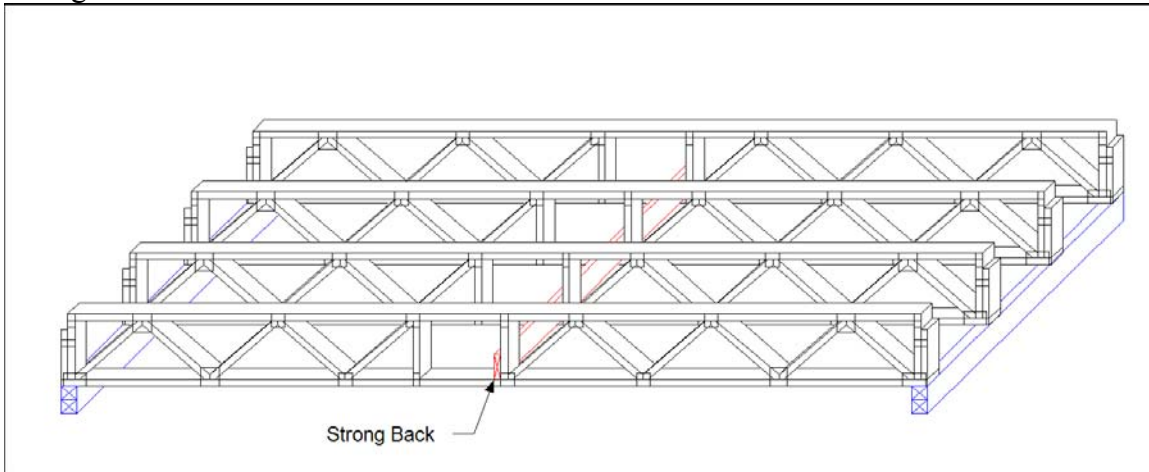

Figure 9: Strong Back installed in a floor truss system.

The maximum top chord panel length for floor trusses is 2'-6" with a 2' maximum chase opening. The following table lists maximum acceptable panel lengths for roof trusses based on the design limits of Southern Yellow Pine lumber.

<u>Member Size</u>	<u>Panel Size</u>
2 x 4 top chords	8'-2"
2 x 4 bottom chords	11'-4"
2 x 6 top chords	10'-0"
2 x 6 bottom chords	13'-0"
2 x 4 Overhang	2'-6"
2 x 6 Overhang	5'-0"

For attic trusses, the rule of thumb for the room width is limited to 22 times the depth of the bottom chord (BC). The following is a summary of some attic room widths:



Introduction to the Design of Wood Trusses
A SunCam online continuing education course

<u>Member Size</u>	<u>Room Size</u>
Attic room 2 x 6 BC	10'-1"
Attic room 2 x 8 BC	13'-3"
Attic room 2 x 10 BC	17'-0"
Attic room 2 x 12 BC	20'-7"

It is possible to go beyond these panel limits, but the truss may exhibit increased deflection and/or vibration.

Software and Design Considerations:

The modern software available for designing metal plated wood trusses is sophisticated and very powerful, but the software packages do have some limitations. The plate manufacturers usually supply software for the purpose of designing metal plated wood trusses with their proprietary plates. This is usually a mutually beneficial arrangement between the plate manufacturer and truss manufacturer since the truss manufacturer requires both truss plates and software to produce trusses efficiently.

Since most residential plans are designed using architectural units, the plate manufacturers use Feet-Inch-Sixteenths (FIS) notation for all dimensions which provides a convenient way for the truss technicians to input dimensions. An example of the notation would be 8-3-4 which when converted to architectural units would be 8'-3 1/4". That same number could also be written without dashes as 80304 in which case the last two digits would be reserved for sixteenths, the next two digits to the left for inches, and the remainder for feet. Also, since many dimensions are an integer foot increment, the plate manufacturers added the ability to input dimensions in decimal feet by adding a period either at the end or within the number. The following table includes some additional examples of the FIS notation and their conversions to architectural units:

<u>FIS</u>	<u>Architectural</u>
9	9/16"
102	1 1/8"
20615	2'-6 15/16"
8.	8'-0"
70.5	70'-6"

A key part of the software is a 3-D CAD layout package that is used to set up the walls, roof planes, ceiling features, and input the truss profiles. For a roof truss package, the truss technician will first input the exterior bearing walls and other important features that will define the roof planes such as dormer walls, chimneys, and valley lines. The next step is to define and cut the roof planes. The technician will input the pitch, heel height, top chord overhang, and bottom chord cantilever values to define the roof planes. To cut the planes, the technician defines the boundary of each roof plane by clicking on each plane or wall that borders the plane being cut. The truss technician would then focus on the ceiling features such as trays and vaults. Once the roof and ceiling planes are input into the layout program, the truss technician will place trusses on the layout beginning with the girders or with the framing at the end depending on the truss technician's preference. Refer to Figures 1& 2 for an example of a completed truss placement plan and isometric view.



Introduction to the Design of Wood Trusses
A SunCam online continuing education course

The truss technician should consider truss spacing, hip girder set backs, girder truss locations, and cost saving ideas when placing the trusses. Most roof trusses and a substantial number of floor trusses are set at 24" o.c. because that is the span limit of most commercially available sheathing products such as Plywood and Oriented Strand Board (OSB). In the case of floor trusses and attic roof trusses, however, the spacing may need to be reduced in order to maintain structural integrity. In such cases, the most common reduced spacing designs are 19.2" and 16" o.c. These spacing designs are based on dividing an 8' piece of sheathing into equal portions: $8' / 4$ truss spaces = 24" o.c., $8' / 5$ truss spaces = 19.2" o.c., and $8' / 6$ truss spaces = 16". Roof trusses may be designed at a spacing greater than 24" o.c. for agricultural and similar structures where the top chord is braced with purlins, structural insulated panels (SIPs) or other products that can span the larger distance.

The consideration of the hip girder set back varies by manufacturer and region of the country. In regions where most structures utilize a hip roof design, some manufacturers will establish a standard hip girder setback and pre-build some common jack truss setups to maintain in stock enhancing workflow efficiency. Other manufacturers establish the setback for each case based on other factors such as pitch, heel height, volume ceiling locations, and window header locations.

An experienced technician will look for ways to optimize the layout to reduce the cost of the project. When wood trusses are manufactured, they are placed on large tables in custom made jigs. Anything that can reduce the number of jig setups will reduce the cost to the manufacturer, so the technician will usually try to maximize the number identical trusses or make the trusses as similar as possible. As an example, by setting the hip girder setbacks to be the same on both ends of the house, even though the two girders may be a different span, the same jack and hip jack trusses can be used multiple times. The hip girder setback can also be adjusted to optimize the number of longer hip trusses and shorter jack trusses.

Once the trusses are placed on the layout, the profiles are then transferred to the engineering side of the software package where lumber is added to each truss and the structural analysis run. The technician will go through each truss to identify those that failed the structural analysis, require special loading, or can be cost optimized. If a truss member fails the structural analysis, the technician may upgrade the lumber to a higher grade or a larger size, change web locations, stack the member, or use scabs. Stacked members would be placed above or below existing truss members and remain in the plane of the truss. Scabbed members would be applied to the side of existing truss members usually at the time of erection.

The software usually has the ability to automatically generate loads for the girder trusses. This process produces concentrated loads based on the reactions of the supported trusses at the appropriate locations along the length of the girder. The truss technician must carefully review these loads because the reactions of the supported trusses may have changed. Some reasons for the changed loads include:

- Change of the web locations may change the length that the 20 psf load for a 24" wide (or greater) x 42" high open area above the bottom chord as previously discussed.



Introduction to the Design of Wood Trusses
A SunCam online continuing education course

- Change from a common roof truss to an attic truss may greatly increase the reactions.
- Supplemental loads such as field framing, roof top HVAC units, cupolas, steeples, etc. need to be evaluated.

Assuring that the design loads on the trusses are correct is the most important aspect of the truss technician's job. Incorrect geometry of the truss is usually caught at the time of erection and will be corrected long before the structure is inhabited. A truss with incorrect loading, however, may fit appropriately into the envelope of the structure and pass a visual inspection allowing the structure to be inhabited. A substantial structural problem may not be revealed until the first large snow or other loading event. Missed loads present a great risk to the safety of the inhabitants of the structure and the greatest liability for the truss manufacturer. Therefore the truss design staff should develop a strong understanding of the loading of trusses and employ thorough checking procedures.

An experienced technician should also have a good understanding of how the computer model is established. The truss plate manufacturers use a modified version of the ideal truss model that engineering students study in college to develop a computer model of the wood truss. The ideal truss model uses zero thickness members with all joints being pinned or hinged allowing for no moment transfer across the joints and requires all loads to be applied at the joints. The zero thickness members for the wood truss model are retained. Some members, including webs, are designed with pinned ends. Truss chord members are usually designed with some measure of fixity at the joints allowing for some moment transfer across joints. Also, the wood truss model allows loads to be applied almost anywhere including at or between joints on the truss.

The computer model is generally an accurate representation of a true wood truss, and the model lines usually follow along the wood members. However, there are occasions where the model deviates from the wood truss members displayed on the computer screen. Figure 10, for example, shows a mono truss with the model bearing location in a different location than the actual bearing which would result in inaccurate calculation of the shear forces in the bottom chord extension. In small trusses this would not be an issue, but larger trusses may experience a shear failure. In this example, the software package combines adjacent joints, which explains why the model bearing is shown at the center of the end vertical rather than over the actual bearing.

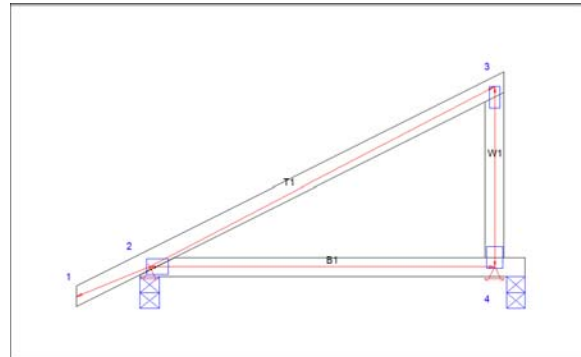

Figure 10: Truss Computer Model



Introduction to the Design of Wood Trusses
A SunCam online continuing education course

Optimization and Manufacturing Considerations:

An important aspect to the truss technician's job is cost optimization because in some situations a cost effective job will enhance the truss manufacturer's profitability. The benefits of cost optimization will vary depending on the limitations of the equipment in the truss manufacturer's facility.

There are three main types of saws in modern truss facilities: Radial arm, multi-bladed, and robotic arm. The radial arm saw is a manually operated saw usually used for cuts that the automated saws can not cut. Figure 11 is a schematic of a radial arm saw. The saw is mounted on an arm that may rotate through as much as 160 degrees or more of horizontal rotation.

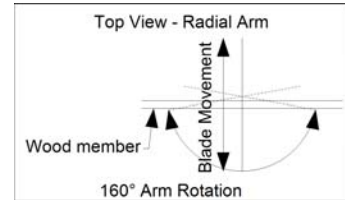

Figure 11: Radial Arm Saw

There are various designs of the multi-bladed saw concept, but it generally has 2 or 3 saw blades at each end of the saw. The multi bladed saw is computerized and automated to rotate each blade through as much as 80 degrees or more of vertical rotation. Figure 12 is a schematic of a multi-bladed saw. One end of the saw is movable for length adjustments. At each end one saw blade will rotate clockwise and the other rotate counter-clockwise away from vertical. If there is a third blade at either end, it is usually a larger blade for cutting long shallow cuts on larger wood members. The lumber is fed through the saw on a conveyor belt and the saw blades on either end are in a line parallel to the direction of movement. The advantage of this type of saw is the ability to quickly cut multiple identical pieces.

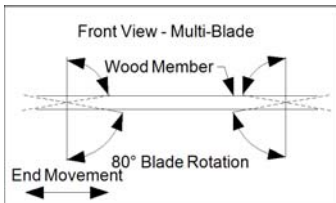

Figure 12: Multi-Bladed Saw

The robotic arm saw is also computerized and automated, but it has only one blade. Figure 13 is a schematic view of a robotic arm saw. The blade is mounted to an arm that moves up and down and rotates through 360 degrees of horizontal rotation with the center of rotation lining up with the center of the blade. The key

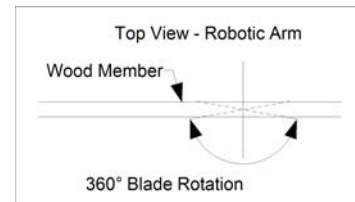

Figure 13: Robotic Arm Saw

advantage to this type of saw is lumber optimization. The robotic arm saw would be accompanied by length optimization software. This saw uses less lumber because it can quickly combine various cuts and lengths to maximize use of each board.

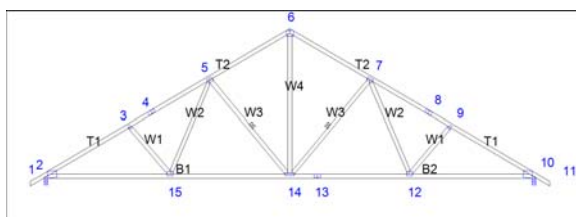

Figure 14: Symmetric Common Truss

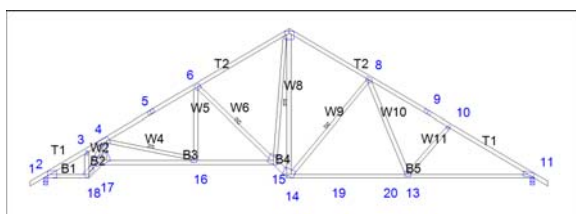

Figure 15: Tray Truss



Introduction to the Design of Wood Trusses
 A SunCam online continuing education course

saw facility, the truss technician will want to make as many cuts the same across several trusses. This can be accomplished through partial truss symmetry and using the same web configuration across several truss designs. The trusses in Figures 14 and 15 show two similar trusses in a run demonstrating how common webs can be used across several truss designs. Figure 14 is a symmetric common truss and Figure 15 is a similar truss with a tray ceiling. The three diagonal webs on the left (W1, W2, and W3) of the common truss would match the three webs on the right side of both the common and tray truss (W11, W10, and W9 respectively). The center vertical (W4), also known as a kingpost, along with the top chord members (T1, T2) would match on both trusses. Making these webs the same across several trusses increases the efficiency and reduces cost of a truss facility with a multiple blade saw.

Another technique that many technicians use to optimize the lumber usage in a multi-blade facility is rotating certain webs to come up with a more ideal lumber length. Since lumber is normally supplied to the truss manufacturer in integer lengths, the ideal length of a member would be as close as possible to the integer number length. Some truss manufactures, however, choose to pick lumber one integer size longer at certain inch increment to allow the saws extra working space. As an example, a truss manufacturer may decide that any piece of lumber over the 11" increment would go to the next integer size. In this example, the manufacturer would choose boards as follows:

<u>Final Member Length</u>	<u>Picked Lumber Size from Inventory</u>
5'-11"	6'-0"
5'-11 1/6"	7'-0"
6'-2"	7'-0"
6'-10 1/2"	7'-0"
6'-11 1/4"	8'-0"

If the W1 web member in Figure 14 is 4'-6" long and the W2 web member is 7'-2" long, this manufacture would pick a 5' long board for W1 and an 8' long board for W2. If the truss technician shifted Joint 15 to the right, the new web member lengths would be 4'-9" for W1 and 6'-11" for W2. The manufacturer would then pick a 5' long board for W1 and a 7' long board for W2. One linear foot of lumber per symmetric end of each truss would be saved as a result of this optimization.



Introduction to the Design of Wood Trusses
 A SunCam online continuing education course

Optimization of trusses can also be achieved by removing redundant web members. The best truss designs use nicely shaped triangles, and webs too close together reduce triangulation effectiveness. Webs added to the truss beyond the optimal range add cost to the truss without structural benefit. Ideally trusses should have triangles from one end to the other; exceptions for short trusses, attic frames, and gables. The trusses in Figures 16 and 17 display this principle of redundant members. Figure 16 shows a hip tray truss with redundant members where a vertical member is present at every top and bottom chord pitch break. Figure 17 shows a more optimized truss with two fewer web members. Fewer members on the optimized truss required lumber upgrades, and the deflection of the two trusses was nearly identical. Removal of redundant members benefits both multi-bladed and robotic arm truss facilities because of the linear footage reduction.

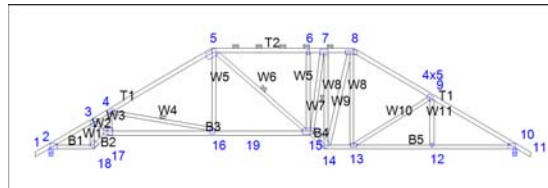

Figure 16: Truss with Redundant Webs

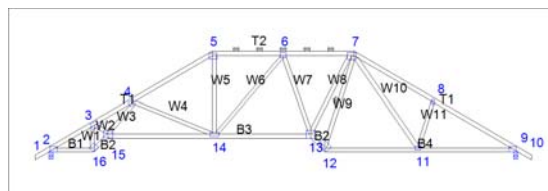

Figure 17: Truss with Optimized Webs

Figure 16 shows a hip tray truss with redundant members where a vertical member is present at every top and bottom chord pitch break. Figure 17 shows a more optimized truss with two fewer web members. Fewer members on the optimized truss required lumber upgrades, and the deflection of the two trusses was nearly identical. Removal of redundant members benefits both multi-bladed and robotic arm truss facilities because of the linear footage reduction.

The truss technician should also consider the chord splice locations for an optimized truss design. The type of equipment at the truss facility influences the best choices regarding the splice location. In a multi-bladed truss facility, it is usually best to make the splice locations the same on as many trusses as possible while weighing the consequence of the length picking. In the example in Figures 14 and 15, the top chord splices are placed such that top chord members T1 & T2 are the same on both sides of the truss and on both trusses. Figures 18 and 19 show a truss with a 22' span with different splice locations. In Figure 18 both bottom chord members are identical and would require the use 24' of lumber for the two members if the manufacturer picks lumber at a value less than the integer lumber lengths.

Figure 18: Centered Bottom Chord Splice. A technical drawing of a truss with a centered bottom chord splice. The bottom chord is labeled with nodes 1 through 11. The splice is located at the center of the bottom chord.

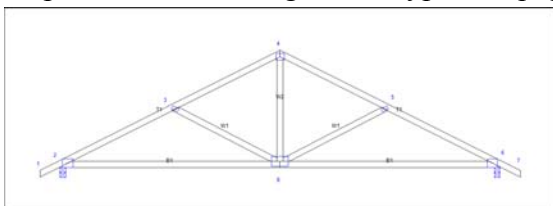

Figure 18: Centered Bottom Chord Splice

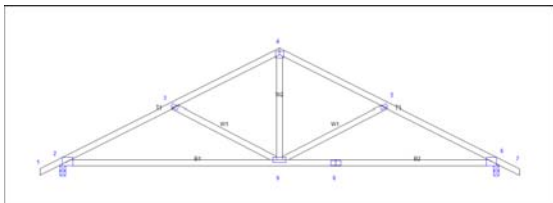

Figure 19: Off-Center Bottom Chord Splice

If the splice were moved to 13'-11" from the left end like in Figure 19, one 14' board and one 9' board would be chosen saving one linear foot of lumber. The location of the splice may also affect the total truss plate area. One large plate would be used to plate the center joint in Figure 18 and two smaller plates in Figure 19 which may actually reduce total plate area.

For robotic arm truss facilities, the splice locations are dependant on the facility's preference on the placement of splices. Most facilities use some combination of splicing



Introduction to the Design of Wood Trusses
A SunCam online continuing education course

at the joints or away from the joints that would depend on the pricing model utilized at the facility.

Another consideration regards the placement of the splice in proximity to but not directly centered on the webs. Figure 20 shows the same truss as in Figures 18 and 19, but with the splice located in an undesirable location possibly caused by automatic splicing routines. This splice-web combination uses more steel plate area than either the centered splice truss in Figure 18 or the mid panel splice in Figure 19 and unnecessarily adds cost to the truss. Structurally, the truss plate has sufficient coverage to support the design loads. However, the appearance is undesirable and there may be problems assembling the joints, so a substantially off-center splice plate design should be avoided.

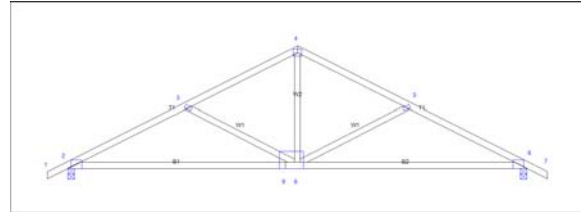

Figure 20: Undesirable Splice Location

Conclusion:

Metal Plate Wood Trusses have become a popular means for framing residential and light commercial structures because they provide greater flexible for the building designer, a faster production schedule for the contractor, and less waste for the environmentally and economically conscience owner. The design limits and practical concerns regarding the use of wood trusses as discussed in this document must also be weighed against the significant advantages over conventional stick build construction.

References and Notes:

- All photos displayed were provided by Gary Sweatt, PE who provided them as resource saying “Anything I can do to help our industry prevent problems is my goal.”
- The truss profiles, truss placement plan, and isometric image presented in this document were produced using Mitek 20/20™ suite of software developed by Mitek Industries Incorporated of Chesterfield, MO.
- I would like to thank the management and employees of Builders FirstSource who have been my mentors and friends through the years.
- National Design Standard for Metal Plate Connected Wood Truss Construction, ANSI/TPI 1-2002, published by Truss Plate Institute (TPI), Madison WI, 2002.
- Building Component Safety Information, BCSI 2008, a joint publication of Truss Plate Institute (TPI) of Madison, WI, and the Structural Building Components Association (SBCA) previously known as Wood Truss Council Association (WTCA) of Madison WI, 2008.
- American Forest and Paper Association, AF&PA, National Design Specification, NDS-2005 & supplement, published by American Wood Council of Washington, D.C., 2005.
- International Residential Code 2006 for One- and Two-Family Dwellings (IRC2006), published by the International Code Council of Washington, D.C., 2006.