



Electrical Power: Part I
A SunCam Online Continuing Education Course

Electrical Power

Part I: Generation

Part II: Distribution Systems

Part III: Transformers

Part IV: Transmission Lines

Part V: The National Electrical Safety Code (NESC)

Fundamentals / Plants: Fossil, Nuclear, Hydroelectric, Cogeneration / Prime Movers /
Generators: AC & DC / Parallel Operation / Power Quality

by

John A Camara, BS, MS, PE, TF



Electrical Power: Part I
A SunCam Online Continuing Education Course

Nomenclature¹

A	ABCD parameter	-
a	phase	-
A	area	m ²
B	ABCD parameter	-
B	magnetic flux density	T
B	magnetic flux density	T
B	susceptance	S, Ω^{-1} , or mho
b	phase	-
c	speed of light	m/s
C	capacitance	F
C	ABCD parameter	-
c	phase	-
D	ABCD parameter	-
D	distance	m
E	electric field strength	V/m
E	energy	J
f	frequency	Hz, s ⁻¹ , cycles/s
f_{droop}	frequency droop	Hz/kW
G	conductance	S, Ω^{-1} , or mho
GMD	geometric mean distance	m
GMR	geometric mean radius	m
h	specific enthalpy	kJ/kg
I	effective or DC current	A
I	rms phasor current	A

¹ Not all the nomenclature, symbols, or subscripts may be used in this course—but they are related, and may be found when reviewing the references listed for further information. Further, all the nomenclature, symbols, or subscripts will be found in all “Parts” of this complete course. For guidance on nomenclature, symbols, and electrical graphics: IEEE 280-2021. IEEE Standard Letter Symbols for Quantities Used in Electrical Science and Electrical Engineering. New York: IEEE; and IEEE 315-1975. Graphic Symbols for Electrical and Electronics Diagrams. New York: IEEE, approved 1975, reaffirmed 1993.



Electrical Power: Part I
A SunCam Online Continuing Education Course

K	correction factor	-
K	skin effect ratio	-
l	length	m
L	inductance	H
m	mass	kg
M	mutual inductance	H
n	Steinmetz exponent	-
N	number of turns	-
n_s	synchronous speed	r/min or min^{-1}
p	pressure	Pa
P	number of poles	-
P	power	W
pf	power factor	-
pu	per unit	-
Q	heat	J
r	radius	m
R	resistance	Ω
s	specific entropy	$\text{kJ/kg}\times\text{K}$
S	apparent power	kVA
SWR	standing wave ratio	-
T	temperature	$^{\circ}\text{C}$ or K
v	wind velocity	km/hr
V	effective or DC voltage	V
v	velocity (speed)	m/s
V	rms phasor voltage	V
V_{droop}	voltage droop	V/kVAR
VR	voltage regulation	-
W	work	kJ
X	reactance	Ω
x	variable	-
Y	admittance	S, Ω^{-1} , or mho



Electrical Power: Part I
A SunCam Online Continuing Education Course

y	admittance per unit length	S/m, 1/Ω×m Ω ⁻¹ , or mho/m [\overline{U} /m]
Z	impedance	Ω
z	impedance per unit length	Ω/m
Z ₀	characteristic impedance	Ω

Symbols

α	turns ratio	-
α	attenuation constant	Np/m
α	thermal coefficient of resistance	1/°C
β	phase constant	rad/m
γ	propagation constant	rad/m
Γ	reflection coefficient	-
δ	skin depth	m
Δ	change, final minus initial	-
ε	permittivity	F/m
ε ₀	free-space permittivity	8.854 × 10 ⁻¹² F/m
ε _r	relative permittivity	-
η	efficiency	-
θ	phase angle	rad
κ	coupling coefficient	-
μ	permeability	H/m
μ ₀	free-space permeability	1.2566 × 10 ⁻⁶ H/m
μ _r	relative permeability	-
ξ	ratio of radii	-
ρ	resistivity	W·m
σ	conductivity	S/m
ω	armature angular speed	rad/s



Electrical Power: Part I
A SunCam Online Continuing Education Course

Subscripts

ϕ	phase
0	zero sequence
0	characteristic
0	free space (vacuum)
0,o	initial (zero value)
1	positive sequence
1	primary
2	negative sequence
2	secondary
ab	a to b
AC	alternating current
avg	average
bc	b to c
c	controls or critical
c	core
C	capacitor
ca	c to a
Cu	copper
d	direct
DC	direct current
e	eddy current
e	equivalent
eff	effective
ext	external
f	final / frequency
fl	full load
g	generator
h	hysteresis
int	internal
l	line
l	line



Electrical Power: Part I
A SunCam Online Continuing Education Course

l	per unit length
L	inductor
ll	line-to-line
m	motor
m	maximum
m	mutual
max	maximum
n	neutral
nl	no load
O	origin
oc	open circuit
p	phase
p	primary
ps	primary to secondary
pu	per unit
q	quadrature
R	receiving end
R	resistance
s	synchronous
s	secondary
S	sending end
sc	short circuit
sys	system
t	terminal
w	wave



Electrical Power: Part I
A SunCam Online Continuing Education Course

TABLE OF CONTENTS

Nomenclature.....2

Symbols4

Subscripts.....5

List of Figures8

List of Examples8

List of Equations.....8

INTRODUCTION9

FOSSIL FUEL PLANTS.....10

NUCLEAR POWER PLANTS.....13

HYDROELECTRIC POWER15

COGENERATION PLANTS16

PRIME MOVERS16

ALTERNATING CURRENT GENERATORS18

PARALLEL OPERATION22

DIRECT CURRENT GENERATORS25

POWER QUALITY29

REFERENCES32

Appendix A: Equivalent Units Of Derived And Common SI Units33

Appendix B: Physical Constants.....33

Appendix C: Fundamental Constants.....36

Appendix D: Mathematical Constants38

Appendix E: The Greek Alphabet.....38

Appendix F: Coordinate Systems & Related Operations39



Electrical Power: Part I
A SunCam Online Continuing Education Course

List of Figures

FIGURE 1: BASIC RANKINE CYCLE10
FIGURE 2: BASIC REHEAT CYCLE11
FIGURE 3: BASIC REGENERATION CYCLE12
FIGURE 4: PRESSURIZED WATER REACTOR14
FIGURE 5: BOILING WATER REACTOR15
FIGURE 6: STEAM TURBINE TYPES17
FIGURE 7: ROTOR CONSTRUCTION AND AC GENERATOR OUTPUT19
FIGURE 8: AC OUTPUT GENERATION21
FIGURE 9: REAL LOAD SHARING23
FIGURE 10: REACTIVE LOAD SHARING24
FIGURE 11: COMMUTATOR ACTION26
FIGURE 12: DC MACHINE WINDINGS27
FIGURE 13: DC GENERATOR ARMATURE FLUX28
FIGURE 14: DC MACHINE COMMUTATING POLES AND COMPENSATING WINDINGS29
FIGURE 15: POWER DISTURBANCES30

List of Examples

EXAMPLE 121
EXAMPLE 221
EXAMPLE 325

List of Equations

EQUATION 1: EINSTEIN’S EQUATION13
EQUATION 2: FUEL UTILIZATION16
EQUATION 3: POWER-TO-HEAT RATIO16
EQUATION 4: TURBINE EFFICIENCY18
EQUATION 5: SYNCHRONOUS SPEED20
EQUATION 6: ELECTRICAL DEGREES20
EQUATION 7: LOAD FREQUENCY23
EQUATION 8: POSITIVE FREQUENCY DROOP23
EQUATION 9: VOLTAGE DROOP24
EQUATION 10: POSITIVE VOLTAGE DROOP24



Electrical Power: Part I
A SunCam Online Continuing Education Course

INTRODUCTION

Although this is a five part course, each individual part is meant to be stand-alone should one be interested in that topic. The overall purpose of the course is to provide an overview of electric power from generation, through the various distribution systems, including the vital transformer links that change the voltage from the high voltage required for minimum losses during transmission to medium- and low-voltage for the end-users. Additionally, the transmission lines connecting the system are covered. And, finally, the rule from the National Electric Safety Code[®] (NESC[®]) that govern it all completes the overview.

Part I, Generation, the more common type of plants producing the power. The basics of alternating current and direct current generators is explained include the principles of parallel operation. Finally, energy management and power quality are covered.

Part II, Distribution Systems, covers the classification of such systems, how the common neutral is utilized, overhead and underground distribution, along with fault analysis methods.

Part III, Transformers, informs on power transformers, their ratings, voltage regulation, testing methods and parameters used to analyze both transformers and transmission lines.

Part IV, Transmission Lines, discusses the electrical parameters of such line: resistance, inductance, and capacitance. Important effects such as the skin effect and reflection are explained. This part completes with an explanation of models for each type of transmission line: short, medium, and long.

Part V, The National Electrical Safety Code, covers organization of the code and some of the multitude of requirements for the transmission of electrical power.

The information is primarily from the author's books, Refs. [A] and [B] with the NESC information from the Handbook covering the code, Ref. [C]. The coverage of the NESC does not included end-users buildings—this is covered by the NEC, Ref. [D]. Information useful in many aspects of electric engineering may be found in the appendices.



Electrical Power: Part I
A SunCam Online Continuing Education Course

FOSSIL FUEL PLANTS

The electric utility industry is one of the largest users of fossil fuels. Fossil fuels are those composed of hydrocarbons, such as petroleum, coal, and natural gas. Typical combustion of the fuel produces high-pressure, high-temperature steam.² The pressures range from 16.5–24 MPa (2400–3500 psig). A common steam temperature is 540°C (1000°F). The basic thermodynamic cycle is the Rankine cycle shown in Fig. 1, along with typical plant components. Turbines used to drive the electrical generators spin at 3600 rpm. The efficiency of the cycle is proportional to the temperature difference between the temperature at the *source*, that is, the steam generator, and the *sink*, that is, the cooling medium of the condenser.

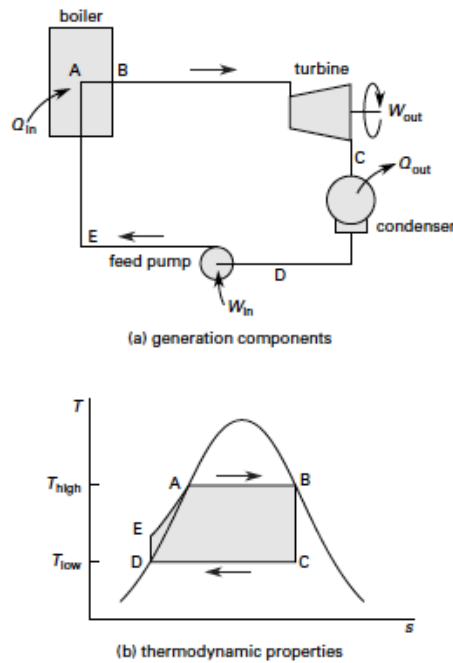

Figure 1: Basic Rankine Cycle

² Steam is the most common substance used, but the principles discussed are applicable to vapor cycles in general. See Ref. [E].



Electrical Power: Part I
A SunCam Online Continuing Education Course

Efficiency improves when the source temperature is raised. Additionally, turbine blade wear is reduced as the moisture content in the expanding steam is reduced. Both are accomplished by adding heat to the steam beyond that required to maintain the steam in the vapor phase, that is, raising the steam temperature above the saturation temperature for the associated pressure, a process known as *superheating*. The maximum practical metallurgical limit on superheating is approximately 625°C (1150°F). In some situations, moisture still forms in the low-pressure turbine stages. This problem is overcome by reheating the steam after partial isentropic expansion in the turbine, then allowing the remaining expansion to take place, a process *reheating*. A generation plant operating with these modifications is said to use the *reheat cycle*. The steam flow through the plant and the resulting thermodynamic cycle are shown in Fig. 2.

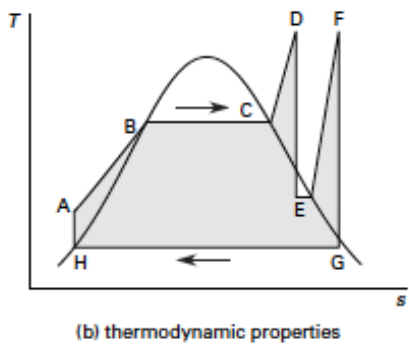
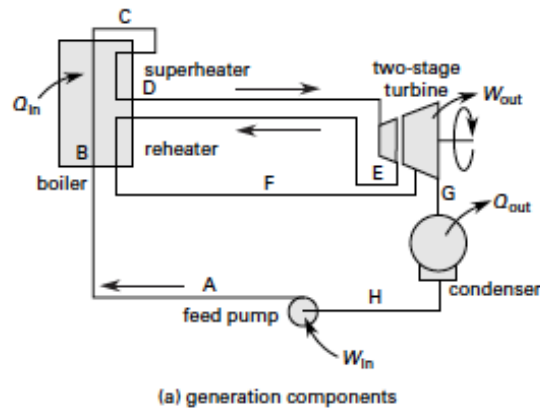
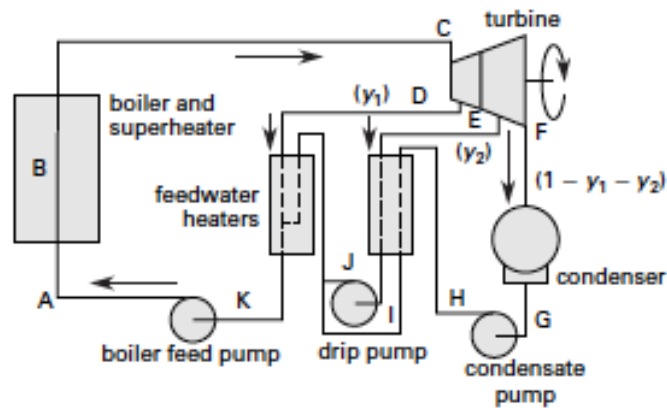

Figure 2: Basic Reheat Cycle



Electrical Power: Part I
A SunCam Online Continuing Education Course

Efficiency can be further increased by minimizing the irreversibilities in the Rankine cycle associated with heating the compressed water to saturation by a finite temperature difference occurring between points E and A in Fig. 1 and points A and B in Fig. 2. This is accomplished by using heat sources elsewhere in the cycle that have temperatures slightly above that of the compressed liquid. The process is known as regeneration and is illustrated in Fig. 3. Superheating, reheating, and regeneration are all used to raise the mean effective temperature at which heat is added. Superheating raises the temperature prior to turbine input, reheating raises the temperature prior to low-pressure turbine input, and regeneration raises the temperature of the compressed liquid returning to the boiler, thus minimizing the heat addition required in the boiler.



(a) generation components

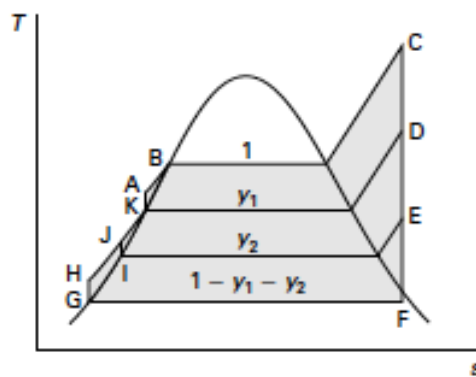

(b) thermodynamic properties

Figure 3: Basic Regeneration Cycle



Electrical Power: Part I
A SunCam Online Continuing Education Course

Fossil fuels are broadly categorized into solid, liquid, and gaseous types. They may be further classified as natural, manufactured, or by-product. Coal is arguably the most important fossil fuel, because it is widely used and has well-known reserves. The most commonly used types of coal are anthracite, bituminous, subbituminous, and lignite. Environmental concerns involving the burning of coal include the emission of nitrogen oxides, sulfur oxides, particulate matter, and ash. The nitrogen oxides are minimized by control of the fuel-air mixture during combustion and postcombustion reduction using chemical reagents. Sulfur oxides are minimized using a variety of flue-gas desulfurization (FGD) systems. Particulate matter is minimized using electrostatic precipitators. Ash is controlled by a variety of means including coal selection, combustion techniques, and various filtration means. Residual fuel oil is used as the source fuel for combustion in electric generating plants. Residual oil is what remains after lighter hydrocarbons, such as gasoline, have been removed from crude oil. The plant operating principles are similar to those for coal, with the significant difference being the design of the boiler. Environmental concerns include gaseous emissions, removal of oil from environmentally sensitive areas, and oil transportation safety.

Natural gas is highly valuable for various chemical and space-heating uses. Consequently, its use in large-scale electric power plants is minimal.³

NUCLEAR POWER PLANTS

The energy process in nuclear power plants is fundamentally different from that of fossil fuel plants. While fossil fuels are burned or undergo combustion, nuclear fuels, normally uranium, change form and in the process release energy. The amount of energy released is given by Einstein's equation.

Equation 1: Einstein's Equation

$$E = mc^2$$

³ This too, is changing as various concerns come into play. The next section illuminates one of the better environmental options.



Electrical Power: Part I
A SunCam Online Continuing Education Course

During *fission* a uranium atom is split, by the absorption of a neutron, into two or more elements of lower atomic mass, plus additional neutrons. When the total combined mass of the products is compared to the mass of the reactants, a *mass defect* of approximately 0.215 amu is noted. Substituting this mass defect into Eq. 1 results in an energy of approximately 200 MeV / fission (3.2×10^{-11} W·s/fission). *Fusion* combines lighter elements to create an element of higher mass, but it also results in a mass defect and subsequent release of energy. All current commercial electric generation plants are based on the fission process.

Nuclear power plants operate on the same thermodynamic cycles as fossil fuel plants. Pressurized water reactors (PWR) are constructed of two loops, a primary and a secondary, as shown in Fig. 4. The primary system operates in the range of 13.8–17.3 MPa (2000–2500 psia). The temperature of the primary, at approximately 300°C (572°F), is well below the saturation temperature for this pressure range, to prevent boiling and other adverse effects. As a result, the steam side operates at lower temperatures and pressures than in a fossil fuel plant—approximately 8.4 MPa (1230 psia), correlating with the 300°C (572°F) operating temperature on the primary side.

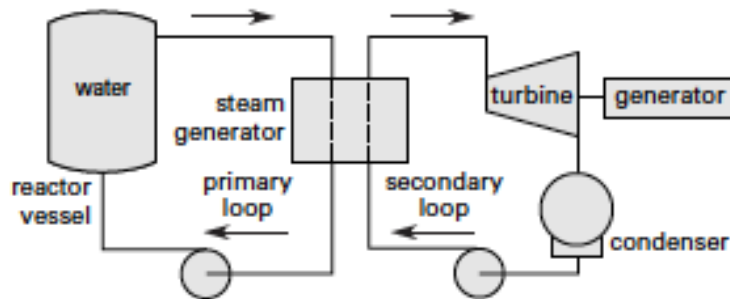

Figure 4: Pressurized Water Reactor

A boiling water reactor (BWR) generates steam directly in the core. Such a reactor operates at lower pressures than the typical PWR, usually 6.9 MPa (1000 psia). The steam is passed through various separators and dryers to minimize the moisture content prior to entering the turbine.



Electrical Power: Part I
A SunCam Online Continuing Education Course

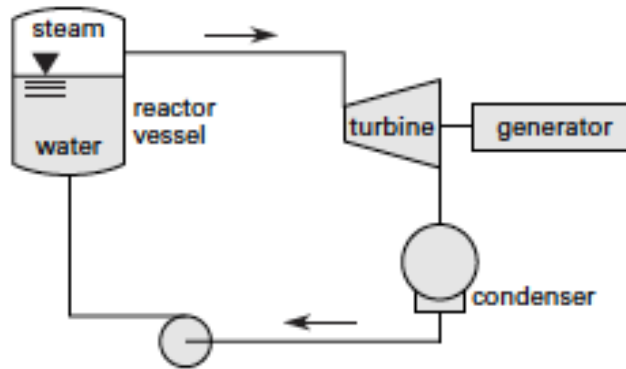

Figure 5: Boiling Water Reactor

Additional fundamental differences in nuclear power plants compared to fossil fuel plants include a significantly higher thermal energy density (0.80 kW/l versus 0.20 kW/l), heat generation after shutdown caused by radioactive decay, and minimal environmental emissions. Fossil fuel plants emit carbon dioxide (CO₂), nitrogen dioxide (NO₂), sulfur trioxide (SO₃), particulate matter and, in the case of coal, ash. Nuclear power plants emit small quantities of gaseous products and, when no longer capable of generating power, solid radioactive waste products from the fuel. (See Ref. [F].)⁴

HYDROELECTRIC POWER

The flow of water from higher elevations to lower elevations changes potential energy to kinetic energy that can be used to drive electric generators directly without the depletion of any fuel. While this eliminates the plant components that deliver heated steam to the turbine and condensed water back to the generator, it does require a source of water large enough to generate a steady output and the ability to control that source. Environmental considerations include the multiple effects of creating large reservoirs of water. Additionally, the multiple uses of the water—for navigation, irrigation, recreation, and flood control—compete with the production of power and significantly impact costs.

⁴ The waste products could be reduced to 10% of their current amount via recycling—which is done by several countries and the military now. Further, fissioning 1 g of U-235 per day produces as much energy as 600 Barrels of oil or 3 Tonnes of coal—all with essentially no CO₂ emissions.



Electrical Power: Part I
A SunCam Online Continuing Education Course

COGENERATION PLANTS

Cogeneration is the simultaneous on-site generation of electric energy and process steam or heat from the same plant. All power cycles discard a large portion of incoming energy as heat energy. Typical plant efficiencies are on the order of 30%. The other 70% of the energy is rejected to the environment as heat. If this heat is recovered and used for *space heating*, also called *district heating*, or cooling (using an *absorption system*), the process is called a *cogeneration cycle*. If the recovered heat instead vaporizes water in a steam power cycle, the process is called a *combined cycle*. In cogeneration, the recovered heat is used as heat and not converted into mechanical or electrical energy. Two terms are used to measure this recovered energy, neither of which is the same as thermal efficiency. The *fuel utilization* given in Eq. 2 is the ratio of useful energy to energy input. The *power-to-heat ratio* relates turbine work to the energy recovered, Eq. 3.

Equation 2: Fuel Utilization

$$\text{fuel utilization} = \frac{W_{\text{turbine}} + Q_{\text{recovered}}}{Q_{\text{in}}}$$

Equation 3: Power-to-Heat Ratio

$$\text{power-to-heat ratio} = \frac{W_{\text{turbine}}}{Q_{\text{recovered}}}$$

PRIME MOVERS

Steam prime movers are of two types, reciprocating and turbine. *Reciprocating prime movers* are used primarily in low-speed (100–400 rpm), high-efficiency applications requiring high starting torque. As such, they are used for auxiliary applications throughout a power plant. *Steam turbines* dominate as the mover of choice for electric power generation. They are variable-speed (1800–25,000 rpm), relatively efficient (85% in large machines), require no internal lubrication, and operate at steam pressures ranging from 34.5 MPa (5000 psig) and 565°C (1050°F) to 1.7 MPa (0.5 in Hg absolute). Most important for electric generation, they can be built in capacities over 1,000,000 kW—more than any other prime mover.



Electrical Power: Part I
A SunCam Online Continuing Education Course

Steam turbines are a series of nozzles in which heat energy is changed to kinetic energy that is then transferred to a rotating wheel or drum and ultimately to an output shaft. *Impulse turbines* use stationary nozzles that drop the pressure with the kinetic energy absorbed in rotating blades operating at approximately constant pressure. *Reaction turbines* drop pressure in both the stationary and rotating portions. The steam turbine types and their associated pressure-velocity diagrams are shown in Fig. 6.

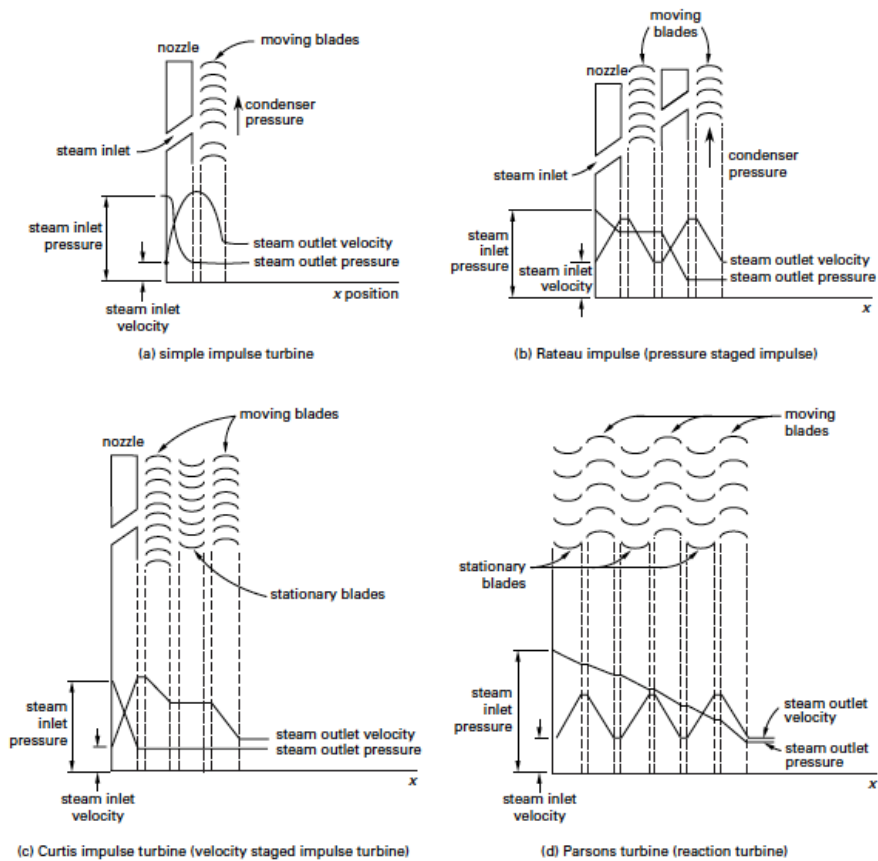

Figure 6: Steam Turbine Types

All large turbines use multiple stages to improve efficiency. Reaction turbines generally have more stages than impulse designs. A large turbine's first stage is an impulse stage because no pressure drop occurs across the moving blades. This allows for partial-arc admission of the steam. To



Electrical Power: Part I
A SunCam Online Continuing Education Course

maximize efficiency, the simple impulse turbine (single row) is the first stage, also called the *control stage*, on heavily loaded reheat turbines. The two-row Rateau impulse turbine is the control stage on small and medium-sized nonreheat turbines, in order to maintain efficiency over a wider range of operating loads. Marine turbines and mechanical drives operating at high numbers of revolutions per minute use singlerow impulse first stages in the forward directions but use a single-stage Curtis in the reverse direction to provide the required torque while minimizing windage loss in the forward direction. A Curtis stage absorbs approximately four times the energy of an impulse stage and eight times the energy of a reaction stage.

Losses in a steam turbine include clearance leakage, nozzle leakage, rotation or windage, carryover, leaving, partial arc, supersaturation, and moisture loss. The overall efficiency of a turbine is⁵

Equation 4: Turbine Efficiency

$$\eta_{\text{turbine}} = \frac{W_{\text{real}}}{W_{\text{ideal}}} = \frac{h_{\text{in}} - h_{\text{condenser}}}{h_{\text{in}} - h_{\text{out,ideal}}}$$

ALTERNATING CURRENT GENERATORS⁶

A conductor moving relative to a magnetic field experiences an induced electromotive force or voltage in accordance with Faraday's law. This is called *generator action*. The conductor in which the electromotive force is induced is called the *armature*. For alternating current generators, the armature is physically located on the *stator*, that is, the stationary portion of the generator. The *field* produces the magnetic flux that reacts with the armature. For alternating current generators, the field is located on the *rotor*, that is, the rotating portion of the generator, and is supplied by a direct current that maintains the electromagnetic pole strength, and thus the output voltage, at the desired value. This arrangement—field on the rotor, armature on the stator—is used primarily because the field current is smaller, easing design requirements for the electric connection, which is commonly made through slip rings and brushes or via brushless exciters. This allows the high-

⁵ The ideal outlet enthalpy is determined assuming a constant entropy from the inlet pressure of the turbine to the condenser pressure, that is, a straight line on the Mollier diagram. For those interested, Steam Tables are in Ref. [E].

⁶ Although an older text, Ref. [G] is one of the best books I've encountered regarding generator and motor theory.



Electrical Power: Part I
A SunCam Online Continuing Education Course

current armature output connections to be made on the stationary portion of the generator. The rotors are either *salient pole* or *cylindrical* as shown in Fig. 7. The use of salient pole rotors is mechanically restricted to low rpm applications (approximately 300 rpm). The generation of an AC output voltage using a permanent magnet field is shown in Fig. 8.

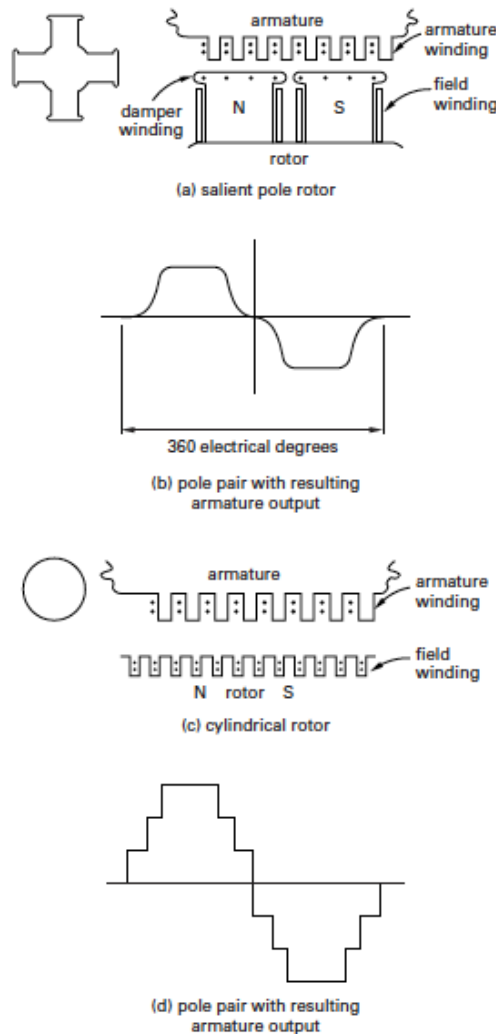

Figure 7: Rotor Construction and AC Generator Output



Electrical Power: Part I
A SunCam Online Continuing Education Course

The speed of rotation of the magnetic field in a synchronous machine is called the synchronous speed. Because two poles must pass a given point on the armature in order to complete one cycle (360 electrical degrees), the synchronous speed is

Equation 5: Synchronous Speed

$$n_s = \frac{120f}{P}$$

The term n_s is the synchronous speed in revolutions per minute, f is frequency in Hertz, and P is the number of poles.⁷ The mechanical distance around the periphery of an electrical machine is often measured in electrical degrees, with 360° the distance between a pole pair. Because one cycle of a sine wave is 360°, the mechanical and electrical degrees are related by Eq. 6.

Equation 6: Electrical Degrees

$$\text{mechanical degrees} = \frac{\text{electrical degrees}}{\text{number of pole pairs}}$$

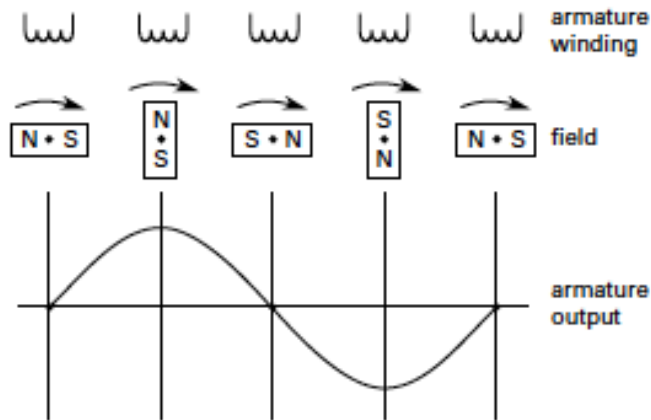

⁷ The magnetic field is moving on the armature but the armature itself is stationary. Also, a pole is either a single north or a single south. This formula is sometimes written for pole pairs, in which case the factor of 120 becomes 60.



Electrical Power: Part I
A SunCam Online Continuing Education Course

Figure 8: AC Output Generation

Losses in an AC electrical generator include *windage* and *friction*, *core*, *armature copper*, *field copper*, and *stray* or *load loss*.

Example 1

At what speed does the rotor of a four-pole AC generator turn?

Solution

The rotor in an AC generator contains the field, which rotates at synchronous speed. Because the frequency was not stated, assume 60 Hz. Substitute into Eq. 5.

$$\begin{aligned}n_s &= \frac{120f}{P} = \frac{(120)(60 \text{ Hz})}{4} \\ &= 1800 \text{ rpm}\end{aligned}$$

Example 2

What is the mechanical spacing, in degrees, between the poles of a 12-pole AC generator?

Solution

The mechanical spacing is the electrical degrees divided by the number of pole pairs.



Electrical Power: Part I
A SunCam Online Continuing Education Course

$$\begin{aligned}\text{mechanical degrees} &= \frac{\text{electrical degrees}}{\text{number of pole pairs}} \\ &= \frac{360^\circ}{6 \text{ pole pairs}} \\ &= 60^\circ\end{aligned}$$

Refer to Fig. 8 for background. Recall, such items as “poles”, “pole pairs”, and “revolutions” are not units, per se.

PARALLEL OPERATION

Generators are operated in parallel for myriad reasons, including shifting of the load to shut down a generator for maintenance, to increase the capacity available, and so on. Prior to paralleling two synchronous generators, the following conditions must be met.

- The phase sequence must be identical. The phase sequence is the order in which the phase voltages successively reach their maximum positive values. The phase sequence, normally a-b-c, is determined during construction and does not routinely require verification.
- Frequency must be matched. That is, the rotation speeds are matched. This minimizes current surges caused by the shifting of real load when the oncoming generator is connected.⁸
- Voltages must be matched. This minimizes current surges caused by the shifting of reactive load when the oncoming generator is connected.

The division of real load among generators operating in parallel is determined by the speed of the generators and the characteristics of the prime mover speed governing system as shown in Fig. 9. The slope of the *speed characteristic line*, also called the generator or frequency droop (f_{droop}), is determined by the speed governing system and is constant. The total load is also constant,

⁸ Actually, the on-coming generator should have its frequency slightly above the generator that is already on line. This ensures the on-coming generator “picks up” load. That is, it avoids being powered by the other generator by becoming a motor—which would happen if its frequency was slightly less than that of the generator already on line.



Electrical Power: Part I
A SunCam Online Continuing Education Course

assuming no loads are started or secured. If the generator's speed is manually changed, that is, if the no-load frequency is adjusted, the associated characteristic line moves up or down and the load is shifted to or from the generator. The resulting frequency of the system (f_{sys}) thus rises or falls as well. If a load is added to or removed from the system without a change in the generator's no-load frequency, the additional load results in a drop in the system frequency determined by Eq. 7.

Equation 7: Load Frequency

$$P = \frac{f_{sys} - f_{nl}}{f_{droop}}$$

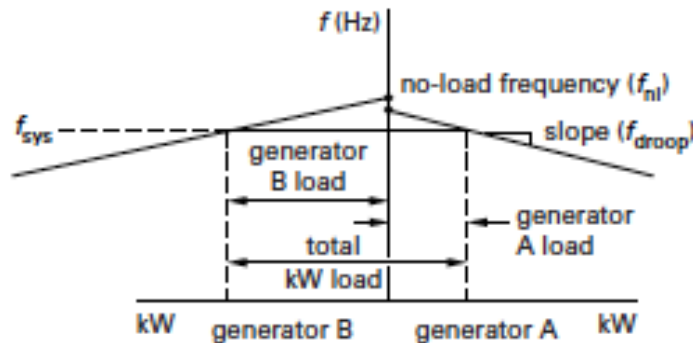

Figure 9: Real Load Sharing

P is the total real power carried by the generator, f_{sys} is the operating frequency of the system, and f_{nl} is the no-load frequency. The frequency droop, f_{droop} , is the slope of the speed characteristic line in units of Hz/kW.

Although negative, the frequency droop is often stated as a positive value. If the droop is given or used as a positive value, Eq. 7 becomes Eq. 8.

Equation 8: Positive Frequency Droop

$$P = \frac{f_{nl} - f_{sys}}{f_{droop}}$$



Electrical Power: Part I
A SunCam Online Continuing Education Course

The division of reactive load takes place in the same manner, but is controlled by the voltage regulators. Reactive load sharing is illustrated in Fig. 10. The reactive power carried by a generator is determined by Eq. 9.

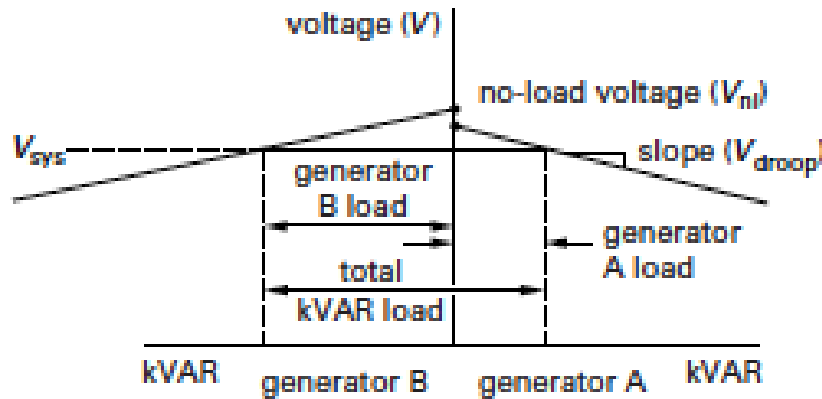

Figure 10: Reactive Load Sharing

Equation 9: Voltage Droop

$$Q = \frac{V_{sys} - V_{nl}}{V_{droop}}$$

If the droop is given or used as a positive value, Eq. 9 becomes Eq. 10.

Equation 10: Positive Voltage Droop

$$Q = \frac{V_{nl} - V_{sys}}{V_{droop}}$$

The slopes of the speed and voltage characteristic lines in Figs. 9 and 10 are normally given in percent change of rated frequency or voltage from a no-load to a full-load condition. These are called the *speed regulation* and *voltage regulation* of a generator, respectively.



Electrical Power: Part I
A SunCam Online Continuing Education Course

Example 3

A 1000 MW generator has a speed droop of 1%. Rated frequency is 60 Hz. If the generator carries 500 MW at 60 Hz, what is the no-load frequency setpoint of the speed-governing system?

Solution

A speed droop of 1% indicates a change in frequency of 0.01×60 Hz from 0 kW to 1000 MW, that is, from no-load to full load. Thus, the slope of the speed characteristic line, or curve, is 0.6 Hz/1000 MW. Because the droop is stated as a positive value, Eq. 8 is used.

$$P = \frac{f_{nl} - f_{sys}}{f_{droop}}$$
$$f_{nl} = P f_{droop} + f_{sys}$$
$$= (500 \text{ MW}) \left(\frac{0.6 \text{ Hz}}{1000 \text{ MW}} \right) + 60 \text{ Hz}$$
$$= 60.3 \text{ Hz}$$

DIRECT CURRENT GENERATORS

Direct current generators operate under the same principles as AC current generators, except the output is manipulated to provide the desired DC. The definitions of armature and stator remain the same as for AC generators, but their locations are reversed. The field of a DC generator is located on the stator, or stationary portion of the generator. The armature is located on the rotor, or rotating portion of the generator. This arrangement is used primarily because of the need to change the armature output to DC, which is accomplished by the *commutator*. *Commutation* is the process of current reversal in the



Electrical Power: Part I
A SunCam Online Continuing Education Course

armature windings that provides direct current to the brushes. Simplified commutation is shown in Fig. 11. The physical location of the windings and the electrical connections for a four-coil two-pole generator is shown in Fig. 12. The rotors are normally cylindrical. The DC output voltage is a rectified version of that shown in Fig. 8.

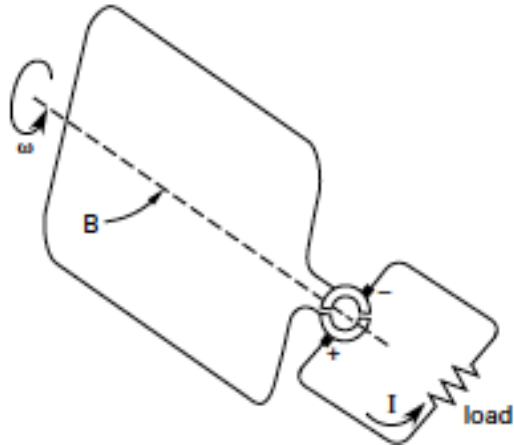

Figure 11: Commutator Action



Electrical Power: Part I
A SunCam Online Continuing Education Course

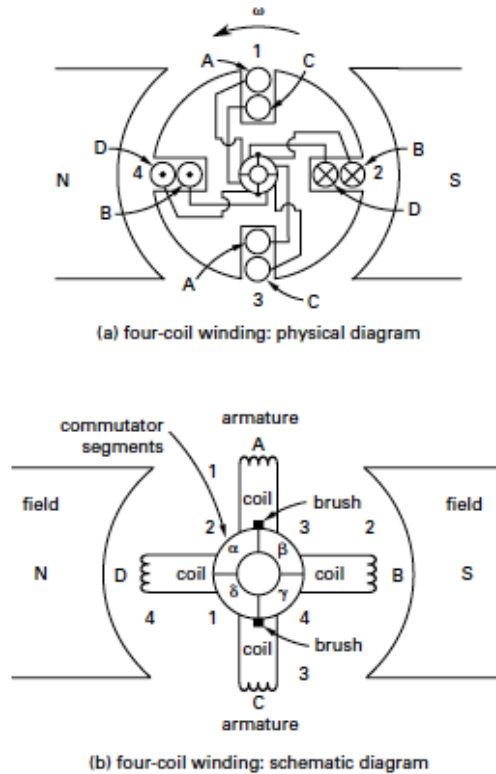

Figure 12: DC Machine Windings

Armature reaction is the interaction between the magnetic flux produced by the armature current and the magnetic flux produced by the field current. Armature reaction occurs in both AC and DC generators, lowering the output voltage. The reaction manifests itself by shifting the neutral plane as shown in Fig. 13.⁹

⁹ In generators, armature reaction shifts the neutral plane in the direction of angular motion. The effect occurs in DC motors as well, but the neutral plane shifts opposite the direction of angular motion.



Electrical Power: Part I
A SunCam Online Continuing Education Course

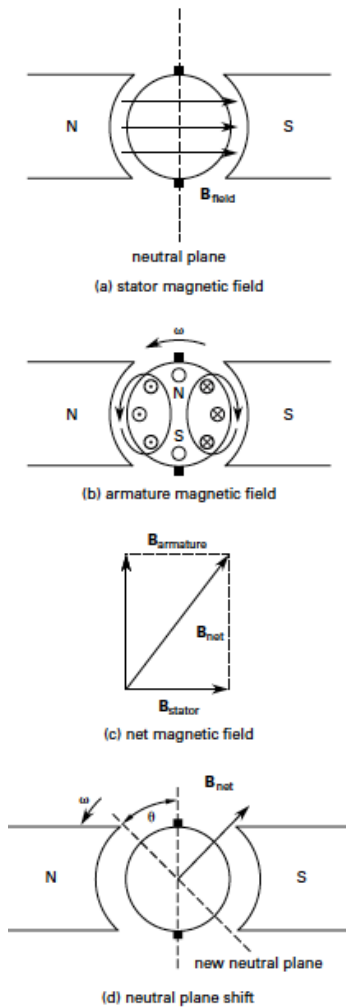

Figure 13: DC Generator Armature Flux

The neutral plane, also called the *neutral zone*, is the plane where the surface of the armature experiences a magnetic flux density of zero. In DC generators, the shifting of the *neutral plane* results in commutation occurring on coils that have a net voltage. Normally commutation, which shorts the coil connection, occurs when the net voltage on the coil is zero. With a voltage present in the coil, arcing at the brush commutator interface occurs as the coil is shorted. Such arcing lowers brush life and damages the commutator. The problem is solved in most DC machines by using *commutating poles* placed between the main field poles. The commutating poles oppose the



Electrical Power: Part I
A SunCam Online Continuing Education Course

armature magnetic field in the vicinity of the brushes. In large DC machines, the armature magnetic field is negated by *compensating windings* electrically in series with the armature windings but physically located in the field pole pieces. These solutions are illustrated in Fig. 14.

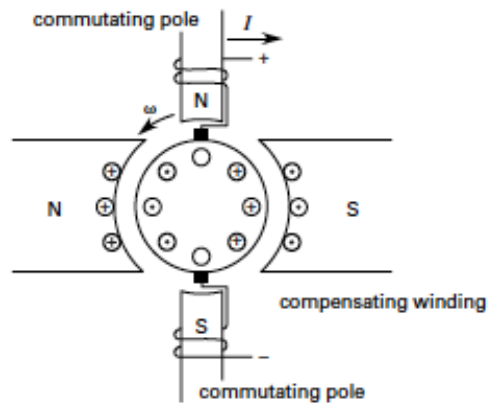

Figure 14: DC Machine Commutating Poles and Compensating Windings

Losses in a DC electrical generator include windage and friction; core; I^2R or copper losses in the armature; field, compensating, and commutating windings; and *shunt field*, load, and *brush I^2R* and *friction losses*.

POWER QUALITY

Power quality is defined by the equipment supplied. Each piece of electrical equipment has certain power supply requirements, which may vary considerably depending upon purpose and usage. The major areas of power quality follow and are illustrated in Fig. 15.



Electrical Power: Part I
A SunCam Online Continuing Education Course

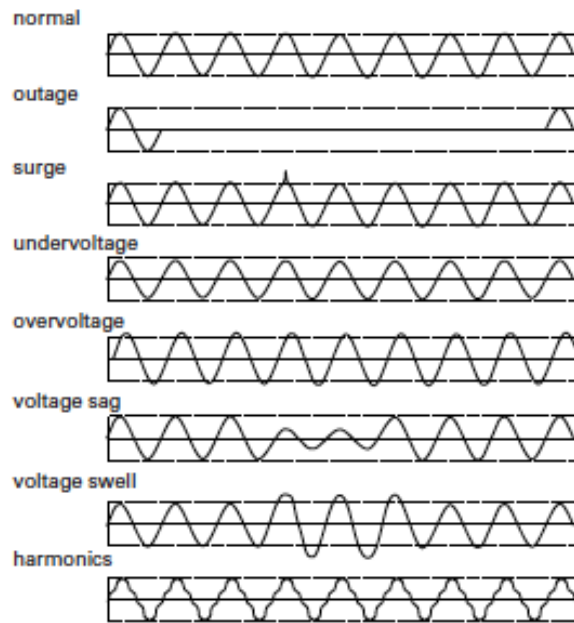

Figure 15: Power Disturbances

- *Outages*: a complete loss of electrical power. A *blackout* is a complete loss of voltage lasting from one cycle to several days. An outage condition results when faults cause protective devices to function. For example, circuit breakers may be caused to open or fuses to blow.
- *Surge*: a transient with a short duration and high magnitude. The term *spike* is used for peak voltages of 6000 V or more lasting approximately 100 μ s to one-half of a cycle. The term *transient* describes a peak voltage of 20,000 V or more, lasting 10 μ s to 100 μ s. Surges are caused by switching operations or lightning strikes.
- *Undervoltage*: voltage below the rated voltage for a long duration, that is, for several cycles.¹⁰ If the low-voltage condition lasts for an extended time, it is referred to as a *brownout*. Undervoltage conditions result from any number of factors, including loading beyond system capacity, failure of some sources on the grid, and ground faults in the system.

¹⁰ The ANSI standard for service rms voltage low limits is 110–114 V. See Ref. [H].



Electrical Power: Part I
A SunCam Online Continuing Education Course

- *Overvoltage*: an increase in the steady-state voltage that lasts for an extended time. It is also called chronic overvoltage.¹¹ Overvoltages are usually caused by improper regulation or voltage regulator failure.
- *Voltage sag*: a drop in voltage. If a low-voltage condition is 80–85% of its rated value for several cycles, the term *sag* or *dip* is used. Sags can result from faults or large starting currents.
- *Voltage swell*: a condition whereby a steady-state rise in voltage occurs for several seconds to approximately one minute.
- *Harmonics*: nonfundamental frequency components of the standard 60 Hz waveform, also called *line noise*. This can occur due to feedback from equipment connected to the line, radio frequency interference, and other electromagnetic sources.

¹¹ The ANSI standard for service rms overvoltage is 126 V. See Ref. [H].



Electrical Power: Part I
A SunCam Online Continuing Education Course

REFERENCES

- A. Camara, John A. *Electrical Engineering Reference Manual*. Belmont, CA: PPI, 2009.
- B. Camara, John A. *PE Power Reference Manual*. Belmont, CA: PPI (Kaplan), 2021.
- C. Marne, David J., and John A. Palmer. *National Electrical Safety Code® (NESC®) 2023 Handbook*. New York: McGraw Hill, 2023.
- D. Earley, Mark, ed. *NFPA 70, National Electrical Code Handbook*. Quincy, Massachusetts: NFPA, 2020.
- E. Keenan, Joseph H., et al. *Steam Tables. Thermodynamic Properties of Water Including Vapor, Liquid, , and Solid Phases (English Units)*. New York: Wiley & Sons, 1969.
- F. Camara, John A. *101 Solved Nuclear Engineering Problems*. Belmont, CA: PPI, 1999.
- G. Wildi, Theodore. *Electric Power Technology*. New York: Wiley & Sons, 1981.
- H. ANSI C84.1-2020. *Electric Power Systems Voltage Ratings (60 Hz)*. Arlington, VA: NEMA.



Electrical Power: Part I
A SunCam Online Continuing Education Course

Appendix A: Equivalent Units Of Derived And Common SI Units

Symbol	Equivalent Units			
A	C/s	W/V	V/W	$J/(s \times V)$
C	A×s	J/V	$(N \times m)/V$	V×F
F	C/V	C ² /J	s/W	$(A \times s)/V$
F/m	$C/(V \times m)$	$C^2/(J \times m)$	$C^2/(N \times m^2)$	$s/(\Omega \times m)$
H	W/A	$(V \times s)/A$	$\Omega \times s$	$(T \times m^2)/A$
Hz	1/s	s ⁻¹	cycles/s	radians/(2π × s)
J	N×m	V×C	W×s	$(kg \times m^2)/s^2$
m ² /s ²	J/kg	$(N \times m)/kg$	$(V \times C)/kg$	$(C \times m^2)/(A \times s^3)$
N	J/m	$(V \times C)/m$	$(W \times C)/(A \times m)$	$(kg \times m)/s^2$
N/A ²	$Wb/(N \times m^2)$	$(V \times s)/(N \times m^2)$	T/N	$1/(A \times m)$
Pa	N/m ²	J/m ³	$(W \times s)/m^3$	$kg/(m \times s^2)$
W	V/A	W/A ²	V ² /W	$(kg \times m^2)/(A^2 \times s^3)$
S	A/V	1/W	A ² /W	$(A^2 \times s^3)/(kg \times m^2)$
T	Wb/m ²	$N/(A \times m)$	$(N \times s)/(C \times m)$	$kg/(A \times s^2)$
V	J/C	W/A	C/F	$(kg \times m^2)/(A \times s^3)$
V/m	N/C	$W/(A \times m)$	$J/(A \times m \times s)$	$(kg \times m)/(A \times s^3)$
W	J/s	V×A	V ² /W	$(kg \times m^2)/s^3$
Wb	V×s	H×A	T/m ²	$(kg \times m^2)/(A \times s^2)$



Electrical Power: Part I
A SunCam Online Continuing Education Course

Appendix B: Physical Constants

Quantity	Symbol	US Customary	SI Units
Charge			
electron	e		$-1.6022 \times 10^{-19} \text{ C}$
proton	p		$+1.6022 \times 10^{-19} \text{ C}$
Density			
air [STP][32°F, (0°C)]		0.0805 lbm/ft ³	1.29 kg/m ³
air [70°F, (20°C), 1 atm]		0.0749 lbm/ft ³	1.20 kg/m ³
Gravitational Acceleration			
Earth [mean]	g	32.174 (32.2) ft/sec ²	9.8067 (9.81) m/s ²
Mass			
atomic mass unit	m_{∞} or m_{∞} $\frac{1}{12} m(^{12}\text{C})$	3.66 $\times 10^{-27}$ lbm	1.6606 $\times 10^{-27}$ kg or $10^{-3} \text{ kg mol}^{-1} / N_A$
electron rest mass	m_e	2.008×10^{-30} lbm	9.109×10^{-31} kg
neutron rest mass	m_n	3.693×10^{-27} lbm	1.675×10^{-27} kg
proton rest mass	m_p	3.688×10^{-27} lbm	1.672×10^{-27} kg
Pressure			
atmospheric		14.696 (14.7) lbf/in ²	$1.0133 \times 10^5 \text{ Pa}$
Temperature			
standard		32°F (492°R)	0°C (273 K)
Velocity³			
Earth escape		3.67×10^4 ft/sec	1.12×10^4 m/s
light (vacuum)	c, c ₀	9.84×10^8 ft/sec	$2.9979 (3.00) \times 10^8$ m/s
sound [air, STP]	a	1090 ft/sec	331 m/s
sound [air, 70°F, (20°C), 1 atm]	a	1130 ft/sec	344 ft/s
Volume			
Volume: molal ideal gas (STP) ⁴		359 ft ³ / lbmol	22.41 m ³ /kmol



Electrical Power: Part I
A SunCam Online Continuing Education Course

Table Notes

1. Units come from a variety of sources, but primarily from the Handbook of Chemistry and Physics, The Standard Handbook for Aeronautical and Astronautical Engineers, and the Electrical Engineering Reference Manual for the PE Exam. See also the NIST website at <https://pml.nist.gov/cuu/Constants/>.
2. Symbols shown for the solar system are those used by NASA. See <https://science.nasa.gov/resource/solar-system-symbols/>.
3. Velocity technically is a vector. It has direction.
4. The unit "lbmol" is an actual unit, not a misspelling.



Electrical Power: Part I
A SunCam Online Continuing Education Course

Appendix C: Fundamental Constants

Quantity	Symbols	US Customary	SI Units
Avogadro's number	N_A, L		$6.022 \times 10^{23} \text{ mol}^{-1}$
Bohr magneton	α_B		$9.2732 \times 10^{-24} \text{ J/T}$
Boltzmann constant	k	$5.65 \times 10^{-24} \text{ ft-lbf/}^\circ\text{R}$	$1.3805 \times 10^{-23} \text{ J/T}$
electron volt: $\left(\frac{e}{C}\right) \text{ J}$	eV		$1.602 \times 10^{-19} \text{ J}$
Faraday constant, $N_A e$	F		96485 C/mol
fine structure constant, inverse a^{-1}	a a^{-1}		7.297×10^{-3} ($\approx 1/137$) 137.035
gravitational constant	g_c	$32.174 \text{ lbf-ft/lbf-sec}^2$	
Newtonian gravitational constant	G	$3.44 \times 10^{-8} \text{ ft}^4 / \text{lbf-sec}^4$	$6.672 \times 10^{-11} \text{ N}\cdot\text{m}^2 / \text{kg}^2$
nuclear magneton	α_N		$5.050 \times 10^{-27} \text{ J/T}$
permeability of a vacuum	μ_0		$1.2566 \times 10^{-6} \text{ N/A}^2 \text{ (H/m)}$
permittivity of a vacuum, electric constant $1 / m_0 c^2$	ϵ_0		$8.854 \times 10^{-12} \text{ C}^2 / \text{N}\cdot\text{m}^2 \text{ (F/m)}$
Planck's constant	h		$6.6256 \times 10^{-34} \text{ J}\cdot\text{s}$
Planck's constant: $h/2\pi$	\hbar		$1.0546 \times 10^{-34} \text{ J}\cdot\text{s}$
Rydberg constant	R_∞		$1.097 \times 10^7 \text{ m}^{-1}$
specific gas constant, air	R	$53.3 \text{ ft-lbf/lbm-}^\circ\text{R}$	$287 \text{ J/kg}\cdot\text{K}$
Stefan-Boltzmann constant		$1.71 \times 10^{-9} \text{ BTU/ft}^2\text{-hr-}^\circ\text{R}^4$	$5.670 \times 10^{-8} \text{ W/m}^2\cdot\text{K}^4$
triple point, water		$32.02^\circ\text{F}, 0.0888 \text{ psia}$	$0.01109^\circ\text{C}, 0.6123 \text{ kPa}$
universal gas constant	R^*	$1545 \text{ ft-lbf/lbmol-}^\circ\text{R}$ $1.986 \text{ BTU/lbmol-}^\circ\text{R}$	$8314 \text{ J/kmol}\cdot\text{K}$



Electrical Power: Part I
A SunCam Online Continuing Education Course

Table Notes

1. Units come from a variety of sources, but primarily from the Handbook of Chemistry and Physics, The Standard Handbook for Aeronautical and Astronautical Engineers, and the Electrical Engineering Reference Manual for the PE Exam. See also the NIST website at <https://pml.nist.gov/cuu/Constants/>.



Electrical Power: Part I
A SunCam Online Continuing Education Course

Appendix D: Mathematical Constants

Quantity	Symbol	Value
Archimedes' constant (π)	π	3.1415926536
base of natural logs	e	2.7182818285
Euler's constant	C or γ	0.5772156649

Appendix E: The Greek Alphabet

A	a	alpha	N	ν	nu
B	b	beta	X	χ	xi
G	g	gamma	O	\omicron	omicron
D	d	delta	P	ρ	pi
E	e	epsilon	R	ρ	rho
Z	z	zeta	S	σ	sigma
H	h	eta	T	τ	tau
Q	q	theta	Υ	υ	upsilon
I	i	iota	F	ϕ	phi
K	k	kappa	C	χ	chi
L	λ	lambda	Υ	ψ	psi
M	m	mu	W	ω	omega



Electrical Power: Part I
A SunCam Online Continuing Education Course

Appendix F: Coordinate Systems & Related Operations

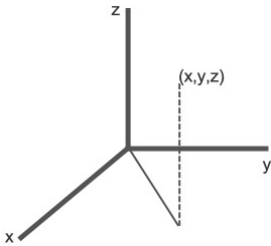
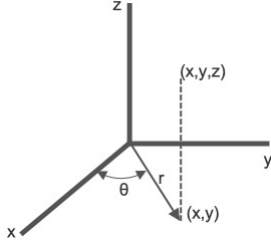
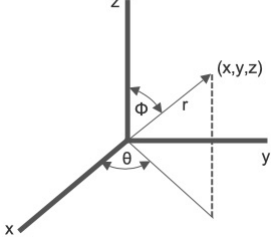
Mathematical Operations	Rectangular Coordinates	Cylindrical Coordinates	Spherical Coordinates
Conversion to Rectangular Coordinates	 $\begin{aligned}x &= x \\y &= y \\z &= z\end{aligned}$	 $\begin{aligned}x &= r \cos \theta \\y &= r \sin \theta \\z &= z\end{aligned}$	 $\begin{aligned}x &= r \sin \phi \cos \theta \\y &= r \sin \phi \sin \theta \\z &= r \cos \phi\end{aligned}$
Gradient	$\nabla f = \frac{\partial f}{\partial x} \mathbf{i} + \frac{\partial f}{\partial y} \mathbf{j} + \frac{\partial f}{\partial z} \mathbf{k}$	$\nabla f = \frac{\partial f}{\partial r} \mathbf{r} + \frac{1}{r} \frac{\partial f}{\partial \theta} \boldsymbol{\theta} + \frac{\partial f}{\partial z} \mathbf{k}$	$\nabla f = \frac{\partial f}{\partial r} \mathbf{r} + \frac{1}{r} \frac{\partial f}{\partial \phi} \boldsymbol{\phi} + \frac{1}{r \sin \phi} \frac{\partial f}{\partial \theta} \boldsymbol{\theta}$
Divergence	$\nabla \cdot \mathbf{A} = \frac{\partial A_x}{\partial x} + \frac{\partial A_y}{\partial y} + \frac{\partial A_z}{\partial z}$	$\nabla \cdot \mathbf{A} = \frac{1}{r} \frac{\partial (r A_r)}{\partial r} + \frac{1}{r} \frac{\partial A_\theta}{\partial \theta} + \frac{\partial A_z}{\partial z}$	$\nabla \cdot \mathbf{A} = \frac{1}{r^2} \frac{\partial (r^2 A_r)}{\partial r} + \frac{1}{r \sin \phi} \frac{\partial (A_\phi \sin \phi)}{\partial \phi} + \frac{1}{r \sin \phi} \frac{\partial A_\theta}{\partial \theta}$
Curl	$\nabla \times \mathbf{A} = \begin{vmatrix} \mathbf{i} & \mathbf{j} & \mathbf{k} \\ \frac{\partial}{\partial x} & \frac{\partial}{\partial y} & \frac{\partial}{\partial z} \\ A_x & A_y & A_z \end{vmatrix}$	$\nabla \times \mathbf{A} = \begin{vmatrix} \frac{1}{r} \mathbf{r} & \boldsymbol{\theta} & \frac{1}{r} \mathbf{k} \\ \frac{\partial}{\partial r} & \frac{\partial}{\partial \theta} & \frac{\partial}{\partial z} \\ A_r & A_\theta & A_z \end{vmatrix}$	$\nabla \times \mathbf{A} = \begin{vmatrix} \frac{1}{r^2 \sin \phi} \mathbf{r} & \frac{1}{r^2 \sin \phi} \boldsymbol{\phi} & \frac{1}{r} \boldsymbol{\theta} \\ \frac{\partial}{\partial r} & \frac{\partial}{\partial \phi} & \frac{\partial}{\partial \theta} \\ A_r & r A_\phi & r A_\theta A_r \end{vmatrix}$
Laplacian	$\nabla^2 f = \frac{\partial^2 f}{\partial x^2} + \frac{\partial^2 f}{\partial y^2} + \frac{\partial^2 f}{\partial z^2}$	$\nabla^2 f = \frac{1}{r} \frac{\partial r}{\partial r} \left(r \frac{\partial f}{\partial r} \right) + \frac{1}{r^2} \frac{\partial^2 f}{\partial \theta^2} + \frac{\partial^2 f}{\partial z^2}$	$\nabla^2 f = \frac{1}{r^2} \frac{\partial}{\partial r} \left(r^2 \frac{\partial f}{\partial r} \right) + \frac{1}{r^2 \sin \phi} \frac{\partial}{\partial \phi} \left(\sin \phi \frac{\partial f}{\partial \phi} \right) + \frac{1}{r^2 \sin^2 \phi} \left(\frac{\partial^2 f}{\partial \theta^2} \right)$