



*Fundamentals of Masonry – Part A*  
*A SunCam online continuing education course*

# Fundamentals of Masonry

## Part A

by

Professor Patrick L. Glon, P.E. (retired)



*Fundamentals of Masonry – Part A*  
*A SunCam online continuing education course*

## **Introduction**

The science of masonry construction is extensive, thorough, and is the foundation of the profession. But there is an artistic component bounded only by the imagination of the designer and the skilled mason.

Masonry construction has been practiced for thousands of years beginning with the ancient Greeks and the Romans. The “language” of the craft has been developed over this time. Today we use words that clearly identify pieces and parts of the industry that can bewilder or confound those unfamiliar with them – words such as wythe, shiner, and grapevine.

Masonry construction has exploded during the last century and a half due in large part to advances in manufacturing technology. For example, in the early years of manufacturing, each concrete block was made by hand – about 10 blocks per hour per man. Today, with modern machinery, production can be as high as 2,000 blocks per hour. And, each year around 4-billion concrete blocks are manufactured – enough to build about 3.5 billion square feet of wall. Up until about 150 years ago, clay bricks were made individually and by hand. Today, with modern machinery and kilns, about 50-billion clay bricks are manufactured each year – enough to build about 7.5 billion square feet of wall.

This two course series was created to provide fundamental knowledge about masonry construction for the engineer, contractor, architect, and anyone else who is interested in having a basic understanding of the topic.

### **Fundamentals of Masonry – Part A**

This course will explain and simplify the terminology and the fundamental principles of masonry and masonry construction including the nomenclature and history, the manufacturing process, bond patterns, mortar, including an introduction to the basic principles of wall construction.

It is fully illustrated with drawings and color photographs and is written in an easy to understand style.

Coming soon, **Fundamentals of Masonry – Part B** will discuss other kinds of masonry construction including stone and glass and a more thorough discussion of wall construction including some structural considerations; will show some real life damage resulting from sloppy and incorrect masonry construction practices, and some of the beauty and creativity of masonry.

Masonry is one of the most interesting and inventive methods of construction. Hopefully this will spark an interest in, and an appreciation of, the many aspects of masonry.



*Fundamentals of Masonry – Part A*  
*A SunCam online continuing education course*

### **A Bit of History**

Masonry construction is one of the oldest forms of construction dating back to prehistoric times when people stacked stones – placed one by one on top of each other – to form basic structures. At some point, maybe 12,000 years ago, which was around 10,000 BC, in the Middle East, **clay brick** was developed. (Or, perhaps to the ancient Egyptians if you hold the belief that humans were created 6,000 years ago.) These bricks were made by mixing clay with a reinforcing material – like straw – and then letting the sun bake them. This method of making brick lasted for about 6,500 years, when around 5,500 years ago (3,500 BC), again in the Middle East, kilns, rather than the sun, were used to bake the brick – kiln-fired brick were developed. Today, we still use the kiln-fired method of making clay brick in masonry construction. Of course, now, the technology is beyond anything those first kiln-fired brick makers could have ever imagined – even though the principle is exactly the same – using heat to bake a clay material to form bricks for masonry construction. Following is a short listing showing some of the important dates in masonry construction.

|           |  |
|-----------|--|
| 10,000 BC | the first sun dried clay bricks were made                                  |
| 3,500 BC  | the first kiln-fired clay brick units were made                            |
| 2,500 BC  | began using mortar made with sand and gypsum                               |
| 500+/- BC | began using mortar with sand and lime                                      |
| 50 AD+/-  | the first <u>concrete</u> brick units were made by Romans                  |
| 1824      | Portland cement <u>invented</u> – used in making concrete and later mortar |
| 1830's    | imitation stone units made with Portland cement based material             |
| 1940's    | the first paddle wheel barrel used for mixing mortar                       |

Notice the gap from the Romans (50+/- AD) to 1824? You may be saying to yourself “how could they have been making concrete bricks before Portland cement was invented?” The answer is “they weren’t!” The Romans actually used cement in the manufacture of concrete masonry units. Their concrete technology was lost after the fall of the Roman Empire and it wasn’t “invented” or “discovered” again until 1824. Wow.

### **Rain and Moisture**

Most structures built today have as their goal to be waterproof. The roof, walls, windows, doors, etc., are constructed with materials and methods of construction that prevent water from entering through the exterior shell of the building. Masonry construction is unique in that it allows water to penetrate into, and sometimes through, the wall. And based on this, the walls are constructed such that the water that enters a wall system is accounted for and allowed to safely drain away without reaching the interior of structures.

The amount of water that may pass through a properly constructed wall will depend a great deal on how much it rains and how hard the wind is blowing (wind driven rain). Weather records



*Fundamentals of Masonry – Part A*  
*A SunCam online continuing education course*

have been kept for well over a century and these records have been summarized and analyzed, and tendencies and patterns noted and plotted. Of course, these plots are weather maps. The two maps below show the wind pressure in pounds per square foot and the annual precipitation in inches for the United States.

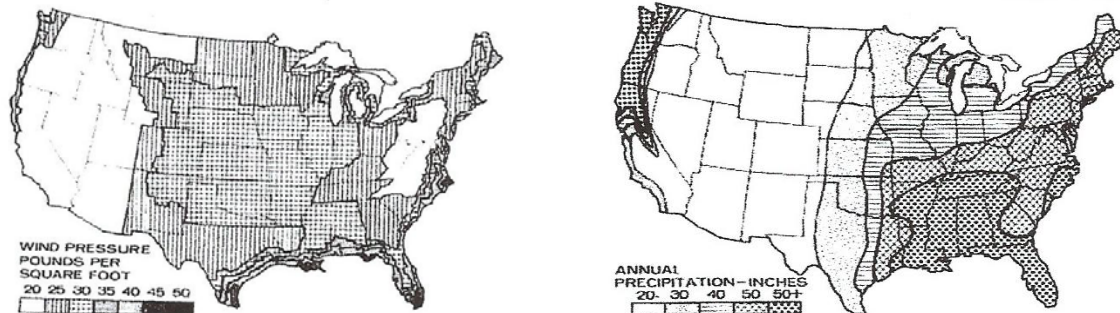

From the two maps it is difficult to determine the severity of wind driven rain. However, from these two maps, a Driving Rain Index (see credits) has been proposed which is based on the assumption that the likely-hood of rain penetration is proportional to the product of annual average rainfall and annual average wind speed. The results of this study have been plotted on the US map shown below.



So far, it seems reasonable to conclude that the severity of the weathering across the United States can be predicted with some degree of confidence. However, here is another map that shows a weathering system to be used as a guide for the severity of weathering for masonry construction (see credits).



*Fundamentals of Masonry – Part A*  
*A SunCam online continuing education course*

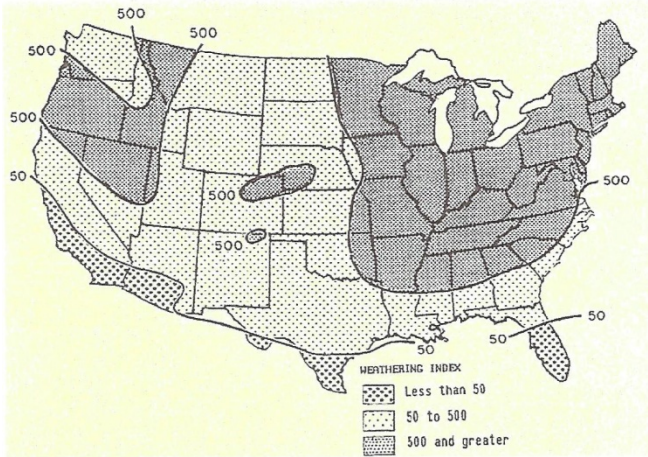

Notice the differences between the two US maps in where the severest weathering conditions occur across the US. As we can see, anticipating the severity of weather at a certain geographic location is NOT an exact science.

The variances between the maps are, in some cases, significant and there are extreme local variances within the marked zones of the maps. How do we determine whether moisture will even be a problem, whether a certain mortar joint can be successfully used to protect against water damage, or even if masonry construction is a viable option?

For designers, the answer to these questions lies within the building codes. It turns out that wind speed is not only a load the masonry wall must resist, but also the largest determinate as to the amount of water penetration into and/or through masonry walls. The building codes have their own set of wind speed maps drawn to a larger scale which allows for a little more “certainty” in predicting the severity of weather. The maps even show the boundaries of each county in the US.

The building codes begin with determining the basic wind speed from the maps and then adjusting that speed by considering various factors. There are code specifications for the specific location of a building, such as within a large city (with buildings over 70 feet high); urban and suburban areas; open terrain; and, flat, unobstructed area exposed to wind flowing over open water (including inland waterways, the Great Lakes, and the coastal areas of California, Washington, and Oregon). Hurricane regions have their own rules and regulations.

Other code sections take into account elevation – there are higher winds on top of mountains than on low ground, and tops of tall buildings are subjected to higher wind speeds than lower portions of the same building; local geography, such as near a steep slope or cliff or near mountainous terrain. And there is even a clause in the code stating the basic wind speed to be “...determined by the local jurisdiction...” under certain conditions.

All this is to say, that the imperfect construction of masonry must also deal with an imperfect determination of weather conditions – a balance between science and art.

### **Conventional Aspects of Masonry Units**

**Masonry unit** is the generic or default term given to the individual pieces of brick, block, stone, glass, or other material used in masonry construction. Think of “masonry unit” as the “coke” of soft drinks. (“Hey, want a coke?” “Sure what kind of cokes do you have?” “We have Coke,



*Fundamentals of Masonry – Part A*  
*A SunCam online continuing education course*

Pepsi, Dr. Pepper, Root Beer, and Orange.”) Similarly, a masonry unit can be of several different materials - clay, concrete, stone, etc. – and can have various sizes, shapes, colors, and structural and weathering properties.

Some of the descriptions for these masonry units have evolved over a long, long time – things like sizes, names, ratios of dimensions, etc. Since the advent of mass production back in the late 1800’s however, things in the masonry construction arena have begun to standardize – a bit.

Our discussion in this course, for the most part, will be limited to clay masonry units and concrete masonry units. As you might expect, clay masonry units are made with clay, and concrete masonry units are made with concrete. More on the manufacturing processes later.

The masonry units are held together with mortar. Mortar serves to make everything work together as a continuous unit – a wall, for example. There are different mortars for different uses and locations. And different joint finishes for different locations and uses.

Accessories are the multitude of items necessary to create functioning and stable masonry structures. Some of these items are wall ties, reinforcing, expansion joints, flashings, and weep holes. We will take a look at some of these too.

As we look at buildings today, it seems that most of the clay masonry units we see are “bricks” while most of the concrete masonry units we see are “blocks”. The truth of the matter is that there are also clay blocks just as there are also concrete bricks. Plus, there are a large variety of other special shapes and sizes for various special uses.

## Terminology

There is much terminology associated with the simple “brick”. Brick masonry has terminology that allows masons and designers, and others to communicate effectively. To the uninformed, the terms are at first confusing and seemingly arbitrary. However, they have been developed over hundreds, and even thousands of years. The Egyptians built with masonry, the Romans had structures of masonry, and currently we are building with masonry. For example, there are names for each of the six faces of a brick, names of some of the brick sizes and shapes, and names for the position that a brick is placed in the wall or structure.

A brick is a cube with three dimensions. It has a **length**, a **height**, and a **width** (sometimes

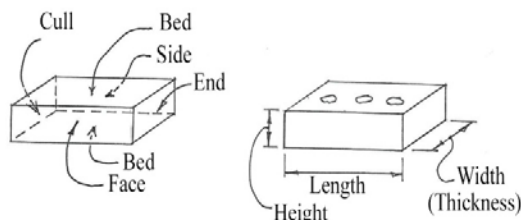

called thickness). A single brick has 6 surfaces (or faces) and each surface has a name. The long exposed side of a brick (length and height) is called the **face**. The back side of a brick is called a **side**. The two edges are called the **cull** and **end**. The top and bottom are called **beds** – there are two beds.



*Fundamentals of Masonry – Part A*  
A SunCam online continuing education course

| Brick Name                    | Exposed Face of Brick |
|-------------------------------|-----------------------|
| Stretcher                     | L x H exposed         |
| Header                        | W x H exposed         |
| Soldier                       | H x L exposed         |
| Sailor                        | W x L exposed         |
| Rowlock<br>(Bull Header)      | H x W exposed         |
| Rowlock Stretcher<br>(Shiner) | L x W exposed         |

Individual **clay bricks** can be laid in six different orientations within a wall, each with its own name, exposing one surface of the cube. The most commonly laid position is called **stretcher**. When a brick is laid as a stretcher, the face, i.e., the length and height, are the dimensions of the brick that can be seen after it has been laid.

**Headers** have the width and height exposed, and is used to connect two lengths of walls together for structural stability. **Soldiers** are typically used as headers above windows and doors. And,

**rowlocks** (bull headers) are commonly used as window sills. **Sailors** and **rowlock stretchers** (shiners) have special uses where they are not **exposed to weather**. A **snap header** is simply half of a header, usually broken in the field.

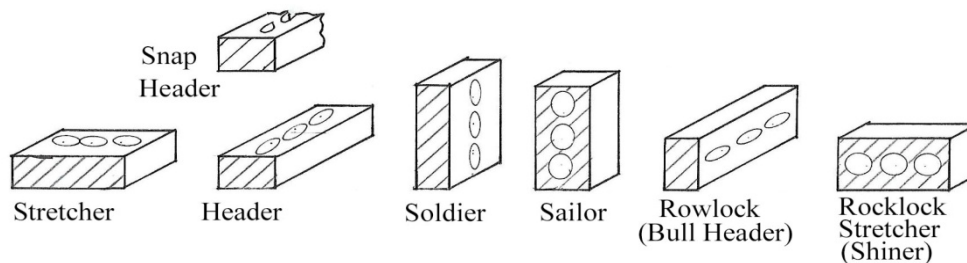

The drawing above shows **clay masonry units** standing in the various positions. Notice that the units have holes in them. Clay bricks typically have holes – from as few as three, up to six or eight holes, depending on their use, the manufacturing process, and other factors.

**Concrete bricks** typically have no holes as shown in the adjacent wall drawings. Notice that the rowlock stretcher in clay masonry is called a **shiner** in concrete brick masonry.

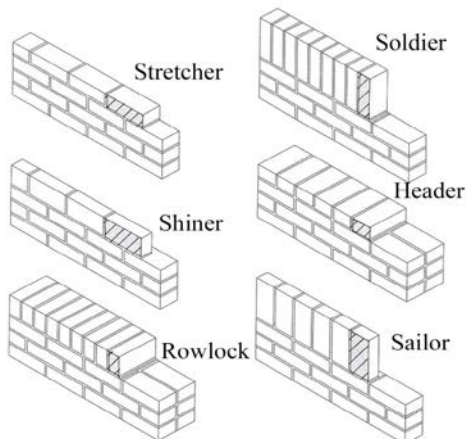

A **course** of brick is a continuous horizontal bond. Courses are measured, or counted, vertically. Each drawing on the left has 4 courses.

**Wythe** is the term given to each vertical section of wall one masonry unit in thickness – a wall one course of brick wide. The same wall made with two thicknesses of brick is two wythes, three thicknesses is three wythes, etc. In the concrete brick drawings, the stretcher, shiner, soldier, and sailor are one wythe. The header and rowlock are two wythes.



*Fundamentals of Masonry – Part A*  
A SunCam online continuing education course

### Dimensions of Masonry Units

There are dozens of different sizes of brick and block manufactured today, both of clay and of concrete. The dimension of each unit can be measured, or expressed, in three different ways. They are:

- Specified dimensions
- Actual dimensions
- Nominal dimension.

The **specified dimension** of a brick or block is the anticipated dimension of the unit after manufacture. It is the dimension used in job specifications and purchase orders. It is also the dimension used by structural engineers in the rational design of masonry structures.

The **actual dimension** of a brick or block is the precisely measured dimension of the unit after the manufacturing process is complete. The actual dimension should be within the tolerance specified in the ASTM standard specifications such as those in ASTM C216. For example, concrete block are to be manufactured to within 1/8 inch of the specified dimension. (Most block manufacturers, however, work to within one sixteenth of an inch.) The allowable tolerances vary and are dependent on the type and size of the unit.

The **nominal dimension** is the sum of the specified dimension of the unit plus the anticipated thickness of a mortar joint, which is usually 3/8 inch. For instance, a concrete block with a nominal dimension of 8 inches will be a block of a specified dimension of 7<sup>5</sup>/<sub>8</sub> inches plus a 3/8 inch mortar joint.

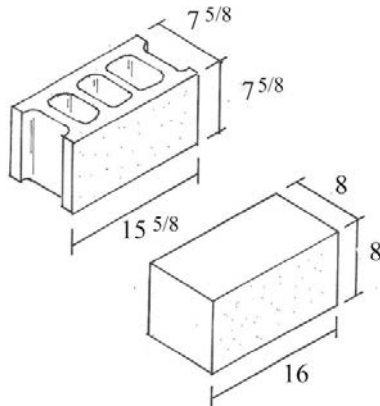

One of the most common concrete masonry units (CMU's) is the 8 inch block. Its nominal dimensions are 8 x 8 x 16 inches, and its specified dimensions are 7<sup>5</sup>/<sub>8</sub> x 7<sup>5</sup>/<sub>8</sub> x 15<sup>5</sup>/<sub>8</sub>. This typical block is also made in 4", 6", 10", and 12" widths. This type of block has a top and bottom face when laid. The face shells and webs are wider at the top than at the bottom to facilitate placement of mortar and support of the block above while being laid.

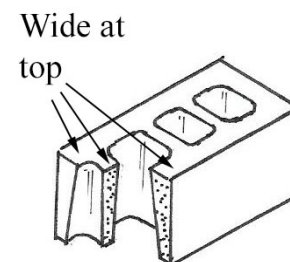

Clay brick masonry unit sizes can be either modular or non-modular. A **modular** sized brick is a brick with a nominal dimension that will lay up vertically in modules of a whole number of inches with no fraction. This module is usually, but not always, a multiple of 4-inches or 8-inches. For example, a brick with its specified dimension





*Fundamentals of Masonry – Part A*  
A SunCam online continuing education course

plus a 3/8 inch mortar joint may be 2<sup>2</sup>/<sub>3</sub> inches. Three courses of this brick plus its three mortar joints will total 8 inches. This brick would be a modular brick.

**Non-modular** brick do not lay up into a round number of inches. For example, a brick with a specified dimension of 2<sup>3</sup>/<sub>4</sub> inches high with a 3/8 inch mortar joint will not lay up in a modular dimension. It would lay up 3<sup>1</sup>/<sub>8</sub> inches high, multiple courses of which will not sum to exactly 4 or 8 inches.

The majority of masonry work done today is done with modular units, and therefore, modular dimensioning. Modular dimensioning means that the units will lay-up in increments of 4 or 8 inches. Many standard construction materials also use the 4-inch modular dimensioning – for example plywood sheets are 48 inches x 96 inches. Because of the common 4-inch modular dimension, it is relatively easy to design and construct structures using masonry construction.

| <b>Running Bond</b>  |   |                     |                                       |
|----------------------|---|---------------------|---------------------------------------|
| Brick Type<br>(Clay) | Nominal Size<br>(including one<br>3/8" joint)<br>W x H x L        | Modular<br>Coursing | Number of<br>Brick per<br>Square Foot |
| Modular              | 4 x 2 <sup>2</sup> / <sub>3</sub> x 8                             | 3 courses = 8"      | 6.75                                  |
| Engineer Modular     | 4 x 3 <sup>1</sup> / <sub>2</sub> x 8                             | 5 courses = 16"     | 5.63                                  |
| Closure Modular      | 4 x 4 x 8   | 1 course = 4"       | 4.50                                  |
| Fire                 | 4 <sup>1</sup> / <sub>2</sub> x 2 <sup>1</sup> / <sub>2</sub> x 9 | 2 courses = 5"      | 6.40                                  |
| Jumbo                | (6 or 8) x 4 x 12   | 1 course = 4"       | 3.00                                  |
| Roman                | 4 x 2 x 12  | 2 courses = 4"      | 6.00                                  |
| Norman               | 4 x 2 <sup>2</sup> / <sub>3</sub> x 12                            | 3 courses = 8"      | 4.50                                  |
| Engineer Norman      | 4 x 3 <sup>1</sup> / <sub>2</sub> x 12                            | 5 courses = 16"     | 3.75                                  |
| Utility              | 4 x 4 x 12  | 1 course = 4"       | 3.00                                  |

The table shows the nominal sizes of some common standard sized clay brick. The table also shows the module for multiple courses of brick as well as how many brick are in one square foot of wall surface when the pattern of laying the brick is running bond (which will be defined later).

bricks made today are about the same size as those made long ago – they fit easily and comfortably into the hand of a mason and they can be picked up one at a time, with one hand, and set in mortar.

From the earliest times of masonry construction, bricks have had certain dimensional relationships. The two most common relationships between a bricks length, width, and height are:

- Two brick widths plus one mortar joint equal one brick length, and
- Three brick heights plus two mortar joints equal one brick length.

Generally speaking, the

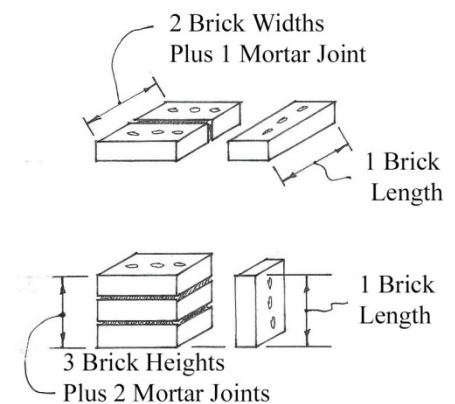



*Fundamentals of Masonry – Part A*  
A SunCam online continuing education course

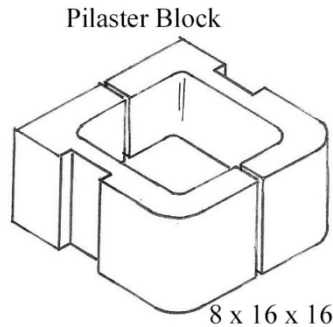

Just for fun, here are two special shaped concrete masonry units that are commonly used.

The pilaster block (two individual units laid in combination) is used to create columns or pilasters. Both are vertical reinforced structural members in walls.

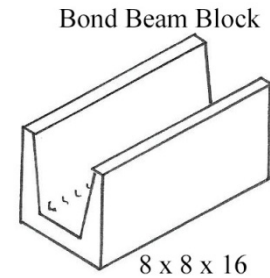

The bond beam block is used to create lintels or reinforced beams in masonry walls.

### Manufacturing of Clay Bricks

Clay bricks (units made from clay – as in clay soil) are relatively small and able to fit in the palm of the hand. The process to make the clay bricks is, in its basic procedure, the same today as it was in the time of the Egyptians. The several main differences in today's manufacturing process of clay bricks from that of long ago are:

- The efficiency with which they are made (today roughly 50 billion bricks are made each year);
- The “green” factor (today brick manufacturing is a very eco-friendly process);
- Their consistency (in size, color, water absorption rate, etc.); and
- The ability to consistently make bricks with different physical properties (because of today's advanced technology and knowledge of the raw material properties)

As an introduction to the process of manufacturing clay bricks, and to actually see how bricks were made up until the mid 1800's, the following sequence is from Colonial Williamsburg in Williamsburg, Virginia. Colonial Williamsburg is a living history museum and foundation centered on the colonial town of Williamsburg, Virginia as it was in 1775. They have reconstructed homes, taverns, shops, and other buildings from the colonial time period. They also have craftsmen and trade shops demonstrating such things as silversmith, leather working, brick making, blacksmith, and others as it was done in that time period. Would you like to know why a silk shirt under a wool sweater is warm in the winter and cool in the summer? Talk to the folks at the millinery where they make clothes without machines - by hand sewing.



*Fundamentals of Masonry – Part A*  
*A SunCam online continuing education course*

The photos below are from my visit to Colonial Williamsburg a few years ago.



In a nutshell, the basic method to manufacture clay brick is as follows: dig some clay from the ground, mix it with water, form it into the desired size and shape, air dry it, bake it in an oven, and finally cool it off. It is then ready for use.

**Mining the Clay** – The photo shows where clay soil has been dug with a shovel for use in making clay bricks. Of course, the leaves, sticks, and other debris are removed before digging to prevent contamination of the soil.



**Mixing the Clay with Water** – Here is the area where the excavated clay soil is deposited and mixed with water. In demonstrating this mixing process (**pugging**) today, children actually remove their shoes and socks and stomp in the mud. In the 17<sup>th</sup> and 18<sup>th</sup> century, slaves would do the pugging with bare feet.



**Forming the Brick Shapes** – Shown is a wooden form used to mold the clay bricks. The pugged clay and water material is packed into the form to make a relatively uniform size and shape brick.



**Air Drying the Brick Shapes** - The clay mixture is removed from the wooden form and set in the sun to air dry. After the bricks are air dried, they will be placed in an oven (kiln) to be baked (fired)



**Firing the Brick Shapes** – This photo shows a kiln and a large stack of firewood ready to be used to heat the kiln. The kiln itself now has an open top. And the open topped kiln is temporarily sheltered from the weather with a white overhead tarp. Notice the two openings at the bottom of the kiln on the side. These openings, and others, are used to feed the firewood into the kiln to maintain the heat to complete the firing of the brick.



*Fundamentals of Masonry – Part A*  
*A SunCam online continuing education course*



This is a photo showing a craftsman stacking the air dried bricks into the open topped kiln. Notice the openings in the wall near his feet. They are used to load firewood from the outside into the fully loaded kiln to fire the brick. Also notice the small spaces between each brick to allow air flow. Once the kiln is loaded, a top will be built to enclose the air dried bricks.

After the bricks are fired, they will be allowed to cool in the kiln. When cooled the top of the kiln will be removed and the finished bricks will be stacked and ready for use. Broken and otherwise damaged bricks are tossed into a pile to be recycled.

This is another photo showing the kiln in the far background, firewood to the right of the kiln, a long stack of brick in front of the kiln that will be used to seal the top of the loaded kiln, and a pile of broken and damaged brick – and a curious boy just messin’ around.



When this 18<sup>th</sup> century clay brick making process is completed, the bricks are ready for use in construction projects such as buildings, walls, patios, etc. within the village.

### **Efficiency**

From the very early times, several thousands of years ago, up until only about a century and a half ago, clay brick were manufactured one at a time as shown in the photo sequence above. In 1619, a patent was issued for a mechanical brick forming machine. This however didn't much change the brick making process. It wasn't until after 1858 that using mechanical means to make brick began to take off when the continuous kiln was introduced. Now, because of improvements in technology, some manufacturers can produce clay bricks at the rate of 50,000 per hour!

### **Green Factor (Environment)**

Since around the 1990's, when conservation and recycling was acknowledged as being important to the environment, clay brick manufacturing has become one of the most efficient industries - and therefore one of the most "green" activities - in the construction industry. There is virtually no waste of raw materials when manufacturing clay brick. And, because of the number of manufacturing facilities, most clay brick are used within 500 miles of where they are made.



*Fundamentals of Masonry – Part A*  
*A SunCam online continuing education course*

Sustainability, and therefore the impact on the environment, in the manufacture and use of clay brick is accomplished by:

- Locating the manufacturing plants near the clay mines to reduce transportation
- Reclaiming the land where mining has occurred
- Taking steps to reduce manufacturing plant emissions, e.g., by using excess heat from the cooling process to air dry bricks
- Recycling materials by reusing water and heat from the manufacturing process and by crushing and grinding defective bricks for use in landscaping, baseball diamond infields, and reusing in making new bricks

## Clay

Clay, the raw material for the manufacture of clay bricks, is a naturally occurring soil of the earth. Being a naturally occurring material, all clays are not identical. Different clays have different physical properties. However, all clays have nearly (but not quite) the same chemical properties. Generally speaking, clays are divided into three types – **surface clays**, **fire clays**, and **shale**.

**Surface clays** are clays that are found near the surface of the earth. The bricks made at Colonial Williamsburg in the previous example are made with surface clay.

**Fire clays** are clays that are found deeper in the earth. They are mined from deeper in the pit, or from mining shafts underground. They have more uniform chemical and physical properties than surface clays and shales. Fire clays also have fewer impurities and are more resistant to heat. This heat resistance is a good quality because clay bricks can be used as a fireproofing technique in buildings. The fire clays are a bit harder to work than surface clays and shale.

**Shale** is simply a clay material that has been subjected to high enough pressures for a long enough time to make shale. And, the pressure has not been high enough or the time long enough to harden the shale into slate.

Not all clays by themselves are suitable for making bricks to today's high standards. The three different clays as excavated can be proportionally combined, depending on their specific properties, to form a homogenous mixture suitable for consistently making bricks with similar properties over several batches or runs. The clays used today must also meet the rigid standards for plasticity, holding their shape after forming, and properly solidifying when fired. The variability of impurities in the different clays and shales – especially iron, magnesium, and calcium – are one of the main influences on the variation of colors in clay bricks.



*Fundamentals of Masonry – Part A*  
*A SunCam online continuing education course*

## **Mining**

Mining consists of removing the clay material from the earth using power equipment. In the masonry business, mining is referred to as **winning** – an ancient word derived from the word “win” which means “...to make one’s way with effort; or, to discover and open a vein or deposit in mining; or, to extract from a mine...”

After winning, the clay is stockpiled, usually undercover, at the manufacturing plant. The clays from the different sources are placed in different areas to keep them separated for blending later. The blending of the various clays is accomplished by first removing large stones, then crushing the raw clays and shales to break up large chunks. Then large grinding wheels mix and reduce the various different clays to a fine, homogeneous material. Often, the mixed clay material is run through graded sieves to control particle size.

Consistency in the clay mix is necessary to produce a uniform color and other properties during manufacture of brick. Uniformity of brick color is desirable throughout a project, and from project to project within a complex – such as a hospital or college campus. Matching brick color can be an issue.

Tempering is the final step prior to forming the bricks. Tempering is another name for pugging. It is accomplished by running the mixed and graded clay and water through the pug mill. After pugging, the clay is a moist, homogenous, plastic mass ready to be formed into bricks.

## **Forming**

There are three ways to form bricks. Which one is used depends on the actual physical properties of the clay. The **three** ways are:

1. Stiff-Mud Process
2. Soft-Mud Process, and
3. Dry-Press Process

The majority of brick manufactured today – perhaps 90% - are formed using a process called **Stiff-Mud Process**. The stiff-mud process is an extrusion process and used with clays containing 10 to 15 percent water. After the clay is thoroughly pugged, it is put in a vacuum chamber. Here some of the air holes and bubbles are removed from the water-clay mixture to increase the workability and plasticity of the clay. This results in greater strength. The water-clay mass is then extruded through a die producing a long, continuous rectangular shaped “rope” of clay. This rope is then cut into individual bricks which are ready for the next step in the brick making process.



*Fundamentals of Masonry – Part A*  
*A SunCam online continuing education course*

A second common method to form the individual bricks is called the **Soft-Mud Process**. This process is used for clays that are too wet (20 to 30 percent water) to be extruded using the stiff-mud process. After pugging, the clay is simply placed into forms, or molds, by using power equipment. To prevent the clay from sticking to the molds, either sand or water is used to coat the molds. This results in either “sand-struck” or “water-struck” bricks. After removing the formed bricks from the molds, they are ready for the next step of the manufacturing process.

A third method of forming bricks from pugged clay is called the **Dry-Press Process**. In this method, clay pugged with a small amount of water (10 percent or less) is pressed into steel molds using pressures of 500 to 1500 psi. This is a mechanical process using hydraulic or compressed air rams. After the bricks are removed from the forms, they are ready for the next step in the manufacturing process.

### **Kilns**

There are several types of kilns; two of the most common are the periodic and the tunnel. These kilns are heated using coal, gas, propane, oil, sawdust, or combinations of these fuels. A **periodic kiln** is a highly sophisticated bit of equipment. It is loaded, fired, cooled, and then unloaded. Then the cycle begins again.

A **tunnel kiln** is continuously operated and is also a highly sophisticated piece of equipment. It has sensors, monitors, and other equipment in various zones along its length to strictly control the temperature, humidity, and time that the bricks spend in each zone. Miss-steps in these controls can cause cracking in the bricks and undesirable color variations. A high percentage of modern brick manufacturers today use tunnel kilns for drying and firing bricks.

### **Evaporation**

The next step in the manufacture of clay bricks is **evaporation** (drying). Bricks are no longer set in the sun to air dry. They are placed in a kiln and so are actually considered a part of the firing of brick, which is discussed next. During the drying stage, the free water is evaporated out of the bricks.

Bricks are **hacked** (placed) onto a cart called a **kiln car**. The bricks are stacked in special patterns to allow heat to flow freely between the bricks. Hacking is typically done with robots or other machines. Notice that, back in the photographs of the brick making process in Colonial Williamsburg, the photo showing the craftsman placing the brick into the open kiln, there is an air space between each brick.

The hacked kiln car is sent into the tunnel kiln for the beginning of its journey to become a clay brick, ready for use. Most often, in keeping with the “green factor”, the heat for the drying portion of the process is supplied as exhaust heat from the firing portion of the kiln. The clay



*Fundamentals of Masonry – Part A*  
*A SunCam online continuing education course*

bricks enter the kiln with moisture contents varying from 7 to 30 percent, and spend from 24 to 48 hours in temperatures ranging from 100 °F to 400 °F.

**NOTE:** The temperature ranges shown for the following processes may seem to overlap during the firing process. They don't. They simply differ from batch to batch, and manufacturing plant to plant, depending on the beginning properties of the clays, and the final product being produced,

### **Firing**

**Firing** generally includes **six stages**. In addition to evaporation (above), the other five are **(1) dehydration, (2) oxidation, (3) vitrification, (4) flashing, and (5) cooling**. It can take from 40 up to 150 hours for the kiln cart to complete the journey through the tunnel kiln depending on the type and chemical composition of the clays used, the initial moisture content, the final color desired, the size and number of bricks, and number of holes (corings) in each brick. The first four stages occur at ever increasing temperatures.

After the free water, the “wet” water, is evaporated during drying, **(1) dehydration** removes the water molecules bound up with the clay particles. Dehydration of the bricks will occur at temperatures ranging from 300 °F to 1,800 °F.

The temperature of the bricks continue to rise from about 1,000 °F to about 1,800 °F as the kiln cart moves through the tunnel kiln. Here **(2) oxidation** can occur. Because all clays contain oxides, and the most common oxide is iron, most bricks will end up some shade of red if it is exposed to an oxidizing fire – which is a fire produced with an excessive amount of oxygen. Regardless of its original natural color, clay containing iron in practically any form will force the iron to form ferrous oxide and generate the red hue so common in brick. This same clay brick, if fired with a reducing flame – a fire produced with low oxygen – a deoxidized atmosphere – it will end up with a dark or purple color. Creating a deoxidized or reducing atmosphere, is known as **(4) flashing** or reduction firing.

The temperature along the tunnel kiln is raised to around 1,600 °F to 2,400 °F. At this temperature **(3) vitrification** of the bricks occurs. As it turns out, clay will soften and melt slowly as the temperature rises and it will vitrify. Vitrify means to “...change or make into glass or a similar substance, especially through heat fusion...” Clay will become a solid and hard mass and have a relatively low absorption rate when it vitrifies.

Here's the real tricky part of vitrification. As the temperature rises, and the clay melts, it will pass through three stages –

1. Incipient fusion - when the clay particles become sufficiently soft to stick together in a mass when it is cooled,





*Fundamentals of Masonry – Part A*  
*A SunCam online continuing education course*

2. Vitrification – when the clay is on the verge of flowing; it becomes tight, solid, and non-absorbent, and
3. Viscous fusion – when the clay mass becomes molten and breaks down becoming deformed.

During the vitrification firing of the bricks, the trick is to control the temperature, and the time in that temperature, so that incipient fusion and partial vitrification occur without having viscous fusion happen. If the process is not carefully controlled, the clay will go into viscous fusion where the brick begins to deform, slump, or even puddle on the kiln cart. The photo on the right shows an example of a column built using clay bricks subjected to viscous fusion. Interesting.



And finally the last step is **(5) cooling**. After the firing is complete, and the bricks have been heated to the proper temperatures and maintained at those temperatures for the appropriate times, the bricks are cooled in the tunnel kiln. The cooling process is important because the rate of cooling has a direct effect on color. In a tunnel kiln, the cooling time is usually less than 48 hours. Proper cooling in a periodic kiln can take from 48 to 72 hours. Cooling too rapidly can cause bricks to crack and to change color.

Again, the heat given off during the cooling process is “recycled” as heat used in the drying process. When the cooling is done, the loaded kiln cars are removed from the kiln and made ready for packaging and shipping. The process of unloading the bricks from the kiln car after firing is called **de-hacking**.

The brick are then sorted, graded, and packaged ready for storage in the yard or for shipping.

### **Manufacturing of Concrete Masonry Units**

The manufacture of **concrete masonry units** includes the many shapes of concrete blocks and concrete bricks. In the early years, each concrete block was made by hand at the rate of about 10 blocks per hour per man. Today, the largest plants in the nation with the most modern and technically advanced machinery and equipment can produce as many as 2,000 blocks per hour.

In April of 2019, I visited the Hagen Cement Products, Inc., a block manufacturing plant in White Pigeon, Michigan. The plant is located on a 60 acre site. The facility is owned and operated by the Hagen family and has been in business since 1947. Terry Hagen, the manager of the facility, was kind enough to answer some questions and to allow me to walk through the plant and take some photographs.



*Fundamentals of Masonry – Part A*  
*A SunCam online continuing education course*

The Hagen facility is a medium sized block making plant. Terry and his family can manufacture up to 8,500 standard sized 8” blocks per day (a 9 hour shift) and they typically sell around 1.2 million blocks per year. Block making plants are disappearing as time goes by. We are lucky to have a modern, up to date CMU manufacturing facility in our area.

On the day I visited they were manufacturing 8” CMU’s. The photos will necessarily show the 8” blocks during various phases of the manufacturing process. However, the manufacturing process is the same for producing all sized and shaped units.

Simply speaking, concrete block are made by combining Class I Portland cement, aggregate, and water and placing the concrete mix into a steel form of the desired shape. The block shaped concrete is immediately removed from the form and placed in a kiln to cure. The curing is done in the presence of steam and a hot water mist. After curing, the blocks are stacked and ready for sale and use. Note that the end product is NOT cement blocks or cement bricks, as they are sometimes called. Cement is but one ingredient in the concrete used to make the CONCRETE blocks and bricks.

For a more thorough discussion of concrete and its properties, see the SunCam course titled Fundamentals of Concrete by Pat Glon.

Hagen acquires the raw materials needed for manufacturing concrete block from several sources.



The Class I Portland cement is purchased in bulk. The sand and p-gravel used is mined from a 45 foot deep lake on site. Sid Hagen dredges and runs the material through sieves, and stockpiles it for future use. The expanded shale aggregate they need is purchased from a firm in Indianapolis, and the limestone aggregate is purchased from a company in Fort Wayne. The admixtures used in the mix are also purchased. Very little water is used and it is simply potable water

from the well system. Note: the concrete mixture used in manufacturing CMU’s must be a stiff mix, unlike the ready mixed concrete normally seen on a construction site.



## Fundamentals of Masonry – Part A

### A SunCam online continuing education course



Once the raw materials are near the plant, the manufacturing process can begin. The photo shows p-gravel dumped into a bin being conveyed up to the mixing tower. Sand is stockpiled to the left in the photo, and cement is in the vertical cylindrical tower in the far background. A wire caged plastic container of admixture solution is in the background to the right in the photo.

The first step is to thoroughly mix the sand and gravel. Prior to mixing, the two ingredients are **pre-watered** with a small amount of water.



The mixer (hopper) has probes (sensors) to measure the moisture content of the sand and gravel. That moisture is taken into account when determining how much pre-water to add. Sometimes the aggregate is too wet to make concrete block and the run is cancelled until it dries out. The photo shows the mixed aggregate being carried up to the final mixing drum where the proper amount of cement, admixture, and remainder of water, **final-water**, is added and thoroughly mixed in a rotating drum.



The concrete mixture is then transferred by conveyor belt to the top of the block forming machine. This machine precisely measures the amount of concrete to deposit into the mold in the machine. This concrete, after being deposited into the mold, is vibrated, compresses for about a second and a half, vibrated some more, and again compressed for another second or so. Three compacted and compressed formed blocks of uncured concrete are then pushed out the bottom of the mold and placed onto a conveyor line. The photo shows Scott Hagen standing by the forming machine with blocks exiting the machine and placed on the line. It is hard to see in the photo but the three blocks are actually placed onto a rectangular steel pallet approximately 28" wide by about 20" long by about 1/4-inch thick which will carry the block along its entire journey until near the end of the line.



*Fundamentals of Masonry – Part A*  
*A SunCam online continuing education course*

The mold makes three 8” blocks per cycle. The day I was there, blocks were being formed at the rate of about 6.2 cycles per minute – or about 10 seconds per cycle. At this point the blocks are very fragile. If they are bumped or otherwise jarred, they will fall apart. They travel about six feet along the conveyor where they are passed under a circular roller brush – three at a time – and brushed along the top surface to remove any crumbs that remain on the top of the newly formed block. The brushing operation can be seen in the previous photo.



The steel pallet carrying the three blocks is then moved along the line and, at the appropriate location, automatically pushed into the kiln. The kiln consists of four “bays”, with each bay containing four columns of shelves. Each column is 8 shelves high. And each shelf is long enough to accommodate 29 steel pallets carrying concrete product.

The photo shows a pallet of three 8” blocks being pushed onto a “shelf” in the first column of the third bay from the rear. The first two bays have an insulated visqueen curtain drawn over the front of the fully loaded kilns. At three blocks per pallet x 29 pallets per shelf x 8 shelves per column x 4 columns per bay equal 2,784 blocks per kiln bay, times 4 bays equal 11,136 block (8 x 8 x 16) capacity for the entire kiln of four bays.

Over a 9 hour shift, which includes intermittent stoppages of the line for lunch and other various reasons, and eliminating damaged units, Hagen’s produces somewhere between 8,000 and 8,500 8” concrete block per day. Another way to calculate the output in a 9 hour shift is: about 6 cycles per minute times 3 blocks per cycle  $\approx$  18 blocks per minute  $\approx$  1,080 per hour times 7.5 +/- hours total run time  $\approx$  8,000 – 8” blocks per shift (per day).

The eight-inch concrete masonry units remain in the kiln for about 24 hours – or until the next run. The curing process actually takes around 4 to 5 hours. Water is boiled and steam and a hot water mist are introduced into each bay for the appropriate time. The conditions in the kiln are similar to a wet sauna or a steam room (temperatures usually from 90°F to 120°F). This effectively cures the concrete in a controlled, efficient, and quick manner.



## Fundamentals of Masonry – Part A

### A SunCam online continuing education course



The block will then stay in the kiln until the next production run is begun. As it turned out, the last production run was over a week ago. Hagen's had plenty of CMU's on site ready for sale, and there was no need to move the block out of the kiln until the day of their next production run. As this current production run progresses, and a steel pallet carrying three freshly formed 8" block is pushed into the other side of the kiln, a steel pallet carrying product from the previous run is pushed out this side of the kiln as shown in the

photo. In this case, the last run was also 8" normal weight concrete blocks, three at a time. When all of the existing product, and their steel pallets, are removed from the kilns, the fresh product is ready to be cured with steam and hot water mist.

Some of the major differences in the curing process between clay masonry units and concrete masonry units are the

- Temperatures of the kiln – clay high temps, concrete low temps
- Time in the kiln – long for clay, short for concrete
- Objective of the kiln – clay to remove water, concrete to maintain water
- Process – clay to melt and bake the material, concrete to cure the material

The cured block, after leaving the kiln, begins the journey to final stacking into cubes. On their way, the product, in this case 8" block, is visually inspected and damaged or otherwise unacceptable blocks are removed from the line. The rest are rotated, rearranged, and oriented to be placed into position to create four or five layers of block in the shape of a cube. A cube that will not fall apart when picked up and moved, and that is not too heavy to lift with standard fork lift equipment.



The first stop after leaving the kiln, on the journey to cubing, is shown in the photo. The passing blocks are automatically counted as they pass through the machine. Some blocks are rotated 90 degrees to align the cores of the bottom layer of block in the final cube to receive the forks from a piece of equipment to lift the cube. Ingenious! Also, at this station, the blocks are separated from their steel pallets, and the pallets are returned back to the beginning



*Fundamentals of Masonry – Part A*  
*A SunCam online continuing education course*

of the process to receive freshly formed new product, either the continuation of this run, or in the next run.



Further down the line, sets of three blocks are re-arranged so that an 8” wide end of two individual blocks are butted flush up against the 16” side of the third block. This ultimately forms interlocking patterns in the layers of the final cube to prevent falling apart during shipping and handling.



Six groups of three blocks are then arranged on a table to form a single layer of 18 thoughtfully positioned blocks. When this layer is moved aside, another layer is created, with this new group of 18 arranged in a different configuration and oriented 90 degrees to the previous layer. It is then stacked on top of the first layer. This continues for four or five layers, creating a cube of blocks – a pallet – of either 72 or 90 blocks.

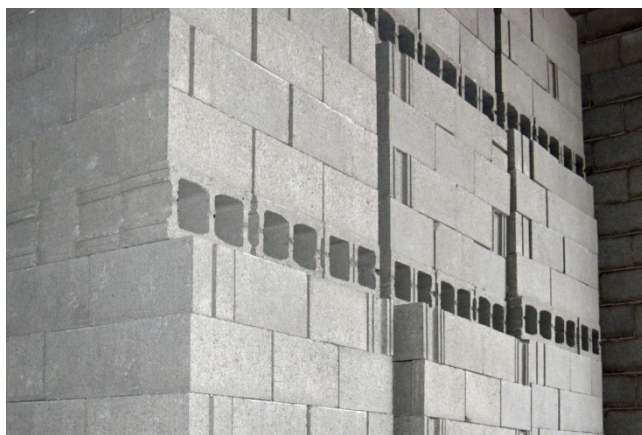

This pallet of blocks is then transferred with a fork lift to its storage place in the yard. Notice the holes in the bottom layer of each cube to receive the forks for the lifting equipment. These CMU’s are now ready for sale and delivery to a construction site.

Quality control is important in the manufacturing of concrete masonry units and there are many of the same technical aspects involved with the type and quality of the ingredients, forming, and curing as in the manufacture of clay brick.

The manufacturing process at Hagen’s is similar to the other plants across the country. Many different concrete products can be produced with this equipment. The sizes and shapes of the



*Fundamentals of Masonry – Part A*  
*A SunCam online continuing education course*

CMU is limited only by the size and shape of the form that will fit into the forming piece of equipment shown at the beginning. If the form will fit into the machine, this operation can manufacture the product. It turns out that the largest sized unit that Hagen's makes is a 14" block. Of course, the curing conditions must be adjusted to properly cure the different products. A few of the products made by Hagen's are shown in the photos.



## **Mortar**

**Mortar** is the stuff that bonds the individual masonry units together to form larger, complete masonry structures. Mortar allows the pieces of masonry construction to act as a single element.

When mortar is initially mixed, it is a buttery, plastic consistency. This mixture is then applied to the masonry units which are then set in place. The mortar then cures, or hydrates, until it is hard and able to withstand the weathering forces of nature – especially by resisting the entrance of water and air.

In the past, mortar has been made from many different materials. In ancient Egypt, for example, mortar was made from burned gypsum, sand, and water. In the United States before the 1900's, mortar was made from lime, sand, and water.



*Fundamentals of Masonry – Part A*  
*A SunCam online continuing education course*

Today, mortar is made from a combination of **lime**; one or more **cementitious materials** (Portland cement, mortar cement, masonry cement); clean well graded **sand**; and enough **water** to give a plastic workable mixture.

### **Mortar versus Concrete**

Before going much further, we should discuss the differences between mortar and concrete. Even though they can have the same ingredients – Portland cement, aggregate, and water – they have different functions, they behave differently, and they have different strengths.

Concrete is a structural unit. Mortar is the bonding agent that allows individual masonry units to form a complete solid mass. Concrete can have compressive stresses as high as 10,000 psi, whereas mortar seldom has compressive stresses as high as 3,000 psi. Concrete uses large aggregate, up to 1-1/2 inches in diameter, while mortar uses only sand.

Mortar and concrete cure differently. When concrete cures, it is very important that the water in the mix is allowed to chemically combine with the cement – to hydrate. There is a great emphasis on keeping the water in the mix during the hydration process. Once the ingredients for concrete are combined, it is important to maintain close control over how much water is added to the mix. Mortar, after the ingredients are combined, can have additional water added to re-hydrate, or re-temper, the mix for up to two, and perhaps up to two and one half hours.

In concrete, the water/cement ratio must be maintained during the placing and curing process. When the mortar is placed between masonry units, the absorbent units will suck water out of the mortar mix.

(NOTE: For additional information about concrete consider taking the Fundamentals of Concrete course offered by SunCam.)

### **General**

Mixing a batch of mortar is simple in concept. Just combine a **cement, lime, and sand** with enough **water** to make a **buttery mix**. Of course, those ingredients must be in the proper proportions, but that is essentially it.

When selecting the Type or Types of mortar for each project, the decision should be based on the construction requirements, the geographic area of the country, the climatic conditions, the quality of workmanship of the available workers, as well as on the performance requirements of the completed structure. For example, will the completed masonry work be underground or be used as a retaining wall? Will it be in a cold climate? Will it be where salt water spray is common? Or both? Will the consistency of the color of the mortar be an important factor? Will the masonry structure be subject to high lateral loads from wind or seismic activity? Will the





*Fundamentals of Masonry – Part A*  
*A SunCam online continuing education course*

workability of the mortar be the governing criteria for the mortar selection? The different properties of mortar can be matched to the building and functional requirements of the project.

The underlying rule to selecting a Type of mortar is that no single Type of mortar is the best for all uses. We engineers can sometimes get hung up on selecting a mortar Type based on compressive strength alone. The compressive strength is a nice, easily comparative number that is easily understood. However, when selecting mortar, that is not always the best criteria. As a general rule, the strength of the mortar should be just high enough to meet the minimum project strength requirements.

### Types of Mortar

There are four different mortar Types according to ASTM C270, Standard Specifications for Mortar for Masonry. They are Type M, Type S, Type N, and Type O. The acronym “mason work” can be used to remember the types of mortar. They chose every other letter of the phrase “mason work”. **MaSoN wOrk**. There is no longer a Type K mortar. They didn’t want to identify the different Types of mortars as Type 1, Type 2, etc., or Type A, Type B, etc., because those identifiers imply there might be some sort of rank order. There isn’t.

An easy way to select a mortar mix for a project is to remember a catchy phrase:

- Type N for normal applications – Type S for stronger applications

### Ingredients

There are four basic ingredients used to make mortar. They are **(1) lime, (2) a cementitious material, (3) sand, and (4) water.**

**(1) Hydrated lime** is added to a mortar mix to influence the bond, workability, water retention and elasticity of the mortar. Hydrated lime is produced by chemically altering limestone, which, among other things, produces calcium hydroxide.

There are three different kinds of **(2) cementitious material** used to make mortar. They are all hydraulic cements – meaning they all have the ability to solidify under water. They are **Portland cement; mortar cement; and masonry cement.** When making mortar, any of the three can be used alone. Portland cement can also be mixed with either masonry cement or mortar cement as the cementitious component of the mortar. The photo shows a pallet of sacks of cementitious material.





*Fundamentals of Masonry – Part A*  
*A SunCam online continuing education course*

**Portland cement** is a particular kind of cement that is consistent throughout the country. All manufacturers make the same kinds of Portland cements. There are eight different Portland cements, but only three are recommended for use in masonry mortars – Type I; Type II; and Type III.

When using only Portland cement in masonry mortars, lime must be added to the mix as a separate, stand-alone, ingredient. If Portland cement is used in conjunction with masonry cement or with mortar cement to make masonry mortar, the lime is included as an ingredient of the masonry cement or mortar cement and, therefore lime is not added as a separate, stand alone ingredient.

**Mortar cement and masonry cement** are blends of Portland cement or other hydraulic cements; plus plasticizing materials; plus other added materials. Plasticizing materials can include limestone, hydrated lime, or hydraulic lime. The other added materials, called **admixtures**, can influence one or more properties of the mortar such as workability, durability, water retention, and setting time.

Mortar cements, as well as masonry cements, are each proprietary, meaning that each manufacturer can make a slightly different blend – and they are not required to tell what ingredients are included in their mix. The various blends depend on the manufacturer, the climate conditions where the mortar will be used, and the local construction practices. They are not consistent across the country.

**Mortar cements** are classified as Type M, Type S, and Type N based on upper and lower limits of the air content of each of the Types.

**Masonry cements** are widely used because of their convenience and workability. They too are classified as Type M, Type S, and Type N according to different upper and lower air contents.

Mortars made with mortar cement and mortars made with Portland cement-lime are considered similar in the building codes. Mortars made with masonry cement are not as strong in flexural tension.

**(3) Sand**, an inert filler material, should be clean, sharp (angular grain, not round), uniformly graded, and free from any harmful materials such as organic matter, salts, etc. The sand must be properly graded to produce a smooth and uniform mortar. Natural sands are most commonly used, but manufactured sands can also be used when making mortar. Sand is a neutral ingredient when making different Types of mortar. Simply stated, sand from a single pile can be used to make all Types of mortar.



*Fundamentals of Masonry – Part A*  
*A SunCam online continuing education course*

(4) **Water** should be clean, potable, and free from deleterious acids, alkalis or organic matter. That's about it for water. Water from a single barrel can be used to make all Types of mortar.

### Mixing Mortar

Most mortar is often mixed on the job site in a portable mixer. To maintain consistency in the mortar during the project, careful control of the mixing and of the amount of materials should be maintained. The materials should be mixed in the same proportions every time, and they should be mixed in the same sequence every time. The photo shows a pile of sand to be used for mixing with a cementitious material and water. The white bag is pre-mixed mortar. It contains the proper mixture of cementitious material and sand. Just add water.



### Proportions of Dry Ingredients

The different Types of mortar can be made using the proper proportions – by volume – of the four main ingredients – cement, lime, sand, and water. Since the dry materials must be carefully and consistently measured and combined, the following table gives the volumetric proportions of the cementitious materials and sand. The table can be converted to weight using the following weight per cubic foot conversions:

- |                   |                                   |
|-------------------|-----------------------------------|
| • Portland cement | 94 lb = 1 bag = 1 cubic foot      |
| • Masonry cements | varies, use weight printed on bag |
| • Mortar cements  | varies, use weight printed on bag |
| • Hydrated lime   | 40 lb = 1 cubic foot              |
| • Sand, loose     | 80 lb of dry sand = 1 cubic foot  |

### Typical Properties of Mortar

The mason is the one in charge of **fresh mortar**. One of his main concerns, after getting the proportions of the mix correct, is how easily it can be spread with a trowel – how stiff it is. This property is known as **workability** and is controlled by the amount of water in the mix. Perhaps an oversimplification, but there certainly is also a lot of truth to the statement, “**Good mortar is what the mason says is good mortar**”.



*Fundamentals of Masonry – Part A*  
*A SunCam online continuing education course*

The two photos show first, a **hod carrier** (mason’s helper) with his empty 5 gallon bucket – which was just previously emptied of fresh mortar – and, second, a square board with a fresh batch of mortar delivered by the hod carrier – a “mortar board”. The caps worn at graduations may have been a spin-off of the craftsman’s square board with mortar. Nice.



The last photo shows the mason spreading the fresh mortar in preparation for setting the next course of blocks. Notice the uniformity of the mortar on the block – a mark of a craftsman.

**Colored mortar** can heighten an already architecturally pleasing structure. Colored mortars can be made with colored aggregate or with pigments added to the mortar mix. If pigments are used, be sure they conform to the ASTM specifications.

### **Mortar Joints**

**Mortar joints** are necessary in masonry construction for more than just holding the units together. In fact, mortar joints have **four main purposes**. Mortar joints:

1. Bond the masonry units together while at the same time sealing the joints between the units
2. Make up for all the slight variations in the sizes, or defects, of the masonry units
3. Bond the masonry units to any reinforcement placed in the joints to provide added strength
4. Can add interest to masonry walls by creating patterns, shadows, or colored lines.

The mortar joints between brick and block vary in thickness from ¼” to ½”. **Mortar joints 3/8-inch thick are the norm.**



*Fundamentals of Masonry – Part A*  
*A SunCam online continuing education course*

A typical masonry wall surface includes less than 10% mortar in the form of joints. Yet these mortar joints account for most of the water damage that occurs in a masonry wall. By selecting the correct mortar joint for the conditions, most water damage can be prevented, or at least reduced.

Mortar joints can have different finishes depending on where they are located. For example, mortar joints inside of a building wall are not subject to high winds and rain and don't have to be as "tight" as joints exposed to the weather, say, on the coast of Maine.

There are two types of mortar joints – two classes; tooled joints and troweled joints. A **tooled joint** is a mortar joint where the excess mortar is cut off – struck – with a swipe of the trowel, allowed to set for a short period of time – long enough for the mortar to become thumb-print hard – and is then finished with a jointing tool. A jointing tool is a specially shaped tool that compresses the mortar into the joint, while also shaping the mortar in the joint.



A **troweled joint** is a mortar joint where the excess mortar is struck with a trowel and then immediately finished with the trowel. Troweled joints can be finished in different shapes also.

The photo shows some typical masons tools. In the upper left is a brush and in the lower right is his trowel. The two tools in the center are jointing tools. The "long" one is for long continuous horizontal joints and the short, red handled one, is for the short vertical joints. The short one actually has two jointing tools – one for 3/8 inch joints and the other for 1/2 inch joints.

Mortar joints exposed to harsh weather conditions should be compacted and sealed in the space between the masonry units. And, certain joints should not be used where the conditions may include high winds, rain, and freeze and thaw cycles.

Here are some standard joints that are used in masonry construction today, with both clay and concrete units.

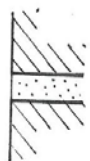

**Rough Cut or Flush Joint.** Troweled joint. This joint is simply struck with the trowel and considered finished. One pass with the trowel – in any direction – is all that it takes. It is the simplest joint a mason can make. This is an un-compacted joint with a small hairline crack where the mortar is pulled away from the joint with the cutting action of the trowel. This joint is not watertight.



## Fundamentals of Masonry – Part A

### A SunCam online continuing education course

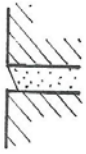

**Struck Joint.** Troweled joint. This common joint is often made on the inside portion of a wall, out of the weather. It also is not watertight. There is some compaction of the mortar however water will accumulate on the small ledge.

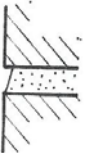

**Weathered Joint.** Troweled joint. This joint is a bit more difficult to make because the mason must work it from underneath the joint. But it is the best of the troweled joints because it is slightly compacted and sheds water nicely.



**Concave Joint.** Tooled joint. The concave mortar joint is the standard joint in masonry construction. It is used unless the type of joint is specified otherwise. This joint is also the most effective joint at resisting the penetration of water through a joint in areas where heavy rains and high winds occur – in severe weathering conditions.

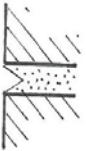

**V-Shaped Joint.** Tooled joint. Identical to the concave joint except a different shaped tool is used to finish the joint. It too resists water penetration.



**Grapevine Joint.** Tooled joint. It is similar to the concave and V-shaped joints except not quite as tightly compacted. Resists water penetration.

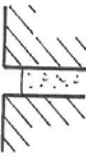

**Raked Joint.** Tooled joint. In this joint, the mortar is “raked” out of the joint while it is still soft. Even though it is a tooled joint, and some compaction can occur, it is not suitable for use in severe weathering conditions like wind, rain, and freeze – thaw cycles because of the ledge. This joint produces dramatic shadows and also darkens the overall image of the wall.

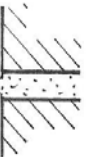

**Beaded Joint.** Tooled joint. In this joint, the mortar is allowed to extend beyond the face of the masonry, producing an interesting effect. It is not a good joint for use in extreme weathering conditions because the water will accumulate on the protruding mortar.

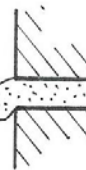

**Squeezed Joint.** This joint is not struck or finished with a trowel or tool. The mortar is just left hanging after a bit of it has been squeezed out of the joint. This joint produces a very dramatic visual effect and was quite popular in the 1970's and 80's. Besides not being water resistant, the squeezed mortar tended to get broken off after several years, producing an unattractive, shoddy, and worn out look.



*Fundamentals of Masonry – Part A*  
*A SunCam online continuing education course*

## **Bond**

In masonry the word “bond” has three meanings.

1. It means the particular arrangement of the units to provide structural strength, stability or a certain visual effect, which can be striking visually, that is created by laying the units in a certain pattern:
2. It means the physical adhesion or mechanical interlock between masonry units, and between the units, mortar, grout and reinforcement;
3. It means to connect wythes or masonry units to form a solid, continuous whole.

## **Bond Patterns**

In this section we will discuss bond as the pattern that units are laid in a wall. Bond patterns are formed in several ways and there are almost an endless number of patterns that can be created – limited only by the creativity of the designer or craftsman. Bond patterns can be created by varying the orientation of the bricks in a wall and the staggering of the head joints vertically in a wall. Bond patterns are also created by using units of different lengths and/or different heights in the same wall. And they can be created by using units of different colors or finishes in the same wall. This last method can create some either subtle or very striking bond patterns.

Bond patterns have evolved over the centuries. Some bond patterns are almost universally known and have names that are more or less standard. And, even though some of the bond names sound peculiar, remember that they all have been developed over time and in different cultures. However, when specifying a particular bond pattern, be sure to fully describe the pattern with both words and drawings to make sure the mason understands what is required.

A continuous horizontal row of bricks or blocks in a wall is called a **course**. Courses are counted vertically. The horizontal joint between units in adjacent courses is called the **bed joint**. The vertical joint between bricks and blocks in a course is called the **head joint**.

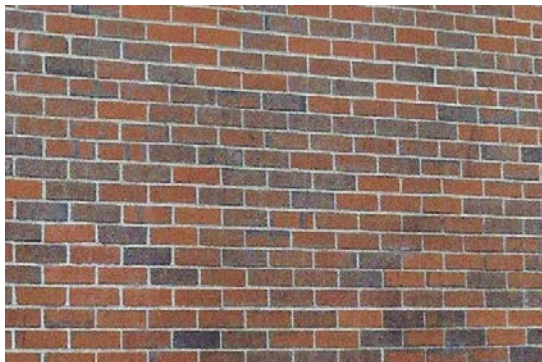

### **Running Bond**

By far, the most common bond pattern in masonry wall construction is called running bond, also known as half bond. This is the simplest of the bond patterns and consists of all stretchers with the head joints of alternate courses aligned vertically and centered on the bricks or blocks in the courses above and below. Of course, the bed joints are continuous along the entire wall.



*Fundamentals of Masonry – Part A*  
A SunCam online continuing education course

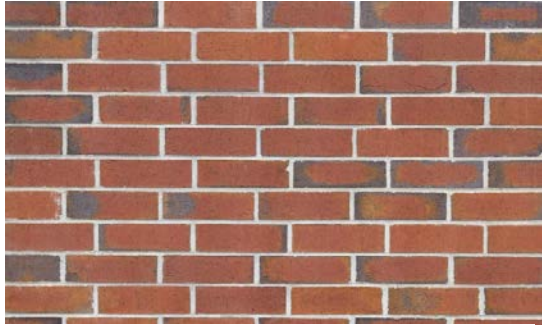

**One-Third Running Bond – Patterned Offset**

A simple variation on the running bond is the one-third running bond. In this case, the head joints are aligned along the third point of the bricks or blocks in the adjacent courses. When the head joints align vertically in alternate courses, as in this photo, it's known as a **patterned offset**.

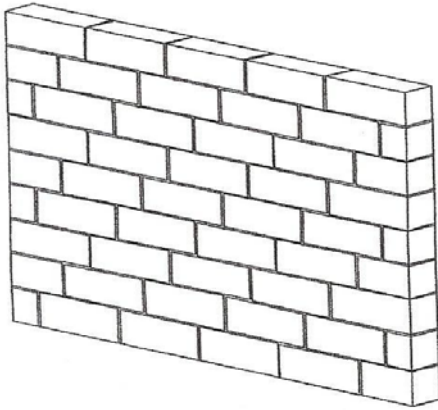

**One-third Running Bond – Staggered Offset**

Another variation on the running bond is the one-third running bond where the head joints of the bricks or blocks are aligned at the third point. When the vertical head joints are aligned every third course, as shown in the drawing, it is called a **staggered offset**.

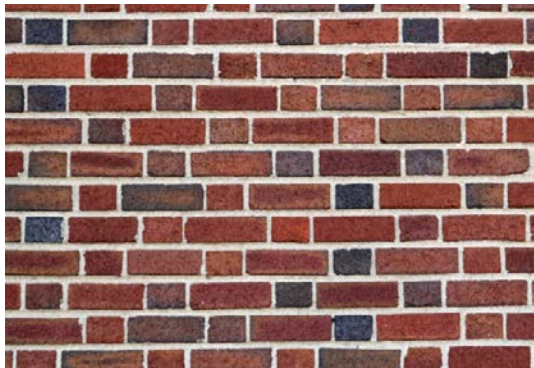

**Flemish Bond**

Flemish bond is a pattern where every course of brick contains alternate stretchers and headers. The headers are centered on the stretchers in the adjoining course. When the headers are not used for structural purposes, the header bricks are half brick. A half brick is called a “**clipped**” header or “**snap**” header, and is created by the mason in the field by simply breaking a single brick in half with a sharp blow from his trowel.

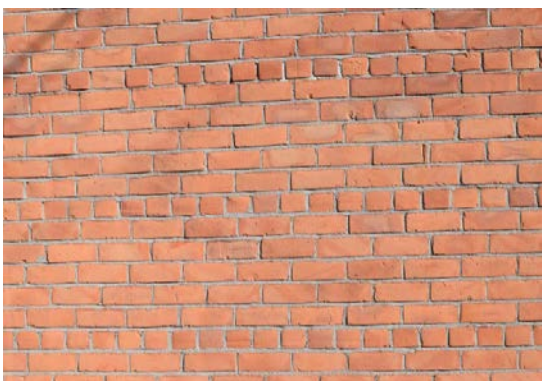

**Common Bond**

Common bond is also called **American** bond. In this pattern, the running bond pattern includes a course of full length headers at regular intervals. Usually the header courses are at every sixth course as shown here. However, sometimes the 5<sup>th</sup> or 7<sup>th</sup> course is used. Look for this pattern on old masonry buildings such as this one. The headers in these old buildings are structural units that join two parallel walls together (two wythes).





*Fundamentals of Masonry – Part A*  
*A SunCam online continuing education course*

In the previous photo, notice the larger header in the top header course shown – near the left side. Why is it a different size? Did the mason make a mistake? Don't know. Maybe. Perhaps the mason made a few header joints too tight and needed to “make up” to get to the proper spacing; or, maybe there was a problem in the second wythe that we can't see; or, it could be that the larger header was simply the next brick from the header supply stack. In any case, it is still a perfectly functioning masonry wall as evidenced by the fact that it has performed well for the past century and a half. By the way, it's the fourth full brick from the left.

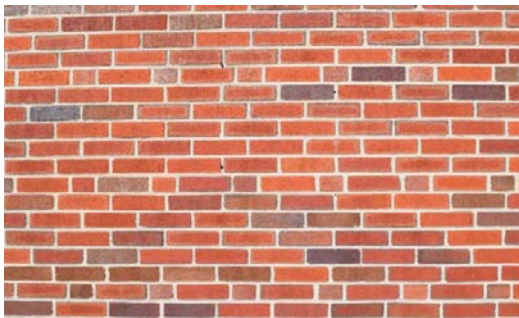

**Common Bond with Flemish Headers**

Another common bond pattern except in this instance, the header course is composed of a Flemish header pattern every 6<sup>th</sup> row (alternate stretchers and headers).

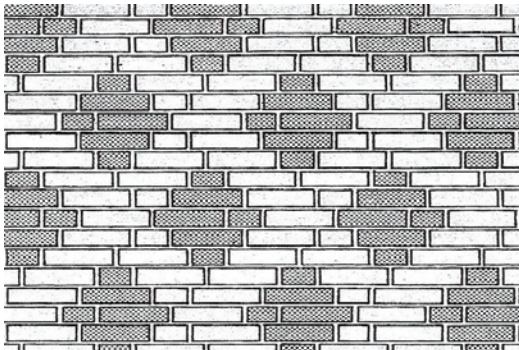

**Double Stretcher Garden Wall Bond**

Variations in Flemish bond (headers and stretchers in every course) are created by placing more stretchers between each header in each course. If two stretchers are regularly placed between each header, the bond pattern is known as Double Stretcher Garden Wall Bond. Two shades or colors of brick make a pleasing pattern.

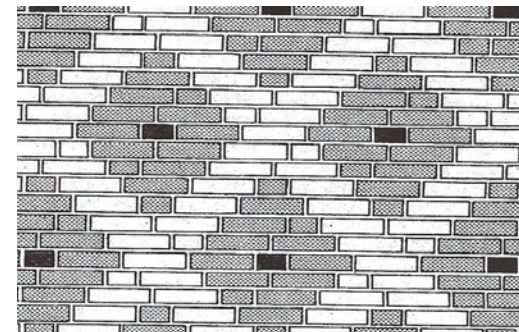

**Garden Wall Bond**

If three stretchers are regularly laid between each header, the pattern is known as Garden Wall Bond. Using three shades or colors of brick makes the pattern “pop”. Additional variations include four stretchers and five stretchers regularly between each header in a course.



*Fundamentals of Masonry – Part A*  
*A SunCam online continuing education course*



**Stack Bond**

Stack bond is also called **block** bond. In this pattern, all head joints align vertically. Because there is no overlapping of head joints, this pattern has slightly less structural integrity than other bond patterns. Therefore, some form of steel reinforcing is usually used in the horizontal mortar joints – in the bed joints.

**Other Bonds**



Other bond patterns can be made by using different colored bricks, blocks, and/or mortar joints, and also by using unique arrangements of brick placement in a wall. Be on the look-out for different and interesting bond patterns as you drive and walk around your town. It's fun to spot them.

**Running Bond with Two Colors**

An attractive bond pattern is made on this ticket sales booth at the entrance of a high school football stadium. It is simply a running bond pattern using two different colored bricks.



**Running Bond with Three Colors**

Here is a totally different look using, again, a simple running bond pattern with three different colored bricks.

This next series of three photos show an intricate pattern of brick laid in a striking bond pattern – actually almost a mural. Imagine the creativity and skill of the mason to consistently place each brick in its proper position as the courses are laid up the wall. The result is a stunning diamond pattern with interesting and varied borders. Notice that the brick colors vary only because of the manufacturing process – they are their natural colors placed randomly in the wall. The different colors are not “selected” and placed precisely as in the previous two colored brick patterns. Still, the diamond pattern presents itself to the viewing public – at least to those who choose to look. Will you find something as interesting near where you live and work?



*Fundamentals of Masonry – Part A*  
*A SunCam online continuing education course*

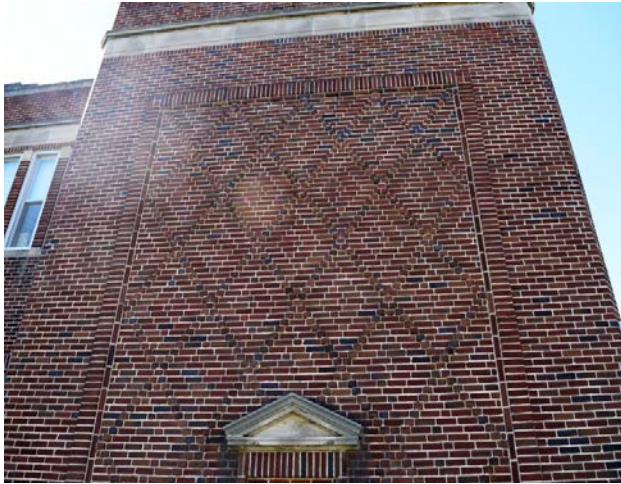

The diamond motif is bordered on each side by stretchers placed in stack bond with a vertical row of soldiers on the side toward the pattern. The top of the diamond patterned area is defined by a course of stretchers with a top course of soldiers. And the remainder of the wall – outside of the borders – is running bond.

The bottom border of the diamond design is – from the foundation up – a course of stretchers, two courses of diagonal bricks, another course of stretchers, and finished with a course of soldiers.



The diamond pattern starts immediately above the soldiers with a course of stretchers and appropriately placed snap headers. The diagonals in the 2<sup>nd</sup> and 3<sup>rd</sup> courses from the bottom (under the diamond pattern) are particularly time consuming to lay because both ends of each brick are individually cut on a bevel.

The “door” feature in the lower center was never actually a door. It is an accent placed in the wall. It is composed of snap headers in a stack bond pattern in the field, recessed inside the two sides of protruding headers in stack bond. The top is one course of stretchers with a course of slightly protruding soldiers above. A precast concrete highlight tops off the door feature.

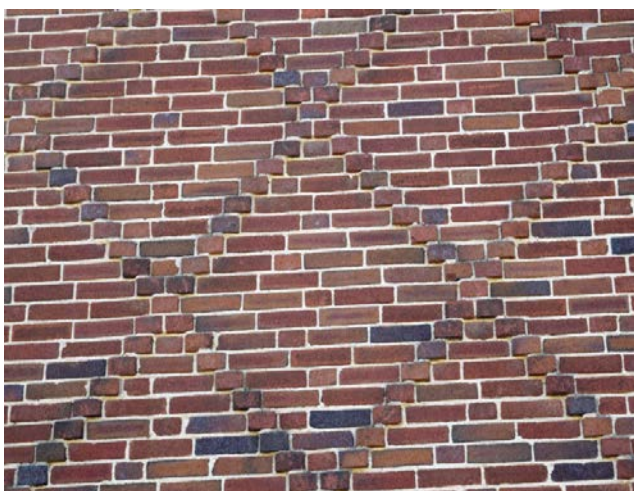

The diamond patterns are created using only stretchers and snap headers placed in a very precise and regular pattern. As you carefully study the order of the bricks, you will begin to see very clearly the pattern used to create the diagonals. It takes a clever, creative, patient, and skilled mason to do this kind of work.



*Fundamentals of Masonry – Part A*  
*A SunCam online continuing education course*

### **Wall Construction – the Basics**

Building walls using masonry construction is simple but not easy. It is simple because, in principle, a masonry wall consists of simply stacking one unit on top of another and holding them in place with mortar. It is not easy because of the many very important details of the construction that must be done properly to insure the wall performs as expected – which is to resist applied loads (wind, roof and floors, snow, hurricanes and earthquakes), enclose space, and provide a comfortable enclosed environment. Of course, there are many other uses of masonry as well – retaining walls, fireplaces, drives and walks, etc., but our focus here is on the fundamentals of typical walls used in masonry buildings.

The structural design of masonry walls is an area separate and different from our discussion in this course because, aside from structure design errors, 90% of all masonry building problems are directly related to water. Masonry construction is NOT waterproof. Our concern here, then, is the resistance of water penetration through masonry walls. Water in the form of rain and snow wet the masonry, and freezing and thawing can cause cracking, spalling, and eventually disintegration. Water vapor is always in the air and moves from high humidity areas to low humidity areas. Since water cannot be eliminated, movement through the wall must be controlled.

In masonry walls, wind driven rain is the primary source of water penetration. Under normal conditions, it is nearly impossible to keep a heavy wind-driven rain from penetrating a single wythe of brickwork, regardless of the quality of materials or the degree of workmanship used. A 10 mph wind with rain can drive water into a properly constructed masonry wall up to 1 inch. A 30 mph wind with rain can drive water into a masonry wall up to 3 inches. The water will be forced through any path available through the wall: through permeable masonry units; through mortar joints; and through cracks or other openings in the wall. If the wall is poorly or improperly built, the water can actually flow through a masonry wall. If water penetration can be limited, and controlled, for all practical purposes the interior of the wall will remain dry.

Up until the 1930's, it was common to resist water penetration and to support loads simply by making the masonry walls massively thick. These walls ranged in thicknesses from 12" up to 6 feet thick of clay masonry bricks. If you notice an old brick building in your area being renovated, pay close attention to the thickness of any exposed walls. Chances are they will be at least three wythes thick, each wythe tied to the adjacent wythe with headers. We rarely see brick walls constructed like that today because the labor to construct such walls is cost prohibitive – it takes a long time to construct three wythes, or more, of interlocking brick masonry wall. In the 1930's, building codes recognized that properly designed and built cavity walls, as well as solid masonry walls, can prevent water from passing through the wall. Cavity wall construction soon became one of the most popular walls built.



## Fundamentals of Masonry – Part A

### A SunCam online continuing education course

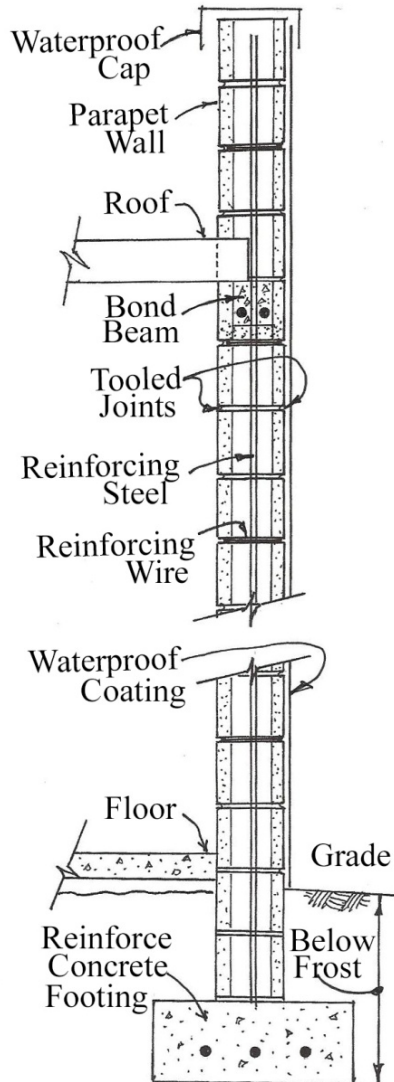

Today, probably the two most common types of masonry walls are the **single wythe concrete block wall** and the **brick veneer cavity wall**. We will look at these walls in their simplest form.

### Single Wythe Concrete Block Wall

The single wythe concrete block wall, sometimes called a barrier wall, is the most economical masonry wall to build. It is typically made with standard 8" or 10" CMU's, is a solid wall that can resist the penetration of water, and can be built to carry loads as well. This wall usually requires a protective waterproof coating, especially if the masonry units are textured and fairly permeable. The walls are extensively used in all parts of the country as storage facilities, and in big box stores such as Home Depot, Costco, Wal-Mart, and others.

The procedure for the construction of a concrete block wall is fairly straight forward. A foundation of reinforced concrete is placed on compacted soil at a depth below the anticipated frost line. Standard CMU's are then laid up, typically in one of the running bond patterns, and finished with a tooled joint, usually concave. Every few courses a layer of steel reinforcing wire is placed in the bed joint. Vertical and horizontal reinforcing steel is placed in the cores of the block and grouted into place at prescribed locations. The corners of the walls are interlocked with the blocks from the adjacent wall to add stability. And the exterior is waterproofed using one of the many products available for that purpose.

A cross section of a wall is shown. Notice the symbol for the cross section of a concrete block. There are many variations of this symbol, but this is typical. Also notice a few other details that are typical on other cross-section drawings – like the line representing the waterproof coating, the symbol for reinforcing wire in the bed joint of the block, the cross hatching representing the soil of the finish grade, the markings representing concrete (triangles and dots), and the small solid circles representing reinforcing steel bars in the concrete footing and bond beam.



## Fundamentals of Masonry – Part A

### A SunCam online continuing education course

The wall is reinforced to resist the anticipated loads. Depending on where in the country the wall is located, the loads, for example, may include high winds, heavy snows, and/or earthquakes. Reinforcing steel bars are placed vertically at intervals within the cores of the block and are also placed horizontally in bond beams within special shaped blocks. Horizontal wire reinforcement consists of many sizes of truss or rectangular shaped wire frames (photos below) placed at intervals in the bed joints.

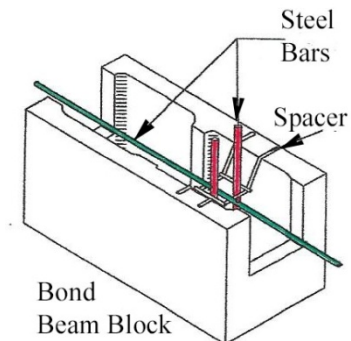

The outside of the wall is protected against water by applying a waterproof coating, often high quality paint. The inside of the building can be insulated against thermal extremes by filling the block cores with insulation (one example shown in photo), or an interior finish such as wood or steel stud furring and drywall can be applied to accommodate insulation (as well as electrical and other utilities). The parapet wall is an extension of the wall above the roof line and its primary function is to keep the roof water from washing down the sides of the masonry. It is important to have a water proof cap on top of the parapet to prevent water from entering the cells of the block.



### Brick Veneer Cavity Wall

A brick veneer cavity wall is an exterior clay brick masonry veneer wall attached to and supported by a back-up wall. The two walls of the cavity wall have a continuous air space between them. Since the brick veneer is not waterproof, the goal of the cavity wall system is to interrupt the path of moisture through the porous materials within the wall. And this system does just that very well. The tricky thing about brick veneer cavity walls is that because a 4" thick clay brick masonry wall is not waterproof, accommodations must be made to handle the water



## Fundamentals of Masonry – Part A

### A SunCam online continuing education course

that does penetrate the exterior brick veneer. The details necessary to accomplish that must be done correctly and properly to keep the back-up wall dry.

The cavity wall has replaced the multi-wythe solid brick walls in masonry construction, again, because of labor cost savings and also because the veneer walls are much more energy efficient, are capable of containing plumbing, electrical, HVAC ducts, and other utilities, as well as insulation, and, they provide an appealing looking exterior. Nearly all “brick houses” built today are really wood framed houses with a brick veneer around the exterior of the home.

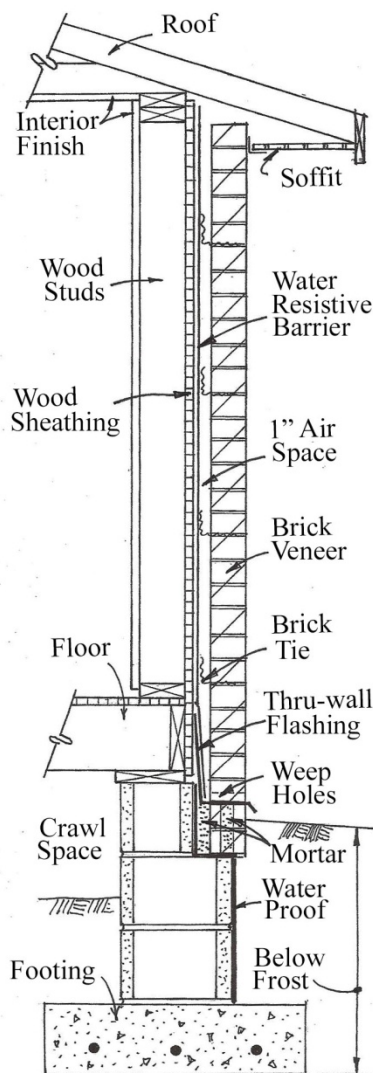

The exterior veneer is a nonstructural facing of brick. It does not add to the strength of the wall. The back-up wall to which the brick veneers are attached, according to the building code, “...shall consist of concrete, masonry, steel framing, or wood framing.”

Typically, moisture passes through the brick veneer and condenses on the back side of the exterior wall. It then drains down the backside of the brick and exits out the bottom of the wall. Air then circulates within the cavity to dry out the space between the walls. This entails many more, very important, details that must be done correctly to prevent moisture from entering the back-up wall and the interior of the home.

The cross section drawing shows a typical wood framed building with a clay brick masonry veneer with both a concrete block and a wood frame backup wall. Looking at the inside of the building from the bottom of the cross section, see the reinforced concrete footing set below frost line; a crawl space under the interior floor system; the foundation wall consisting of 6 inch CMU’s set upon 10 inch CMU’s with the 4” offset supporting the brick veneer above; wood wall framing from the floor system to the roof system showing floor joists, wood wall studs with wood sheathing, roof trusses, and drywall interior.

Working down from the top on the exterior of the wall we see the soffit with brick veneer extended up and into the soffit overhang to allow air to rise in the space between the back-up wall and the veneer.



*Fundamentals of Masonry – Part A*  
*A SunCam online continuing education course*



The two photos above show a veneer wall of stone (rather than clay brick) extending up behind the framing for the yet to be built soffit (left photo), and the nearly completed soffit (right photo).

Continuing down the cross section notice a line representing a water-resistive barrier attached to the wood sheathing; a 1” air space; the brick veneer (notice the detailing representing the clay brick masonry); corrugated metal brick ties to attach the veneer to the backup wall; thru-wall flashing that extends completely through the brick veneer and attaches up the back-up wall (notice that the water-resistive barrier laps over the thru-wall flashing); weep holes in regularly spaced head joints of the brick immediately above the thru-wall flashing; mortar filled brick cores and collar joint; and foundation wall waterproofing material extending from the wood to the footing.

This detailing allows moisture to pass through the exterior veneer wall, whether it is wind driven rain or water vapor, condense into water droplets on the backside of the wall, and drain down the backside of the veneer, and out the bottom of the wall through weep holes to the exterior.

Outside air is also allowed into the wall cavity through the weep holes and travel up the cavity and out the top of the wall into the ventilated soffit area allowing the cavity of the wall to dry out. The water-resistive barrier and thru-wall flashing provides the water resistant barrier that keeps the inside of the building dry and free from moisture.



The photo shows attaching the final metal strip to the top of the fully adhered rubber membrane (the green material). The edge of the stainless steel sheet metal thru-wall flashing with drip edge is visible under the membrane. The assembly sits atop a masonry foundation wall with mortar filled cores and collar joint to support the sheet metal flashing and veneer wall. The DuPont™ Tyvek® HomeWrap® water-resistive barrier will be lapped





*Fundamentals of Masonry – Part A*  
*A SunCam online continuing education course*

over the rubber membrane, which is lapped over the thru-wall flashing, to insure water drains properly down the backside of the veneer to the weep holes with virtually no chance of reaching the wood sheathing on the back-up wall.

### **Thru-wall flashing**

There are many thru-wall flashing materials available on the market today. Flashings may include stainless steel sheet metal, copper sheeting, self adhering rubberized bituthene membranes, EDPM, and others. Always install thru-wall flashings and weeps at least 4” above finished grade. The brick cores and open collar joint should be filled with mortar to prevent water from accumulating and freeze spalling below grade, and to provide a solid surface to support the base flashing and weeps. Also the thru-wall flashing should extend up a minimum of 8” and lap under the air/moisture barrier.

### **Water-resistive barrier**

Beginning somewhere around the 1930’s, when the building codes finally approved cavity walls, most building codes specified what was commonly called “tar paper” to be attached to the wood sheathing. The material was then known as “15 pound felt”, which meant that 100 ft<sup>2</sup> of felt paper was impregnated with 15 pounds of bituminous material. Today, the material is known as “No. 15 asphalt felt” because the 100 ft<sup>2</sup> of felt paper is impregnated with something less than 15 pounds of asphalt material.



The only water-resistive barrier specifically approved in the building code today is No. 15 asphalt felt. The International Building Code still specifies that “*A minimum of one layer of No. 15 asphalt felt, complying with ASTM D 226 for Type 1 felt, shall be attached to the sheathing ...*”. The building code also states that “*Materials not prescribed herein shall be permitted, provided that any such alternative has been approved.*”

An issue with the felt paper is that it will absorb moisture, and, over time, moisture will cause it to deteriorate. There are several alternatives to the felt paper (that are not specified in the building codes) that have been developed over the years that are much more convenient to install, and perform better than the felt paper. And, many of these new products have been approved. One such product is DuPont™ Tyvek® HomeWrap®, which is a spun plastic, non-perforated, non woven product with microscopic pores that are so small that air and bulk water (droplets) have a difficult time passing through. Think of the cotton candy machine at the local summer festival when thinking of the spun wrap being manufactured.



*Fundamentals of Masonry – Part A*  
A SunCam online continuing education course

There are many other products on the market claiming to do something similar. However, some of them are simply perforated sheeting, which means that for them to breathe, holes have been punched in the material. Before you start a project, be sure to get product performance specifications. Waterproof membranes, PVC, plastic sheeting or any other wind, UV, or freeze/thaw damage prone materials should not be used.

### Wall ties

Wall ties are corrugated metal strips about 8 inches long by about 1 inch wide that are nailed vertically to the wood sheathing and bent over creating a horizontal leg that lays in the bed joint of the masonry veneer wall. These ties are placed regularly throughout the masonry veneer wall to hold the veneer in a vertical plane. Without them, the thin masonry veneer wall would buckle and literally fall down.



### Weep holes

Along the top of the horizontal leg of the thru-wall flashing there are weep holes spaced regularly along the wall. These weep holes are simply small openings in the head joint of the bottom row of brick to allow water that entered the cavity through the veneer wall to drain out of the wall. Weep holes may include open head joints, a piece of rope, a plastic tube, or one of countless louvered, vented, or drainage screens available in the market.



A layer of p-fill or drainage mesh placed in the space between the back of the brick and the flashing up to the depth of the weep hole will prevent mortar droppings in the cavity

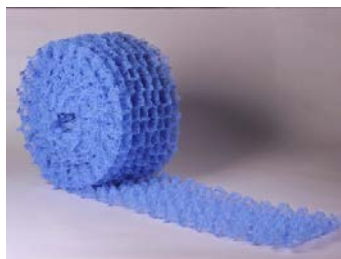



## Fundamentals of Masonry – Part A

### A SunCam online continuing education course

from clogging the drainage system. Mortar Break from Advanced Building Products, Inc., [www.advancedflashing.com](http://www.advancedflashing.com), is one product. (Used with permission).



After the water has drained, fresh outdoor air enters the weep hole, travels upward in the 1 inch cavity and exits out the top of the wall. The air rises in the cavity because typically the cavity is warmer than the exterior of the brick or the air outside. Sun shining on a masonry wall will heat it up nicely. To help maintain a consistent width air space, and to insure that no mortar droppings plug the space between the walls, mesh may be placed over the entire wall. The photo shows rope weeps in place over the wall flashing and behind the yellow fiber drainage/spacer mesh, and corrugated metal wall ties attached, ready to bend down into the horizontal mortar joints. The ties are staggered randomly in the photo because the veneer that will be applied will be irregular stone rather than uniformly sized bricks.

If any of these details are not properly done, moisture will get into the wood framed wall causing mold and mildew with possibly devastating results. The following course – Fundamentals of Masonry - Part B – will show some examples of what can result from improperly constructed masonry veneer cavity walls.

The three photos show adhered rubber over copper sheet metal thru-wall flashing, and the beginning of a low brick cavity wall with rope weeps enclosing a third floor exterior deck.





*Fundamentals of Masonry – Part A*  
*A SunCam online continuing education course*

### Typical Masonry Corner



Two masonry walls coming together at a corner are “interlocked” to provide structural integrity to both walls. The block, brick, or other masonry material has every other unit overlapping the unit in the other wall as shown in the left photo (and in the previous “soffit” photos).



If a brick wall corners with a block wall, they will still interlock. The photo at the left shows a historic building built in 1865 with a brick and block corner. The red brick wall is a three wythe red clay brick wall. The yellow wall is also three wythes thick except that the two interior wythes are made of red clay brick and the exterior wythe is made of a yellow clay the size of a block with the thickness of a brick.

### Openings in Masonry Walls

There are many openings in masonry walls including windows, doors, hose bib penetrations, HVAC exhaust vents, electric lighting boxes, etc. All of these openings require flashing details that have some unique characteristics to function properly. And, brick must be supported above these openings. The photo shows an electrical box for a low light fixture on a deck. We will take a look at some more details of openings in the next course.





*Fundamentals of Masonry – Part A*  
*A SunCam online continuing education course*

**Credits (and Where to Learn More)**

A Driving Rain Index, Grimm, C.T., “A Driving Rain Index for Masonry Walls”, *Masonry: Materials Properties and Performances*, ASTM STP 778, J.G. Borchelt, Ed. American Society for Testing and Materials, 1982, pp. 171-177. Used with permission.

A Driving Rain Index Map, Malhotra, Ashok: Brick Veneer Concrete Masonry Unit Backing: Best Practice Guide. CMHC. 1997. Image © RHD Building Science Inc., [www.buildingsciencelabs.com](http://www.buildingsciencelabs.com) Used with permission.

Advanced Building Products, Inc., Specification Bulletin No. 310 – 339, Mortar Break. [Info@advancedflashing.com](mailto:Info@advancedflashing.com) Used with permission.

The Brick Industry Association, Reston Virginia, 22091 (especially the *Technical Notes*). [www.bia.org](http://www.bia.org) Used with permission.

National Concrete Masonry Association (especially the *NCMA – TEK* notes) [www.ncma.org](http://www.ncma.org) Used with permission.

Colonial Williamsburg, Williamsburg, VA 23185, [www.colonialwilliamsburg.com](http://www.colonialwilliamsburg.com)