



A SunCam online continuing education course

Fundamentals of Clarifier Performance Monitoring and Control

by

Nikolay Voutchkov, PE, BCEE



Fundamentals of Clarifier Performance Monitoring and Control

A SunCam online continuing education course

1. Introduction

Primary and secondary clarifiers are a separate but integral part of every conventional wastewater treatment plant (WWTP). The primary clarifiers are located downstream of the plant bar screens and grit chambers to separate settleable solids from the raw wastewater influent, while the secondary clarifiers are constructed downstream of the biological treatment facility (activated sludge aeration basins or trickling filters) to separate the treated wastewater from the biological mass used for treatment. The two types of clarifiers have similar configurations and utilize gravity for separation of solids from the feed water entering the clarifiers.

Solids that settle to the bottom of the clarifiers are usually scraped to one end (in rectangular clarifiers – see Figure 1) or to the middle (in circular clarifiers – see Figure 2) into a sludge collection hopper. From the hopper, the solids are pumped to the sludge handling or sludge disposal system. Sludge handling and sludge disposal systems vary from plant to plant and can include sludge digestion, vacuum filtration, incineration, land disposal, lagoons, and burial.

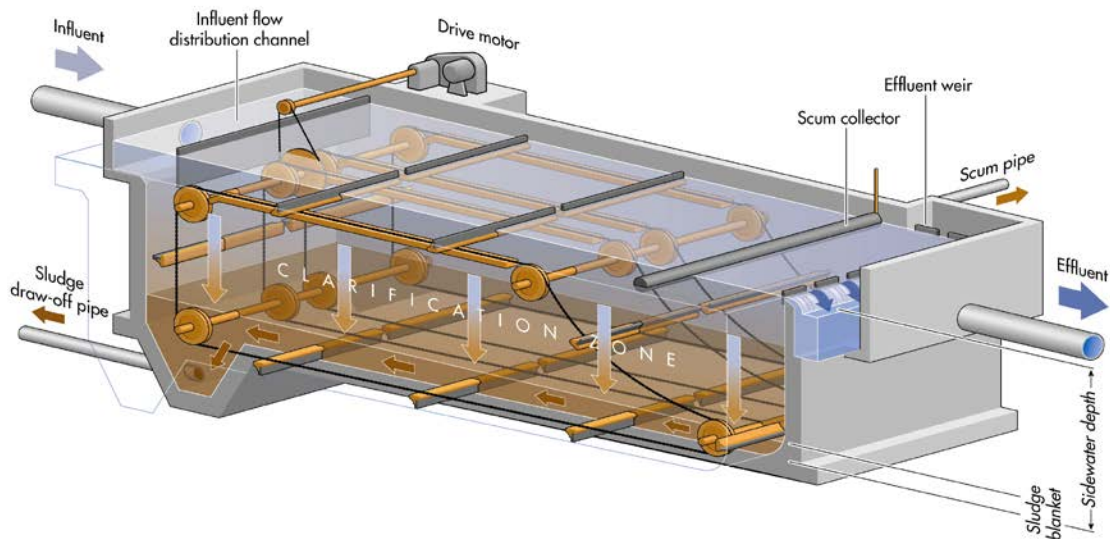

Figure 1 – Rectangular Clarifier

Fundamentals of Clarifier Performance Monitoring and Control

A SunCam online continuing education course

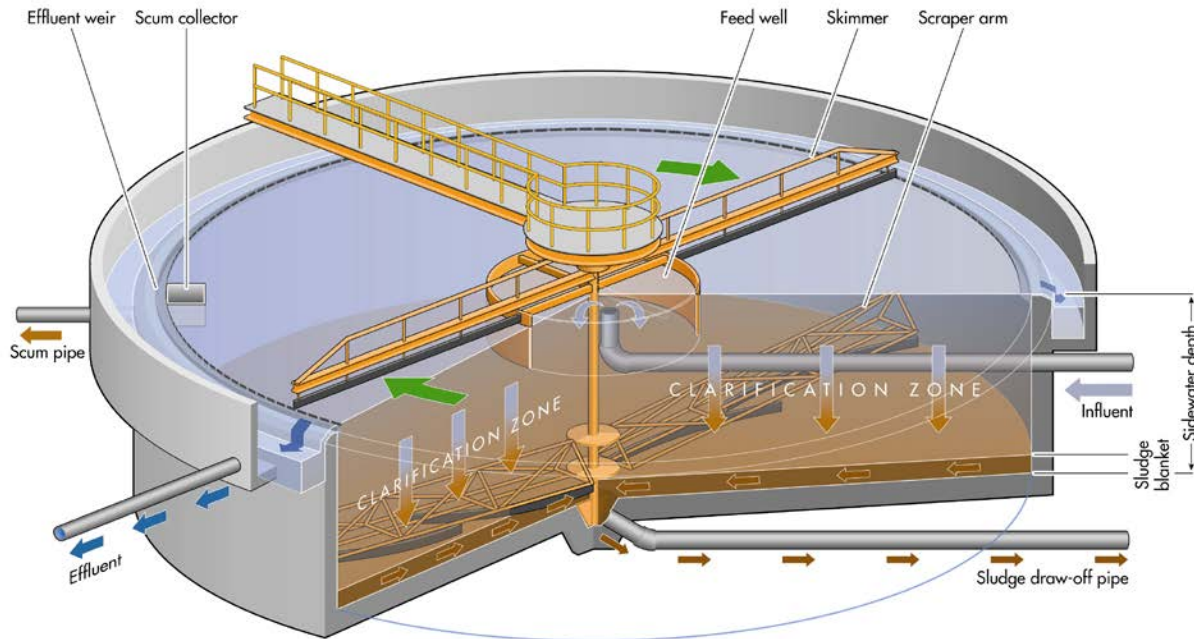

Figure 2 – Circular Clarifier

The most important function of the primary clarifier is to remove as much settleable and floatable material as possible. Removal of organic settleable solids is very important due to their high demand for oxygen (BOD) in receiving waters and subsequent biological treatment units in the treatment plant.

The two main functions of secondary clarifiers are clarification and thickening. Clarification is a solids separation process that results in the removal of the biological flocs from the liquid stream exiting the secondary treatment process. During the following thickening procedure, the sludge particles are conveyed to the bottom and concentrated. A supporting secondary function is to store sludge during peak flow periods. If the clarifier fails in either of these functions, the performance of the biological process will be impacted. Consequently, due to solids carryover, the effluent may not meet the specified discharge limits. The key factors that impact clarifier performance are listed in Table 1.



Fundamentals of Clarifier Performance Monitoring and Control
A SunCam online continuing education course

Table 1 - Factors that Impact Clarifier Performance

Category	Factors
Hydraulic and Load Factors	<ul style="list-style-type: none"> ▪ Wastewater flow (ADWF, PDWF, PWWF) ▪ Surface overflow rate ▪ Solids loading rate ▪ Retention time ▪ Sludge removal rate ▪ Underflow recycle ratio (for secondary clarifiers)
External Physical features	<ul style="list-style-type: none"> ▪ Tank configuration ▪ Surface area ▪ Depth ▪ Flow distribution ▪ Turbulence in conveyance structures
Internal Physical Features	<ul style="list-style-type: none"> ▪ Presence of flocculation zone ▪ Sludge collection mechanism ▪ Inlet arrangement ▪ Weir type, length, and position ▪ Baffling ▪ Hydraulic flow patterns and turbulence ▪ Density and convection currents
Site Conditions	<ul style="list-style-type: none"> ▪ Wind and wave action ▪ Water temperature variation
Influent Quality (for Primary Clarifiers) and Activated Sludge Characteristics (for Secondary Clarifiers)	<ul style="list-style-type: none"> ▪ Plant influent septicity (for primary clarifiers) ▪ MLSS concentration (for secondary clarifiers) ▪ Flocculation, settling, and thickening characteristics ▪ Type of influent screening and grit removal processes (for primary clarifiers) ▪ Type of biological process (for secondary clarifiers)



Fundamentals of Clarifier Performance Monitoring and Control

A SunCam online continuing education course

Whereas all of these are important considerations, flow and sludge characteristics are central to sizing the clarifier. The remaining factors enhance clarifier performance and improve process reliability.

The performance efficiency is affected by the upstream wastewater collection and treatment facilities. It also has a significant impact on downstream biological treatment and solids handling facilities. Therefore, clarifier performance monitoring and control are of critical importance for the successful WWTP operation.

Clarifier process performance monitoring and control takes many forms and can vary between manual and automatic operation of clarifier sludge collection and withdrawal to control of the clarifier's sludge blanket level. Properly designed, installed and maintained instrumentation for clarifier monitoring creates a reliable on-line database for efficient process control and decision-making.

Removal of sludge in a manner that maximizes solids concentration, while minimizing the impact of sludge removal on effluent water quality, is a principal task and goal in clarifier operation. Clarifier sludge concentration has a significant impact on the capacity and performance of the downstream solids handling facilities. Maximizing clarifier sludge concentration typically improves solids handling facility operations and increases their process capacity.

Clarifier underflow sludge concentration pumped from the bottom of the tank can be maximized by appropriate design of the sludge collection and removal systems and, frequent sludge withdrawal coupled with sludge blanket depth level monitoring. In optimal design and operation, sludge should be removed from the clarifiers at the rate of its generation after providing an ample time for sludge thickening to optimal concentration.

If the sludge concentration is reduced significantly during facility operation, the clarifier sludge collection and removal rates can be reduced. If needed, collection and removal can be discontinued until sludge concentration returns to an optimal range. On the other hand, a sludge concentration above optimum, and a steady increase in sludge blanket depth indicate the need to raise sludge collection and withdrawal rates. Such action is necessary to deter a high sludge blanket zone in the clarification section that would ultimately have a negative impact on the clarifier effluent water quality.



Fundamentals of Clarifier Performance Monitoring and Control

A SunCam online continuing education course

Since the sludge generation and withdrawal rates can vary over time due to fluctuations in influent water quality and quantity, frequent or continuous monitoring of the concentration of sludge removed from the clarifiers and clarifier sludge blanket provide an ample indication of the overall clarifier performance.

2. Key Performance Monitoring Parameters

Primary Clarifiers

Primary clarifier performance is typically determined ~~by total~~ by total suspended solids (TSS), biological oxygen demand (BOD), and phosphorus removal efficiency, in addition to the condition of the primary sludge (sludge septicity, concentration, and volume). Primary clarifier performance in terms of effluent TSS, BOD and phosphorus removal efficiencies has a very significant impact on the operation of the downstream biological wastewater treatment system.

Proper primary clarifier sludge collection, removal, and withdrawal are of key importance to maintaining consistently high primary effluent quality and ~~efficient, cost~~ efficient, cost-effective solids handling. If primary clarifier sludge is retained for an excessively long time in the clarifiers, the sludge can turn septic due to high organic content and anaerobic conditions in the sludge blanket.

Sludge septicity is accompanied by the release of malodorous gasses ~~that disturb~~ that disturb the normal sedimentation process as they rise from the tank sludge blanket to the surface. In addition, septic sludge is more corrosive and difficult to pump and dewater. Besides creating conditions for sludge septicity, maintaining a deep sludge blanket in the primary clarifier makes sludge collection and withdrawal more difficult due to compaction and, in extreme conditions, may cause damage to the sludge collection and withdrawal equipment (broken sludge collectors, plugged solids lines, and damaged pumps).

Two widely-accepted practices to avoid primary sludge septicity and its negative effect on clarifier performance are to intermittently employ a sludge blanket or do frequent sludge removal from the clarifier. When not controlled appropriately, continuous sludge withdrawal or over-pumping will result in the conveyance of a very diluted sludge to the downstream solids handling facilities, which would have a negative impact on their performance.

In shallow primary clarifiers (i.e. clarifiers with a sidewater depth of less than 3.66 meters (12 feet)) or clarifiers settling highly septic plant influent (i.e. influent which contains hydrogen sulfite concentration higher than 50 mg/L), continuous sludge withdrawal, although not optimal



Fundamentals of Clarifier Performance Monitoring and Control

A SunCam online continuing education course

for the downstream solids handling facilities, may be necessary to prevent the negative impact of the clarifier blanket on the primary effluent TSS concentration. Under this sludge removal approach, the sludge blanket is relatively thin and the primary sludge concentration is usually between 0.5 and 1% solids.

Full-scale studies of shallow primary circular clarifiers at two large wastewater treatment plants (Albertson and Waltz, 1997) reveal a close adverse correlation between clarifier sludge blanket retention time and total suspended solids removal. The sludge blanket retention time is estimated by dividing the solids mass in the clarifier by the mass rate of the solids removed in the underflow. For simplicity, the solids mass in the clarifiers in this study was determined by assuming that the average sludge blanket concentration in the clarifiers is equal to 50% of the clarifier underflow concentration. The sidewater depth of the studied primary clarifiers at the two plants was 2.74 meters (9 feet) and 3.14 meters (10.3 feet), respectively. The optimum primary clarifier sludge blanket retention time at the studied wastewater treatment plants was found to be 6 to 12 hours and the optimum, and maximum sludge blanket depths to be 0.125 meters (5 inches) and 0.3 meters (12 inches), respectively.

To avoid over-pumping of the diluted sludge and to prevent the negative effects of an excessively deep sludge blanket and associated septicity, primary clarifier sludge blanket and concentration have to be maintained at optimum levels. The optimum primary sludge concentration is usually in a range of 3 to 6%, and the most viable sludge blanket depth is typically between 0.3 and 1.0 meter (1 and 3 feet). The optimum sludge blanket depth would vary seasonally and would change during dry-weather and wet-weather conditions. This optimum sludge blanket depth would also depend on the clarifier overall sidewater depth and solids inventory, and the influent wastewater septicity and strength in terms of BOD and TSS.

At present, most plants' primary clarifier sludge concentration and blanket depth are monitored using manual sample collection and analysis. However, reliable sludge concentration analyzers and blanket level detectors that can withstand the negative environment found in primary clarifiers are commercially available.

Secondary Clarifiers

Secondary clarifier performance has a significant effect on plant effluent water quality; aeration basin mixed liquor suspended solids (MLSS) concentration and performance; and efficiency of plant solids handling facilities. Key secondary clarifier effluent quality monitoring and control parameters for secondary clarifiers are TSS, BOD, ammonia, total nitrogen and total phosphorus concentrations and removal efficiencies.



Fundamentals of Clarifier Performance Monitoring and Control

A SunCam online continuing education course

Besides effluent water quality, there are four key process variables that need to be monitored for efficient and cost effective clarifier solids control:

- (1) the amount of solids retained in the secondary clarifiers, which is determined based on the concentration of the return activated sludge (RAS) and the waste activated sludge (WAS) removed from the clarifiers, and on the clarifier sludge blanket depth/volume
- (2) the amount of solids in the aeration basins, which is determined by measuring the MLSS concentration and the plant influent flowrate
- (3) the activated sludge settleability
- (4) the plant influent flow and waste load, significant fluctuations of which may result in the transfer of large amounts of solids from the clarifiers to the aeration basins, thus causing solids carryover with the secondary clarifier effluent.

Monitoring of Activated Sludge Solids Inventory. The amount of solids retained in the clarifiers can be monitored by frequent manual or automated measurements of the sludge blanket depth and WAS/RAS solids concentration. Monitoring the concentration and volume of the sludge removed from the secondary clarifiers (WAS) and retained in the aeration basins (MLSS) is a critical part of any activated sludge system control strategy. The MLSS, WAS concentration, and RAS recycle rate measurements are routinely used to adjust the WAS withdrawal rate and to maintain consistent steady-state activated sludge system performance.

Currently, manual sludge sample collection followed by gravimetric TSS analysis in the plant laboratory is the most frequently practiced method for monitoring activated sludge MLSS, RAS and WAS concentration fluctuations. Typically, plant staff collects one to three sludge samples throughout the day and analyses these samples for total suspended solids applying standard laboratory methods and procedures or using laboratory high-speed centrifuges.

Standard laboratory TSS analysis is relatively time consuming (typically 2 to 3 hours needed to perform) and therefore, due to practical time constraints, is usually completed only a few times per day for larger facilities, and less frequently for smaller plants. Solids determination by centrifugation of activated sludge samples takes only 15 to 20 minutes and is widely practiced in many plants. Test results are developed in a graph correlating the volume of centrifuged solids (usually expressed as % of the total sample volume) to the sludge suspended solids concentration using parallel measurements of these parameters on the same sets of samples. The graph is then used for direct reading of the solids concentration based on the volume of the separated solids in the centrifuged sample. Although less accurate, the centrifuge test is relatively quick to complete, inexpensive and requires less skill to run than the standard gravimetric TSS analysis.



Fundamentals of Clarifier Performance Monitoring and Control

A SunCam online continuing education course

Currently, several sludge concentration analyzers are commercially available for on-line measurement and monitoring of MLSS and secondary clarifier WAS concentrations. Continuous solids concentration measurements allow for trending of solids inventory fluctuations in real time and provide a more accurate representation of the activated sludge system performance. In addition, automated solids inventory monitoring avoids the possibility of human errors and reduces the time required for sampling and sample processing.

Nonetheless, installation and operation of on-line instrumentation for solids inventory monitoring requires additional expense, more specialized operator skills for calibration and servicing of sensors, and frequent equipment field testing to avoid potential errors caused by inaccurate readings or instrument drift. Therefore, whether the use of such equipment is beneficial for the site-specific conditions of a given WWTP should be established based on site-specific lifecycle cost analysis.

Successful use of automated activated sludge solids inventory control systems has been reported at many medium and large size wastewater treatment plants (Ekster, 1998, 2000; Samuels, 2000; Hinton-Lever, 2000; Wheeler, et. al. 2001). An activated sludge system performance optimization study completed at the 93,000 m³/day (25 MGD) Burlington Skyway WWTP in Halton, Ontario, Canada (Wheeler, et al. 2001) has proven that automation of secondary clarifier sludge blanket level monitoring combined with close monitoring and control of activated sludge solids inventory can yield significant improvement of the plant effluent quality with minimal additional expense.

Monitoring of Sludge Settleability. While monitoring the sludge blanket, the activated sludge solids inventory, and the plant influent flow variations can provide a general understanding of the clarifier performance, it is also very advantageous to track changes in activated sludge settleability. As mentioned previously, primary and secondary sludge blanket depth and settleability do not fluctuate significantly under steady state influent flow and load conditions. A sudden increase in sludge blanket depth in the secondary clarifiers at typical influent flows and loads and well operating sludge withdrawal pumps, usually indicates deterioration of sludge settleability. Currently, there are a few widely-used parameters and procedures for determining activated sludge settleability.

Sludge settleability is central to the health of the biological system. It is important to point out that settleability is influenced by conditions in the activated sludge basin but manifests itself in the clarifier. Poor settling sludge causes lower solids concentration requiring higher RAS rates to



Fundamentals of Clarifier Performance Monitoring and Control

A SunCam online continuing education course

maintain a given MLSS in the activated sludge basin. Consequently, measuring sludge settleability is fundamental to the operation and control of the biological system.

Historically, the **Sludge Volume Index** (SVI) has been used most commonly as a measure of sludge settleability. It is defined as the volume in milliliters occupied by 1 g of the suspended solids following 30 min. of unstirred settling of the aeration basin MLSS. The test may be carried out in a 1 or 2 L settling column. It is expressed as follows:

$$\text{SVI (mL/g SS)} = V_{30} (1,000 \text{ mg/g}) / (XV_t)$$

Where,

V_{30} = Sludge volume after 30 min. of settling, mL;

X = Mixed liquor concentration before the test, mg/L;

V_t = Volume of settling column, L.

The popularity of SVI is partly due to the ease of measurement. However, SVI is not always a good measure of settleability and has several deficiencies. The most significant deficiency of the SVI as a measure of sludge settleability is its dependency on mixed liquor concentration. For well settling sludge, the MLSS concentration above which the SVI is influenced by the solids concentration is relatively high, and in such cases, SVI usually is a reasonably good measure for sludge settleability. For poor settling sludge, the critical MLSS concentration is low and SVI provides a poor characterization of sludge settleability.

Dilute Sludge Volume Index (DSVI) is another measure of sludge settleability, which has been developed and adopted by the water industry to overcome the above-mentioned problem with traditional SVI test. In the DSVI test, an effort is made to keep the 30 min. settled volume between 150 and 250 mL/L by dilution. Final effluent prior to chlorine addition is typically used for dilution to minimize the interference from foreign material.

$$\text{DSVI} = \text{DSV}_{30} / X_{\text{dil}}$$

Where,

DSV_{30} = Settled volume of the diluted sludge after 30 min of settling;

X_{dil} = MLSS concentration following the necessary dilution.



Fundamentals of Clarifier Performance Monitoring and Control

A SunCam online continuing education course

The upper limit of 250 mL/L was selected for DSV_{30} because the SVI is influenced by solids concentration above this level. Due to its relative insensitivity to solids concentration, DSV_{30} provides a common basis for comparing sludge settleabilities at different facilities.

Wall effects plague the traditional SVI test. The wall effects can be eliminated by slowly stirring the contents of the settling column as they settle. Stirring also minimizes short-circuiting and bridge formation. Consequently, the Stirred Specific Volume Index at 3.5 gMLSS/L ($SSVI_{3.5}$) represents the field conditions more closely than the traditional SVI. It is defined as the volume occupied by 1 g of solids following 30 min. of settling in a gently stirred (at 1 rpm) settling column at a standard initial concentration of 3.5 g MLSS/L (3599 mg/L).

Determination of $SSVI_{3.5}$ entails: (1) performing a range of settling tests at various MLSS values ranging from 2,000 to 6,000 mg/L, (2) calculating the $SSVIs$ for each concentration, (3) developing a $SSVI$ -concentration graph, and (4) obtaining the $SSVI$ value at 3,5000 mg/L by interpolation.

Plant Influent Flow and Load Monitoring. Accurate plant influent flow measurement and monitoring are essential for efficient control of the clarification process. In many plants, influent flow rate is used as a main activated sludge system control parameter, adjusting the transfer (RAS) rate of solids from the secondary clarifiers to the aeration basins proportionally to the influent flow changes. As a minimum, installation of on-line flow measurement devices is recommended for continuous monitoring of plant influent flow and RAS and WAS flowrates.

3. Monitoring and Control Equipment and Instrumentation

To date, automated clarifier monitoring and control has found application mostly in medium and large wastewater treatment plants. A recent survey of more than 110 wastewater plants at 45 utilities in the US (Hill, B. et. al., 2001) indicates that only 10% of the surveyed plants use primary or secondary clarifier sludge blanket level monitoring instrumentation and approximately 5 to 10 % of the plants apply suspended solids concentration analyzers. This survey also indicates that typically primary sludge withdrawal control is timer-based with feedback from sludge blanket depth to adjust frequency. Facilities included in the survey reported using constant flowrate secondary sludge wasting more than any other WAS control strategy. The second most popular WAS control strategy is based on maintaining constant **sludge age/solids retention time (SRT)** in the activated sludge system.

Installation of automated sludge concentration measurement and blanket-monitoring equipment is warranted for large treatment plants, where sludge withdrawal from the clarifiers is usually



Fundamentals of Clarifier Performance Monitoring and Control

A SunCam online continuing education course

continuous and where the sludge is treated in anaerobic or aerobic digesters. In small plants where sludge is usually removed intermittently, or for facilities with minimal influent flow and waste load variations, installation of sludge concentration and blanket depth measurement instrumentation may have limited benefits. The sections below discuss the existing technologies and equipment available for measuring sludge concentration, density and sludge blanket depth.

Monitoring of Clarifier Drive Unit Operation

Installing instrumentation for monitoring the clarifier sludge collection mechanism drive unit operation is a good engineering practice. The purpose of this instrumentation is to protect the clarifier drive gearbox and sludge collection flights/arms, ultimately preventing clarifier failure and the need for costly and lengthy repairs. Standard monitored drive unit parameters are: torque, power and motion detection.

Wastewater plant operators sometimes use torque gauges or motor power monitors for an indirect monitoring of clarifier sludge concentration (Wilkinson, 1997). This approach, however, is relatively simplistic and inaccurate due to torque gauges and power monitors being designed to provide protection of the clarifier driver mechanisms against overloading, rather than to indicate solids concentration.

Clarifier Drive Torque Monitoring. Most suppliers of clarifier drives provide drive torque monitoring devices as a part of their drive mechanism package. High and high-high torque warning, alarm, and shut-off switches are typically installed at each clarifier drive mechanism. The plant clarifier programmable logic controller (PLC) is set to monitor clarifier drive on/off (motion) status, the clarifier high and high-high torque warning/shut-off switches, and to generate alarms whenever any of these thresholds are met. Torque indication can typically be read from a scale, which is expressed as a percentage of the maximum torque load.

If the high torque warning switch senses a high-torque condition (typically when the torque load reaches 40 to 50 % of the maximum design drive torque) it sends a signal to the PLC, which generates a high-torque alarm. This alarm is usually displayed on the plant operator's main control panel. The PLC resets the alarm when the torque condition clears. If the high-high torque switch senses that the torque load reaches 80 to 85% of the maximum design drive torque, this switch sends a signal to the PLC to generate a high-high torque alarm at the plant operator's main control panel. If the plant operations staff does not turn the clarifier drive motor off after the actual torque reaches high-high level, the high-high torque switch will shut down the drive



Fundamentals of Clarifier Performance Monitoring and Control

A SunCam online continuing education course

motor in order to protect it from overload and the clarifier sludge collection mechanism from damage.

Some equipment manufacturers offer a positive torque overload protection for clarifier drives. A clarifier sludge collection mechanism drive with positive torque overload protection is designed to produce a controlled preset maximum torque. The drive will run continuously at this torque, but when needed, it will safely produce a higher, controlled, short-term running torque to keep the solids in the clarifier moving. When the drive with a positive torque overload protection experiences torque load demand above the high-high (cut-off) level, the drive will simply slip, without overheating or overstressing. This type of drives allows overcoming process upset without the risk of damaging the sludge collection equipment.

Clarifier Drive Power Monitoring and Sludge Pump Withdrawal Rate Control. Like torque, the clarifier drive motor power (measured in watts) or current draw/amperage (measured in amperes) could be monitored to provide motor and drive overload protection. Power monitors for alternate current (AC) motors are readily available by several manufacturers and can be connected to the wastewater treatment plant PLC to initiate high or high-high power load alarms and drive shut down, like that activated by the torque switches.

In addition, the power monitors could be used to control the clarifier sludge pump withdrawal rate. Installation of a power monitor on the clarifier motor and equipping the sludge withdrawal pump with a two-speed or a variable frequency speed motor will accomplish this. To determine the power monitor low and high level thresholds that indicate a change in the sludge pump withdrawal capacity, actual clarifier motor power readings are taken at acceptable minimum and maximum clarifier sludge blanket levels. These target sludge blanket levels are established based on full-scale operational experience.

When the power reading reaches the trigger level corresponding to maximum sludge blanket level, the power monitor sends an output signal to the plant clarifier PLC, which in turn increases the sludge pump motor speed to boost the sludge withdrawal rate and vice versa. The power monitor usually also has a low-low and high-high power level settings. At the low-low level setting, (which is typically below the low power level corresponding to the minimum acceptable sludge blanket level) the sludge withdrawal pump is automatically shut down the withdrawn sludge would be of unacceptably low solids concentration. The high-high level of the power monitor is introduced to prevent the clarifier motor drive from overload if the sludge pump fails and/or the clarifier sludge blanket level exceeds a preset maximum.



Fundamentals of Clarifier Performance Monitoring and Control

A SunCam online continuing education course

Clarifier Drive Motion Monitoring. The clarifier sludge collection mechanism motion is typically halted when the sludge blanket level in the clarifier is too high and excessive load is imposed upon the sludge collection flights/arms. Installation of loss-of-motion detection instrumentation is recommended as a minimum measure for clarifier drive and sludge collection mechanism protection. Typically, loss-of-motion switches are installed on the clarifier drives to detect when they stop moving. These switches usually generate an output signal to the plant clarifier PLC, which in turn triggers an alarm and may be programmed to automatically shut the drive motor off.

Sludge Concentration/Density Measurement

Sludge concentration and density measurements are used in wastewater treatment plants to monitor the solids concentration of various process streams in order to optimize primary and/or secondary treatment system performance. Usually, sludge removal from primary clarifiers is set on timers. This practice however, often leads to large variations of sludge concentration due to fluctuations of sludge blanket level and settleability over time. More consistent sludge solids content can be achieved by frequently or continuously measuring sludge concentration and adjusting withdrawal rate based on the measured concentration. Continuous readings/signals from the sludge concentration/density analyzers could be set to start/stop or control the speed of the sludge withdrawal pumps to minimize pumping of diluted sludge to downstream solids handling facilities.

In the past, sludge concentration/density measurement instrumentation has found limited application in full-scale plants, mostly due to equipment measurement inconsistency and inaccuracy. Analyzer instrumentation problems were typically caused by presence of air bubbles, sensor fouling or change in water color. The new generation of sludge concentration/density measurement equipment has built-in provisions to mitigate these problems and can provide consistent and accurate readings. Reliable sludge blanket and concentration analyzers are currently commercially available and have a proven track record.

Several different measurement methods/types of equipment are used for sludge concentration and density measurement, including light emitting (optical), ultrasonic, and nuclear type solids analyzers. Table 2 summarizes key areas of implementation of the various sludge concentration/density measurement technologies.



Fundamentals of Clarifier Performance Monitoring and Control

A SunCam online continuing education course

Some of the commercially available analyzers are combined with sludge blanket level detectors, which usually amplify the benefits of automatic sludge monitoring and control.

Table 2 - Areas of Application Of Sludge Concentration/Density Measurement Equipment

Typical Applications	Accuracy	Notes
LIGHT EMMITING (OPTICAL) ANALYZERS		
Sludge Density Meters: Sludge with solids concentrations from 0.1 % to 6 % solids Turbidimeters: Wastewater of turbidity between 0.01 and 10,000 NTU (TSS of 1 to 3,000 mg/L).	+/- 0.5 % of full instrument span	Avoid use for: <ul style="list-style-type: none"> - Primary Sludge of Above 3 % solids; - Thickened Sludge; - Wastewater with Visibly Apparent Color.
ULTRASONIC ANALYSERS		
Sludge with solids concentrations from 0.1 to 10 % solids	+/- 5 % of full instrument span	Avoid use for: <ul style="list-style-type: none"> - Wastewater; - MLSS below 2,000 mg/L.
NUCLEAR ANALYZERS		
Sludge with solids concentrations greater than 4 % solids and lower than 15 %.	+/- 0.5 % to 1 % of full instrument span	Avoid use for: <ul style="list-style-type: none"> - Wastewater; - MLSS, RAS and WAS; - Low-concentration Primary Sludge.

Light Emitting (Optical) Analyzers

Principle of Operation. The operation of light emitting (optical) analyzers is based on the scattering of a beam of light by the suspended particles in the wastewater/sludge (Figure 3). The amount of dissipated light is a function of the number and size of particles in the solids



Fundamentals of Clarifier Performance Monitoring and Control A SunCam online continuing education course

concentration. An analyzer will measure the dissipated light, the transmitted light or both and then convert the data into a solids concentration measurement., Optical analyzers have a light source that emits light of a given intensity and a photocell that measures the transmitted light and the degradation of light scatter intensity along the path of the light beam (See Figure 3). The actual configuration of the light source and the photocell in the measurement instrument varies with the manufacturer.

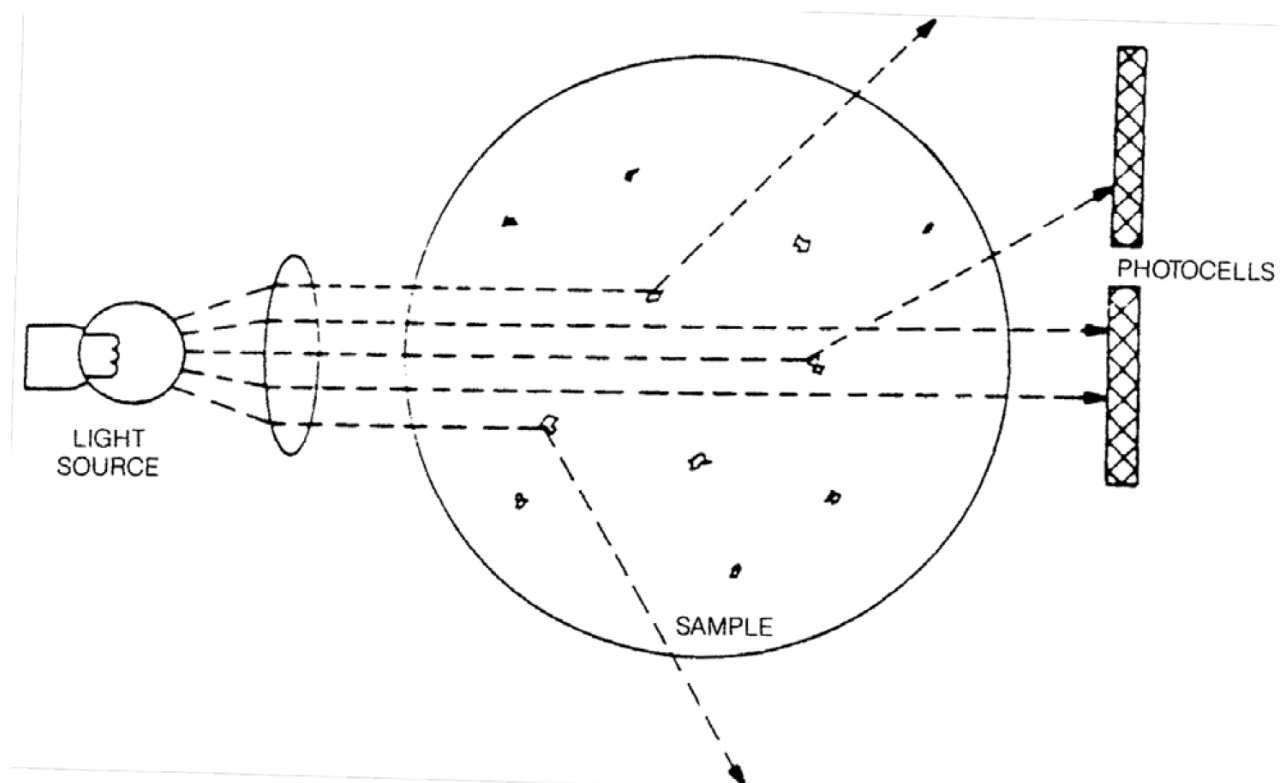

Figure 3 - General Schematic of Optical Solids Concentration Analyzer

Optical solids analyzers can be divided into two groups – **turbidimeters**, which typically present solids concentrations in **nephelometric turbidity units (NTU)** and **suspended solids concentration analyzers**, which indicate solids concentration in mg/L, g/l, ppm or percent. Some equipment manufacturers have combined solids analyzers that can measure both turbidity and solids concentration with the same sensor. To maximize accuracy, manufacturers normally offer different sensors for different solids concentration ranges and type of solids. , Optical suspended solids concentration sensors are divided into low, medium and high solids analyzers.



Fundamentals of Clarifier Performance Monitoring and Control

A SunCam online continuing education course

The solids/turbidity analyzers can be installed in two configurations:

- **submersed** – where the sensor is installed directly in the aeration basin or clarifier and supported by handrail mounting hardware or submersion extension pipe
- **inserted** – where the sensor is connected to the sludge conveyance pipe usually through a valve assembly flange enabling sensor insertion/removal without interrupting the process flow.

Typical Areas of Application. Optical solids analyzers can be used to measure a wide range of solids concentrations in both wastewater and sludge. Turbidimeter-type optical analyzers are most often used for monitoring plant secondary and tertiary effluent turbidity. This is prevalent where the plant effluent is applied for water reuse and effluent turbidity is a regulated water quality parameter. The turbidimeters can operate well within a range of 0.01 NTU to 10,000 NTU. Optical suspended solids analyzers are typically used to measure MLSS concentration and, less frequently, low-solids primary sludge. Optical type analyzers can be used to measure mixed liquor suspended solids, return activated sludge and waste activated sludge solids concentrations. They are not, however, recommended for measuring dissolved air flotation (DAF) sludge, thickened WAS with more than 6% solids, and thickened primary sludge with solids content higher than 3%.

Key Advantages. Optical analyzers are the most accurate instrumentation for measuring plant effluent turbidity, TSS concentration, and low-solids sludge (such as activated sludge). Their accuracy is typically +/- 0.5 % of the full measurement scale. Turbidimeters can measure very low turbidity concentrations, up to levels of 0.01 NTU. Turbidimeter costs are relatively low and units are easy to install, calibrate and maintain. Optical analyzers are currently the most widely used equipment for measuring activated sludge (MLSS and WAS) solids concentration.

Key Technology Limitations. Solids and algae buildup and coating of the source of light or the photocell are usually the key problems with optical solids analyzers in wastewater plants. Therefore, their performance and accuracy are highly dependent upon the frequent cleaning and calibration of the light source and sensors. Most of the newer generation commercially available optical analyzers are equipped with a self-cleaning assembly and have an optics arrangement that minimizes degrading factors, such as sensor fouling, from interfering with the solids concentration measurements. Scratch-resistant materials usually protect the system optics and some of the analyzers contain built-in provisions that compensate for measurement errors caused by air bubbles in the sludge or wastewater.



Fundamentals of Clarifier Performance Monitoring and Control

A SunCam online continuing education course

Optical analyzers have limited application when measuring solids in wastewater with visibly apparent color. The performance of this type of analyzer is affected by wastewater color. While color might not appear as particulate matter in a suspended solids monitoring application, the optical detector senses it as energy absorbent and reports it as suspended solids. Some of the state-of-the-art optical solids analyzers contain provisions to compensate for the effect of wastewater color on instrument readings.

Ultrasonic Analyzers

Principle of Operation. Ultrasonic analyzers include an ultrasonic signal source and a receiver (transducer). Particles in the sludge stream dissipate the transmitted ultrasonic signal proportionally to the concentration, resulting in an attenuated signal received by the transducer (Figure 4). Solids concentration is determined based on the speed of sound movement through the sludge. Most of the existing commercially available ultrasonic analyzers have simplified calibration procedures that allow setting the instrument solids concentration reading to 0.0 % solids or mg/L in clean water and then calibrate in a known solids concentration. The calibrated ultrasonic meter gives linear readings between these two settings.

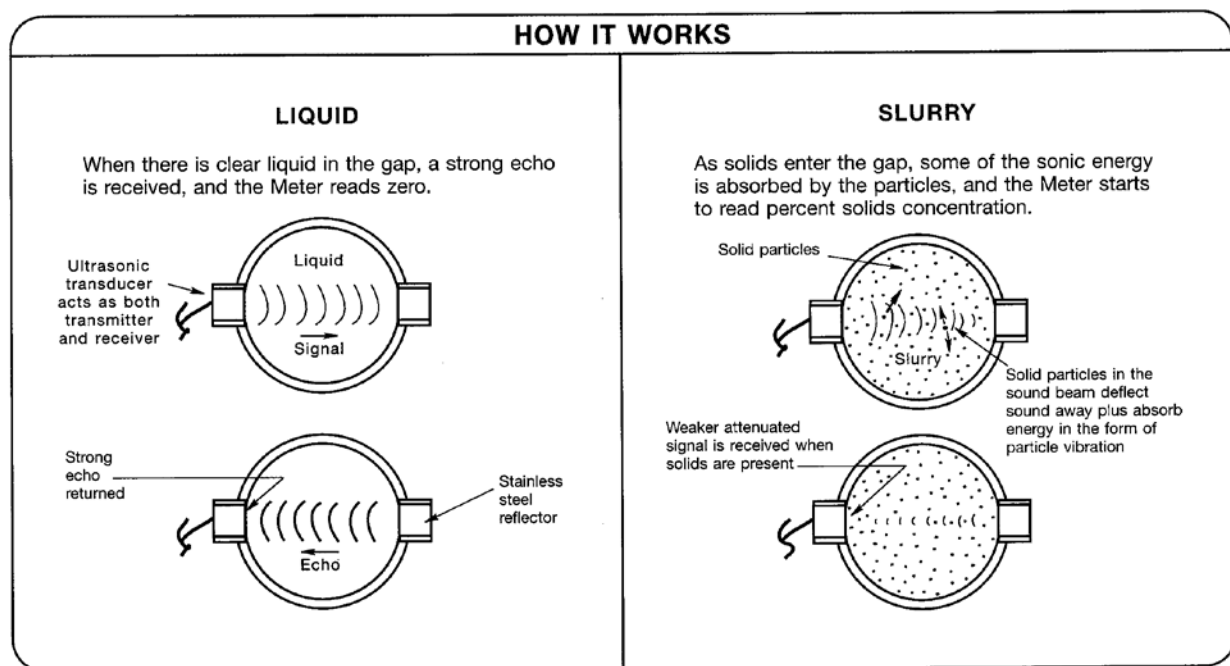

Figure 4 - General Schematic of Ultrasonic Solids Concentration Analyzer



Fundamentals of Clarifier Performance Monitoring and Control

A SunCam online continuing education course

Ultrasonic analyzers are usually outfitted with self-diagnostic programs that continuously monitor the analyzer's operation for malfunctions such as broken wires, improper voltage of the generated reading signal, etc., thus providing an early warning in the event of an equipment issue.

Typical Areas of Application. Ultrasonic analyzers are ordinarily used to measure sludge concentration that falls in the range of 0.1 % to 10 % solids and is most accurate at the medium to high end of this range. The exact range of operation depends upon the sonic attenuation of the particular sludge and the length of the sound path. The typical accuracy of the ultrasonic analyzers is +/- 5 % of the full scale.

Ultrasonic analyzers are most widely used for measuring primary sludge, WAS and RAS concentrations. They are not appropriate for monitoring plant effluent, MLSS concentration or plant sidestreams of TSS concentration lower than 1,000 mg/L. For in-line installations, ultrasonic solids analyzers can be used on pipe sizes between 100-300 mm (4-12 inches)..

Key Advantages. Ultrasonic solids analyzers are relatively inexpensive devices for measuring medium to high sludge solids content. Unlike optical analyzers, they are very suitable for monitoring primary sludge concentration but not for measuring aeration basin MLSS. The key advantage of ultrasonic analyzers, compared to optic sludge sensors, is that their performance is not sensitive to changes in wastewater color and to high concentration of gas bubbles. This makes ultrasonic analyzers the preferred solids measurement device for dissolved air flotation systems.

Key Technology Limitations. Like optical analyzers, ultrasonic solids analyzers are prone to solids buildup and coating of the ultrasound sensor. They have limited accuracy when measuring low density sludge with solids concentration below 0.3 % and very high density sludge with solids content above 10%.

Nuclear Density Analyzers

Principle of Operation

Nuclear solids analyzers are non-contact density gauges that measure the specific gravity of the sludge rather than its concentration. If the specific gravity of the solids and the water do not change significantly over time (plant influent wastewater is of relatively consistent quality), then the specific gravity measured by the nuclear analyzer can be correlated to the sludge solids concentration.



Fundamentals of Clarifier Performance Monitoring and Control A SunCam online continuing education course

The key component in nuclear density analyzers is the radioactive gamma ray source (Cs 137 or Co 60) that is contained inside a lead-filled, steel-encased housing. Solids in the sludge absorb a portion of the gamma ray source radiation while the remaining radiation is measured by a scintillation detector. The radioactive source and detector are located on the opposite sides of the pipe (Figure 5).



Figure 5 – Nuclear Density Analyzer

A continuous focused beam of radiation is transmitted from the radioactive source through the pipe sludge to the scintillation detector. When the radiation reaches the scintillation crystal of the detector, the analyzer generates a signal that is proportional to the sludge density. This is transmitted to the equipment electronics for conversion to a 4-20 mA or other useable process signal. As the density of the sludge in the pipe changes, the amount of radiation reaching the detector varies. The greater the sludge density/concentration, the lower the radiation intensity that reaches the detector and vice versa.



Fundamentals of Clarifier Performance Monitoring and Control

A SunCam online continuing education course

Typical Areas of Application. Nuclear density analyzers are suitable for thickened sludge of high solids content (typically 4 % or higher). They cannot be used for measuring plant effluent turbidity or TSS concentration, or unthickened primary and secondary sludge. These analyzers can measure sludge density of up to 15 % solids content. Nuclear density analyzers can typically be installed on pipes of sizes between 150 mm (5 inches) and 350 mm (14 inches). However, some equipment manufacturers recently introduced nuclear density analyzers that can be used for a wider range of pipe sizes (25-100 mm (1-42 inches)).

Key Advantages. The nuclear analyzer is the only sludge density/concentration measurement device that does not have direct contact with the measured sludge, and therefore requires little maintenance. The non-contact feature of these analyzers makes them very suitable for abrasive, corrosive, high-pressure and high-temperature applications. This device has no moving parts and is reasonably sensitive to sludge concentration variations. Nuclear analyzers are bracket-mounted to the sludge conveyance line and can be located practically anywhere along this line (see Figure 5).

Key Technology Limitations. Nuclear density analyzers are relatively expensive solids measurement devices when compared to optical or ultrasonic analyzers and. They cannot measure low-concentration solids streams (below 4% solids) with any accuracy that is comparable to the other two types of analyzers previously described. In addition, they must be installed and maintained by operators trained and licensed in handling radioactive material (training is usually provided by the analyzer manufacturers).

The nuclear sludge density analyzers can operate properly only if the sludge conveyance line is full. These analyzers are best at measuring the density of relatively homogenous sludge with temperature and consistency that does not change significantly over time. Nuclear analyzers are not suitable for solids streams with entrapped air bubbles (such as dissolved air flotation thickened sludge) or at municipal wastewater plants that have significant industrial wastewater contributors with frequently changing wastewater characteristics (i.e. cyclic discharges of large amounts of oil and grease, high temperature industrial waste or great variations in density).

Nuclear density analyzers are highly accurate measuring devices (+/- 0.5 to 1 % of full instrument scale). However, since the solids concentration readings are based on a correlation between the measured specific gravity and the solids content, significant changes in the specific gravity of the measured sludge will affect their accuracy.

Installation of Solids Analyzers



Fundamentals of Clarifier Performance Monitoring and Control A SunCam online continuing education course

The installation method for sludge concentration/density measurement devices depends on the type of instrument and recommended manufacturer installation details. The best location for in-line sludge concentration measurement devices is on a vertical line with an upflow. The solids concentration measurement device must be installed at a location where the sludge is well mixed and accurately represents the actual concentration. The operation range of the instrument must match the range of the measured solids concentration. Measurement devices should be located in such a manner that they are easy to access and maintain.

Common practice is for in-line solids analyzers to be calibrated weekly. The analyzer sample lines (if used) should be flushed weekly and their flow checked daily to maintain consistent instrument performance and accuracy. The analyzer probe must be easy to remove for service without shutting down process piping and disturbing the operation of the sludge pumping system (Figure 6). Depending on the skills of the plant staff, in-line solids analyzer calibration and maintenance may require a total of 3 to 6 hours per unit per week.

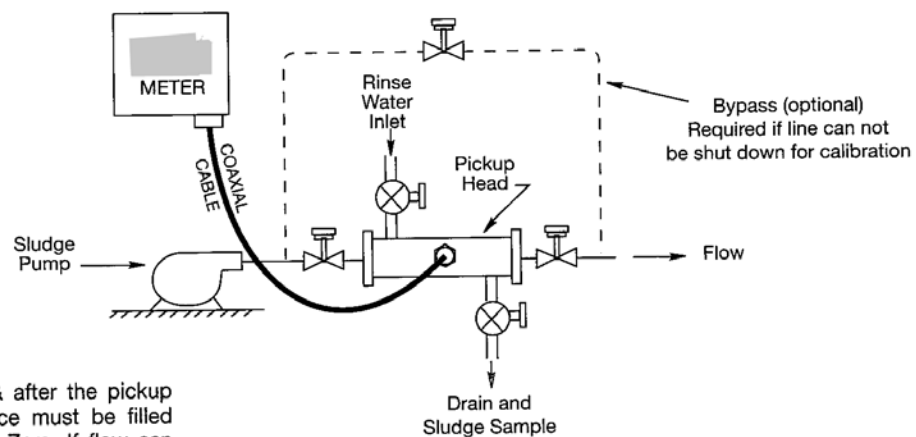

Install a gate valve before & after the pickup head. The flanged spoolpiece must be filled with clear water to calibrate Zero. If flow can not be shut off during calibration & flushing, install a bypass as shown.

Figure 6 - Installation of Sludge Solids Concentration Analyzer

Sludge sample lines must be large enough to prevent plugging. It is recommended to provide a flushing tap next to the instrument as well as a sample box, so samples can be collected manually at the point of instrument installation for calibration purposes.

For large wastewater treatment plants, separate measurement devices are recommended to be installed on the sludge withdrawal lines from the individual clarifiers to gain a better control over



Fundamentals of Clarifier Performance Monitoring and Control

A SunCam online continuing education course

the operation and performance of these units. Sludge density measurement devices must be installed coupled along with sludge flow measurement devices. The displays of the sludge concentration and flowrate measurement instrumentation should be located adjacent to each other for direct observation and comparison.

In-line solids analyzers are usually used to measure primary sludge, WAS and RAS concentration. When measuring MLSS concentration in aeration basins, analyzer sensors are directly immersed in the basins and mounted on holders off the basin walls. If a wall-mounted optical solids concentration analyzer is used, the sensor should be immersed at least 0.04 meters (1.5 inches) below the activated sludge tank water surface and should be located at a minimum 0.15 meters (6 inches) away from the aeration basin wall. If the wall is bright and reflective, the distance from the sensor to the aeration basin wall should be at least 0.3 meters (12 inches). Installing the optical sensor too close to a wall can cause infrared light backscatter, resulting in a higher intensity signal. Optimum self-cleaning of immersed suspended solids analyzers is achieved by turning the sensor surface into the flow direction.

Sludge Blanket Depth Measurement

Sludge blanket depth is a key indicator of primary and secondary clarifier performance. The depth of the sludge blanket is the distance from the clarifier surface to the blanket top. The blanket thickness is the distance from the top of the sludge blanket to the bottom of the clarifier. Sludge blanket typically varies daily within certain predictable limits due to diurnal flow fluctuations. The blanket depth may also vary because of process changes induced by the plant operators.

Day-to-day fluctuations of clarifier sludge blanket in a plant operated under relatively stable conditions are minimal limited to within 0.3 to 0.6 meters (1 to 2 feet). Significant and abrupt changes in sludge blanket depth in clarifiers are typically caused by either a significant increase in influent flow (transient flow conditions) or by a stoppage/malfunction of the sludge collection and/or withdrawal systems.

In primary clarifiers, sludge blanket depth is one of the main parameters that triggers initiation of sludge withdrawal. In secondary clarifiers, this parameter can be influenced by several activated sludge system performance changes and its fluctuations over time provide critical information for the overall health of the activated sludge system. Therefore, sludge blanket depth is one of the most frequently monitored parameters in wastewater treatment plants.



Fundamentals of Clarifier Performance Monitoring and Control

A SunCam online continuing education course

Manual Sludge Blanket Measurement. Currently, sludge blanket level at full-scale treatment plants is most commonly determined by manual measurements using a calibrated clear plastic tube (also named “core sampler” or “sludge judge”). To take a reading, the operator lowers the tube into the clarifier while holding a valve located at the bottom of the tube opening. After reaching the tank bottom, the operator closes the valve and carefully removes the tube, which is now filled with solids to a level. Some samplers (i.e. the “sludge judge”) have a ball check valve at the bottom of the tube that is open as it is lowered and closes when it is raised. If the sample has been collected correctly, the depth of sludge in the tube will match the depth of the sludge blanket in the clarifier at the sampling location.

The key disadvantage of manual sludge blanket depth measurement is that it is a discrete sample measurement that gives only a snapshot representation of the sludge blanket level at a given time and location. Variables such as the sampling location and time, the location of the sludge collection mechanism at the time of the measurement, the speed of the tube descent, the ambient light conditions, and the subjectivity of operator readings and sampling skills contribute to sometimes limited benefits of the manual sludge blanket measurement.

One key advantage of the manual plastic-tube sampler, is that it also allows for collection of a sludge sample with a TSS concentration that is representative of the average solids concentration of the sludge blanket. This parameter could be used to calculate the sludge blanket solids retention time and ultimately to determine the optimum sludge withdrawal rate. Manual plastic-tube samplers are reliable, inexpensive, virtually maintenance-free, and can be easily replaced if damaged. In addition, one manual plastic-tube sampler can be used to monitor multiple clarifiers. An alternative manual device for sludge blanket depth measurement is the sight glass. This apparatus consists of a sight glass and light source attached at the lower end of a graduated piece of aluminum pipe approximately 38 mm (1.5 inches) in diameter. The sight glass is carefully lowered into the clarifier through the zones of clear liquor and individual particles, until the top of the homogenous sludge blanket is observed.

For small plants and plants with clarifiers, where the sludge blanket does not vary significantly over time, manual sludge blanket depth measurement is usually an adequate, simple and low-cost method for determining sludge blanket depth. **Automated Sludge Blanket Level Measurement.** In medium and large wastewater treatment plants with more complex activated sludge and solids handling systems, instrumentation for continuous sludge blanket measurement interlocked with automated control of primary and secondary sludge withdrawal systems warrants consideration. Use of sludge blanket level monitoring and control systems allows minimizing solids handling



Fundamentals of Clarifier Performance Monitoring and Control

A SunCam online continuing education course

costs by reducing the volume of water pumped and processed with the sludge. Dakers (1985) has found that sludge volume could be reduced by approximately 50% if automated sludge blanket control is used instead of manual clarifier desludging. A survey of automatic sludge removal systems in the UK (Burke et al., 1985) also points out that primary clarifier sludge concentration could be increased by up to two times when clarifiers are desludged automatically by blanket level control. The benefits of automated sludge blanket depth measurements for WAS and RAS flowrate control have also been documented at a number of full-scale wastewater treatment plants (Bush, 1991; Dartez, 1996; Ekster, 1998 & 2000; Hinton-Lever, 2000; Hoffman and Wexler, 1996; Samules, 2000 and Rudd & al., 2001).

Automated sludge blanket depth measurement should be considered for wastewater treatment plants with significant variations of diurnal influent water quality and quantity, and associated frequent shift of sludge blanket levels. In cases where sludge blanket level fluctuations are frequent (blanket level changes up and down several times per day with more than 0.32 meters (1 foot) per change) and clarifiers are relatively shallow (i.e. clarifiers with a sidewater depth of less than 3.66 meters (12 feet)), use of variable frequency drive (VFD) motors for the sludge withdrawal pumps is recommended. If VFD controlled motors are used, sludge blanket monitoring instrumentation and pump control equipment operation can be interlocked to automatically adjust clarifier sludge pump withdrawal rate to keep sludge blanket at an optimum, near constant level.

Sludge Blanket Level Detectors

Most of the commercially available sludge blanket level detectors are based on ultrasonic or optical measurement of sludge concentration. These devices usually have provisions for compensating sensor measurement for temperature, fouling and aging.

Ultrasonic Sludge Blanket Level Detectors. Typically, ultrasonic sludge blanket detectors have a sensor located just below the water surface of the clarifier that continuously emits pulses of ultrasonic energy (Figure 7). These pulses are reflected in the form of echoes from suspended solids layers in the clarifier, detecting the interface between the light solids in the clarification zone and the sludge blanket. The blanket level analyzer then digitally converts the round-trip time of each pulse to compute the sludge blanket level and depth. The level measurement is displayed numerically and can be transmitted to the plant process monitoring and control system. Ultrasonic level analyzers can also be used to develop a profile of the sludge concentration throughout the clarifier. They can measure sludge blanket levels between 1 and 11 meters (3.3 to 36 feet) with an accuracy of +/- 1 % of the reading and signal resolution of 0.03 meters (0.1 foot).



Fundamentals of Clarifier Performance Monitoring and Control
A SunCam online continuing education course



Figure 7 – Ultrasonic Sludge Blanket Level Detector

Optical Sludge Blanket Level Detectors. Optical sludge blanket level measuring systems consist of a pulsed infrared light sensor immersed below the clarifier surface that is attached to a cable driven up and down by a stepper motor equipped with worm gear (Figure 8).



Fundamentals of Clarifier Performance Monitoring and Control
A SunCam online continuing education course

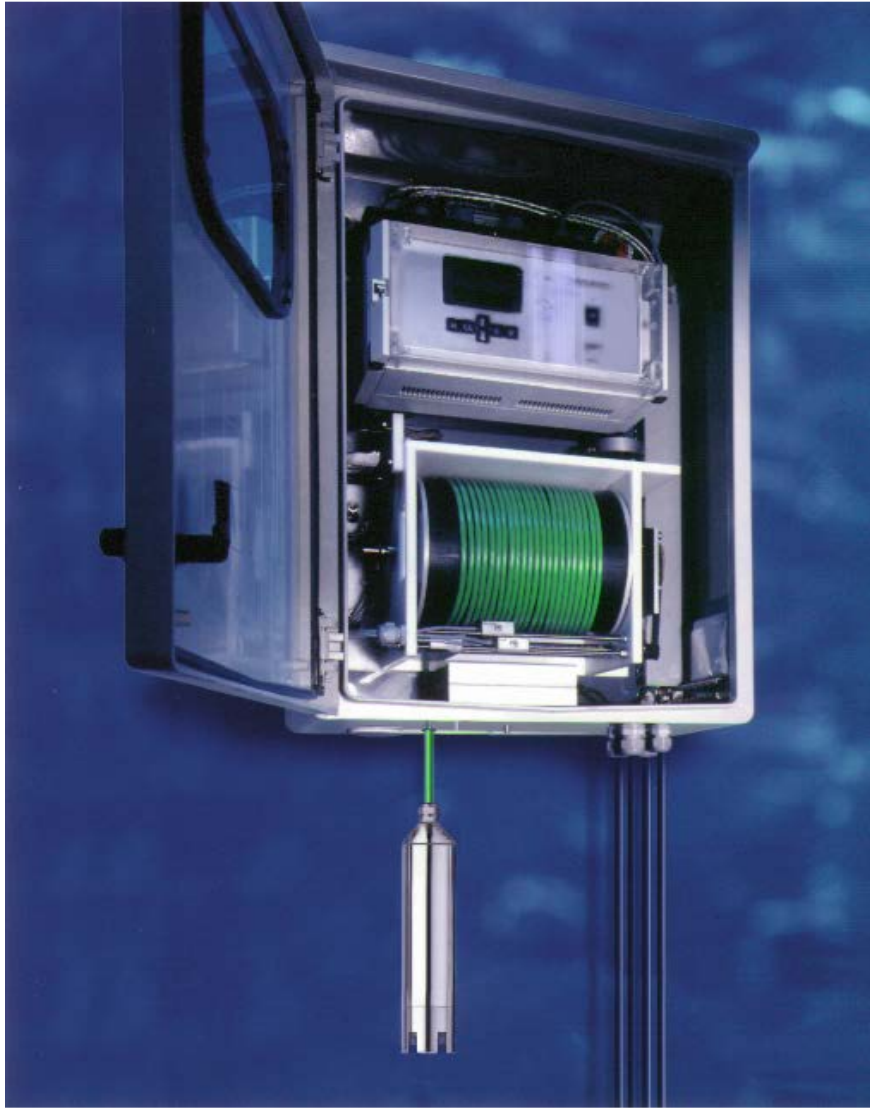

Figure 8 – Optical Sludge Blanket Level Detector

Clarifier zones of different solids density are detected by measuring suspended solids concentration based on infrared light absorption. The optical sensor generates signal proportional to the concentration of solids in suspension, which is converted into a frequency signal. The measured signal is compared with a pre-selected reference value for sludge concentration in the measuring transmitter. If there is a deviation, the sensor is moved up or



Fundamentals of Clarifier Performance Monitoring and Control

A SunCam online continuing education course

down by the stepper motor until it reaches the sludge blanket zone of a particular concentration targeted for measurement. The optical sludge blanket measurement device determines the sludge blanket level from the number of steps carried out by the stepper motor and converts the result to an analog signal. Like ultrasonic analyzers, optical sludge blanket level detection systems can be used to measure blanket levels between 1 and 11 meters (3.3 to 36 feet) with an accuracy of +/- 1% of the measured value.

Typical Areas of Application. Sludge blanket level analyzers are typically used to track blanket depth shifts to prevent clarifier performance failures and maximize sludge concentration. The same analyzers can be used in both primary and secondary clarifiers.

Ultrasonic sludge blanket level detectors have found a wider application to date, usually due to their extended capabilities to produce continuous clarifier solids density profiles and lower cost. For a typical, well settling sludge, ultrasonic analyzers produce very consistent readings. However, these analyzers may not be as accurate as infrared optical analyzers at plants experiencing slowly settling or frequently bulking or floating sludge, because these types of sludge do not have a well-defined ultrasonic echo. Under such conditions, optical sludge blanket level detectors would be a better choice.

The automated sludge blanket level measurement instrumentation is usually interlocked with the sludge withdrawal pumps that are activated automatically when the sludge blanket reaches certain level and automatically shut down when the sludge solids decrease below a certain target concentration. Compared to manual sludge withdrawal, the use of sludge level control avoids pumping low-solids sludge during periods of low flows and light solids loading and to automatically stop sludge pumps when their suction begins creating funnels (“rat holes”) in the clarifier sludge blanket.

Newer generation sludge blanket monitoring systems are microprocessor-based and can be easily integrated in to the plant centralized monitoring and control system. Some of the commercially available sludge blanket level analyzers provide a graphical representation of the suspended solids profile in the clarifier and alarm indication when sudden changes of the sludge blanket level occur (Figure 9). Level signal from the sludge blanket level analyzers can be transmitted to the plant control system and the main control room for direct visual monitoring by the operators on duty.



Fundamentals of Clarifier Performance Monitoring and Control
A SunCam online continuing education course

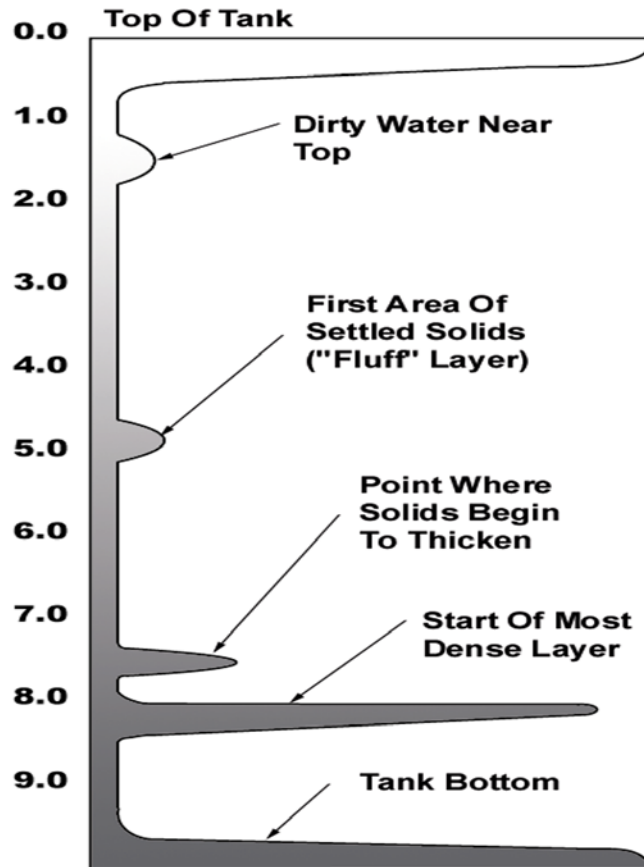

Figure 9 – Sludge Blanket Profile

Key Technology Limitations. The benefits of continuous sludge blanket monitoring are less pronounced for small treatment plants with relatively small variations in plant influent flow and waste load, and relatively deep clarifiers that have available large sludge retention volume, and can carry significant blanket fluctuations.

Ultrasonic sludge blanket level analyzers are subject to “blinding” by gas bubbles. In primary clarifiers, septicity of the primary sludge creates gas bubbles. Conversely, in biological nutrient removal systems, nitrogen gas bubbles are generated due to uncontrolled denitrification in the secondary clarifiers. Gas bubbles trapped on the surface of the sonic sensor will alter the sensor readings. Therefore, the ultrasonic sensors must be designed with cleaning provisions. Usually,



Fundamentals of Clarifier Performance Monitoring and Control

A SunCam online continuing education course

small utility water pumps are installed on the rail above the sensor or t on the sensor. These pumps typically run intermittently and wash the sensors to maintain accuracy of the instrument readings.

Higher costs and relatively lower accuracy limit the use of optical sludge blanket level detectors. Optical analyzers are subjected to interference by accumulation of solids on the analyzer sensor and by light reflection from nearby objects (smooth walls and sunlight reflecting tank and equipment surfaces).

Installation Of Sludge Blanket Level Detectors

Blanket level detectors must be installed in locations that do not cause interference with the normal operation of the sludge collection and removal system. Normally, the stationary sludge blanket meters are installed on the catwalk or on the side rail of the clarifiers (Figure 5). The stationary ultrasonic sludge blanket sensors are typically mounted 4 to 8 cm (1.5 to 3 inches) below the liquid surface and are equipped with skimmer guards to protect the sensors from damage.

The best location for measuring sludge blanket depth is where the actual depth is equal to the average clarifier depth. In circular clarifiers, this point is typically one-third of the distance from the outside wall of the clarifier center to the middle. In rectangular clarifiers, the most appropriate location of routine sludge blanket measurement is usually at the mid-point of the clarifier basin length. Since clarifier configuration, type and size vary, the most representative location for measurement of the average sludge blanket depth should be established based on a series of manual sludge blanket measurements at three to five locations along the clarifier radius/length.

Typically, sludge collection arms of circular clarifiers rotate approximately once every 15 to 30 minutes and the sludge collection mechanism (scraper or suction header) movement disturbs the sludge blanket. If the sludge blanket is measured manually, the sludge blanket depth readings should be taken when the sludge collection mechanism (bridge) is perpendicular to the measuring location. Taking sludge blanket level measurement at this location minimizes the effect of sludge collection mechanism movement on the measurement. When sludge blanket level measurements are collected manually, at least two measurements must be completed: one with the sludge collection arm at 90 degrees and one at 270 degrees from the bridge. These two measurements must be averaged to determine the average sludge blanket depth.



Fundamentals of Clarifier Performance Monitoring and Control

A SunCam online continuing education course

Automated sludge blanket level analyzers typically take continuous (several times per second) interface level readings. This allows the operating staff to observe the sludge blanket behavior in real time. Blanket depth measurement instrumentation can produce “average” sludge blanket level or interface level by averaging the sludge profile at preset intervals of 15 to 60 seconds, which eliminates wide changes in the blanket level readings caused by sludge collection rake passage or temporary –short-term sludge blanket upsets.

Individual automated sludge blanket level analyzers should be installed in all clarifier units of the wastewater plant, rather than installing a blanket level detector in only one clarifier. The detector reading can be used to judge the sludge blanket levels in all the other plant clarifiers. Comparison of sludge blanket behavior in each unit allows quick identification and resolution of potential problems related to uneven flow distribution among the clarifiers, malfunction of clarifier sludge collection and withdrawal systems, or other site specific events that cause individual clarifier units to perform differently.

For example, Figure 10 shows sludge blanket profiles of two identical clarifiers at the same plant performing differently at the same time. The vertical axis of this figure indicates the clarifier depth. The depicted tank is 14-feet deep. The “0” level corresponds with the top of the tanks (shown at the bottom of the figures). The horizontal axis represents the solids density along the depth of the clarifiers.

Clarifier Units 1 and 2 receive the same sludge at the same rate. Both clarifiers have sludge blankets at almost the same depth. However, the sludge blanket profile indicates that Clarifier Unit 2 performance is inferior and is experiencing a solids washout. In this case, a malfunction of the sludge withdrawal pumps caused the washout.

Selection of Monitoring Equipment

Selection of the most appropriate instrumentation for a specific application is critical for the reliable monitoring and control of clarifier solids concentration and sludge blanket. Most sensors perform well under ideal conditions that manufacturers use to determine their specifications for accuracy, reproducibility and other key operational parameters. However, sensor performance in the field is sometimes unsatisfactory and requires a period of calibration and adjustment to the site-specific conditions of the application (Hill et al., 2001).

Instrumentation field testing is invaluable in providing the information needed to select the most appropriate type and model of equipment for a given application. Although on-site testing by the



Fundamentals of Clarifier Performance Monitoring and Control

A SunCam online continuing education course

end user is the most reliable approach to select the best monitoring system, such testing could be costly and time consuming. Therefore, the extensive testing experience and equipment performance assessment information of organizations specializing in the evaluation of water and wastewater treatment plant monitoring equipment, such as the Instrumentation Testing Association (ITA), are recommended to be used to aid and expedite the instrumentation selection process.

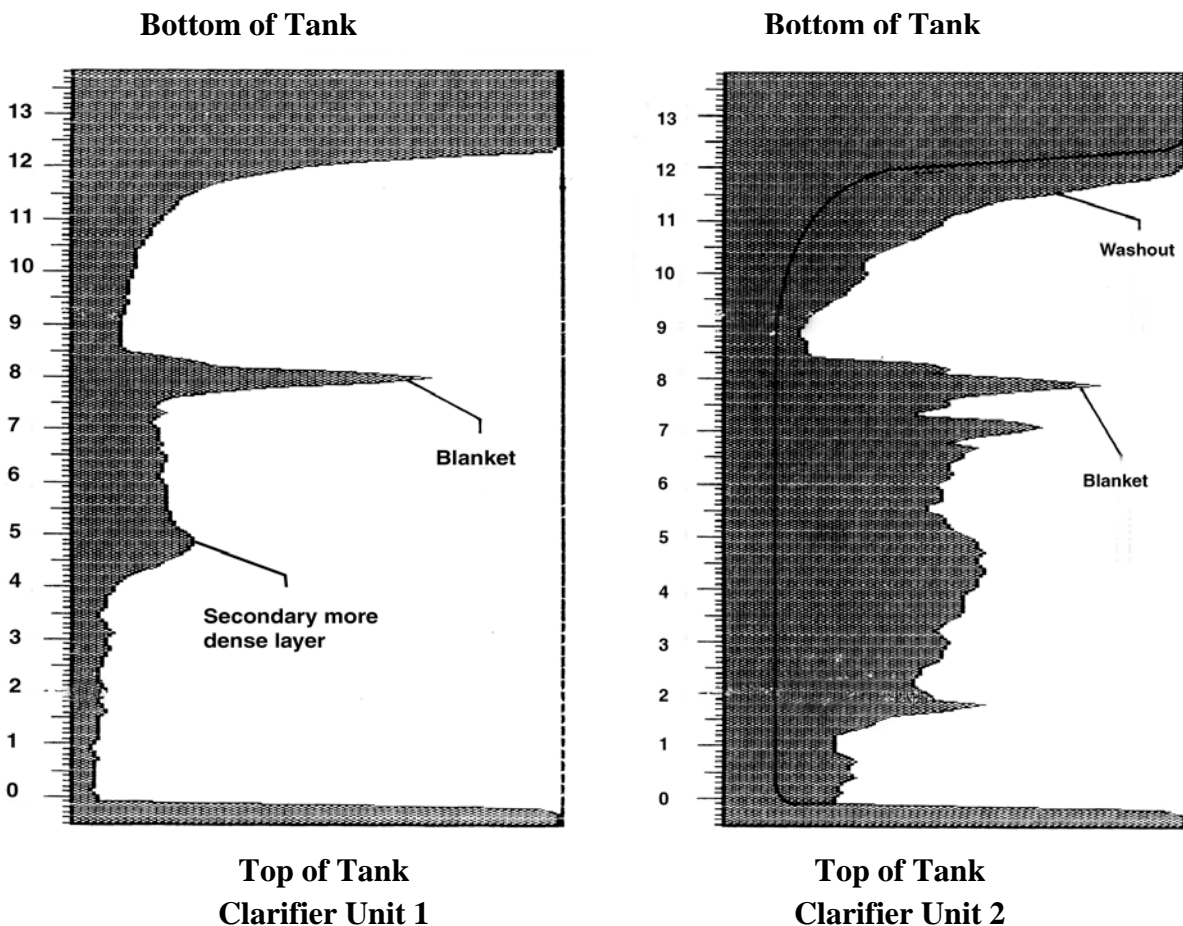

Figure 10 – Comparison of Sludge Blanket Profiles in Two Identical Clarifiers

4. Case Studies

Activated Sludge Solids Inventory Monitoring – San Jose/Santa Clara Water Pollution Control Plant, CA

The 632,000 m³/day (167 MGD) San Jose/Santa Clara Water Pollution Control Plant in San Jose, California (Figure 11) uses on-line equipment for measurement of secondary clarifier WAS and MLSS for an automated waste activated sludge control (Ekster, 1998, 2000).



Fundamentals of Clarifier Performance Monitoring and Control A SunCam online continuing education course



Figure 11 – Areal View of San Jose/Santa Clara Water Pollution Control Plant

The automatic WAS removal rate/SRT control system provided efficient real-time control over solids inventory that allowed for a substantial reduction in activated sludge bulking and *Nocardia* foaming, improved effluent quality and decreased chemical usage for phosphorus removal and disinfection. In addition, the use of the automated WAS control system reduced routine manual clarifier sludge garb sampling and analysis by 80%. The estimated payback period for the automatic waste control system implementation was less than three years.

The automatic waste control system (see Figure 12) consisted of analyzers for measuring MLSS concentration in the aeration basin and the WAS concentration, a controller (computer), a flowmeter, and a motorized control valve installed on the WAS line. Sludge concentration signal from the analyzers was transmitted to the controller. The controller compared the operational criteria (MLSS concentration or solids retention time) with their target values, calculated the necessary adjustment of the WAS flowrate, and sent a control signal to the motorized valve located on the WAS line.



Fundamentals of Clarifier Performance Monitoring and Control A SunCam online continuing education course

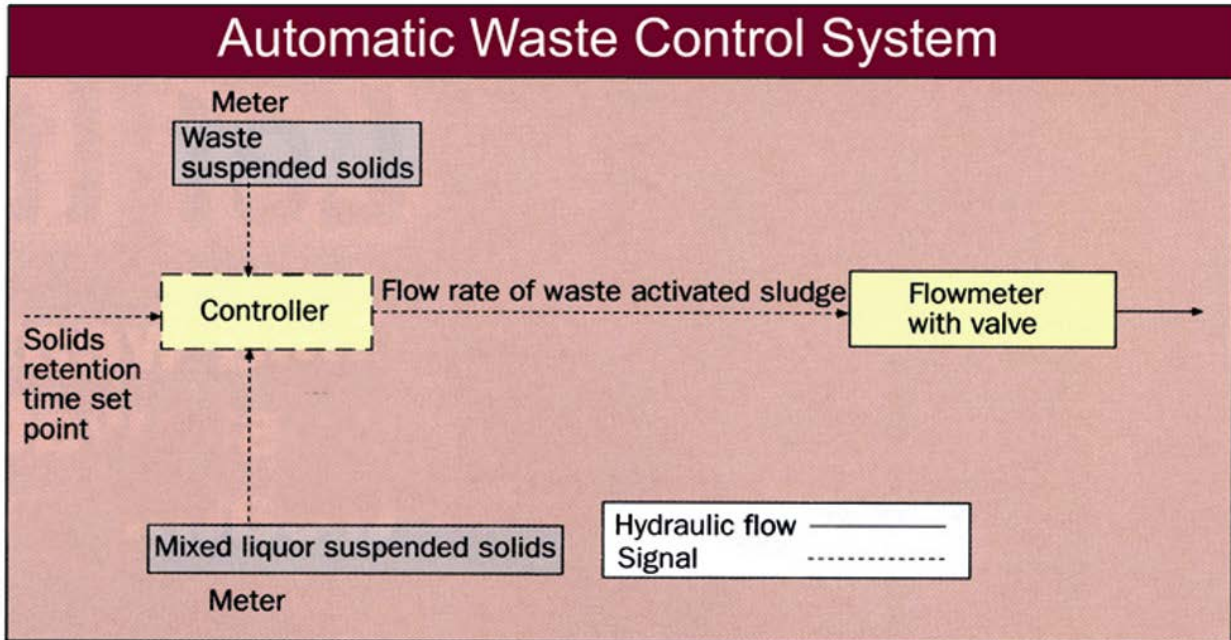

Figure 12 – Schematic of Automatic Waste Control System

The installation of the automated SRT control system resulted in a significant reduction of WAS flowrate variation. Fluctuations of RAS and MLSS concentrations were reduced by almost three times, while WAS flowrate variation was reduced by a factor of seven. The significant reduction in WAS flowrate variation improved sludge thickener operation and the earlier practice of bypassing caused by overload of thickeners became unnecessary. Polymer usage for sludge dewatering was also reduced by almost 50% because of the improved activated sludge dewaterability (elimination of the *Nocardia* bulking sludge problem).

Plant operators could select and adjust target SRT set-point, wasting strategies and limits of system operation. The controller handled both continuous and intermittent wasting strategies. Continuous wasting was set to maintain either a stable flow or a stable load, depending on the capacity of the secondary clarifiers. Intermittent wasting was set-up with either fixed pump time schedules with flowrate control or fixed flowrate operation with variable pump time controls. Pump schedules for the entire week were able to be programmed, with up to four start and stop times each day.

The operator safeguarded the control process by specifying the range of allowable MLSS, flowrate or pump times and load values. The control system alerted the operator if any of these ranges need to be exceeded to maintain a preset optimal SRT. It also generated suggestions as to



Fundamentals of Clarifier Performance Monitoring and Control

A SunCam online continuing education course

what ranges might be changed for improved control. If waste flow or wasting time had to be temporarily changed, in the case of a dangerously high sludge blanket level for instance, the operator could override the controller. The mass of wasted sludge in the manual mode is also included in the controller calculations when automatic waste mode is reinstated. When the SRT target value needed changing, the controller altered the value gradually, eliminating the possibility for process upsets. A change in SRT target is usually considered in cases of temperature change, in anticipation of shock loading, a significant change in wastewater characteristics or sludge settling characteristics.

When an aeration tank was taken offline, it was relatively simple to alter the controller to compensate for the reduced process volume. The SRT controller promoted stability and reliability and detected whether system elements were operating correctly. The operator was alerted if MLSS, RAS or WAS flowrate values change in an unusual manner.

On several occasions, the reliability of the automated SRT control system was challenged when the RAS flow from the sampling sink was interrupted, and thus the RAS sludge concentration analyzers produced invalid readings. The control system automatically detected problems with the RAS sludge concentration analyzer readings, activated warning alarms and automatically changed the control algorithm to ensure that the faulty readings were disregarded. Once conditions returned to normal, the controller automatically changed the control algorithm back to the one used prior to the problems occurring.

Sludge Concentration Monitoring – Clark County Sanitation District, Las Vegas, Nevada

The 333,080 m³/day (88-mgd) Clark County Sanitation District biological nutrient removal plant in Las Vegas, Nevada consists of eight 41,635 m³/day (11-mgd) aeration basins each with dedicated secondary clarifier (see Figure 13). The plant staff successfully automated the secondary clarifier waste activated sludge withdrawal system, achieving improved nutrient removal coupled with cost saving and reduced operator attention, lab time, and ferric chloride use (Bain, 1998). Taking under consideration all savings achieved by fully automating activated sludge system solids inventory control, the payback period of the improvements was less than 3 years.



Fundamentals of Clarifier Performance Monitoring and Control A SunCam online continuing education course



Figure 13 – Clark County Sanitation District BNR Plant Secondary Clarifiers

Before the implementation of the automated WAS withdrawal system, plant staff followed a conventional procedure of controlling activated sludge solids inventory by collecting grab sample of MLSS and RAS, analyzing the MLSS and RAS concentration and calculating the new target wasting rate as follows:

$$\text{New WAS Removal Rate} = (\text{Current WAS Removal Rate} \times \text{Current MLSS Concentration}) / (\text{Target MLSS Concentration})^{0.5}$$

The applied formula is semi-empirical and the square root factor is used to introduce a multi-step gradual adjustment of the sludge inventory. The new WAS removal rate was set manually by adjusting WAS pump discharge line valve position.

However, manually adjusting MLSS concentration through WAS control have proven to be difficult due to the significant variation of the MLSS and RAS concentrations of the grab



Fundamentals of Clarifier Performance Monitoring and Control

A SunCam online continuing education course

samples. MLSS grab sample collected anytime between 6 and 9 a.m. could vary by +/- 15 %, and the RAS concentration could vary by +/- 40%. Because of the large variation of grab sample values, the manual control of the activated sludge system solids inventory was not producing consistent nitrogen and phosphorus removal. In addition, the manual WAS control procedure required substantial operator time and, for practical reasons, could not be performed more than two times per day. Therefore, the plant staff began seeking a way to obtain real-time MLSS data, with the goal of automatically controlling MLSS through on-line instrumentation.

The first step in plant automation strategy was to install a solids concentration analyzer in one of the aeration basins. After being moved to several locations in the basin, the solids concentration analyzer was placed in the oxic zone of the aeration basin, 1.2 meters (4 feet) from the surface, far enough from excessive air turbulence but in a zone of mild agitation where minimum velocity of 0.6 m/sec (2 ft./sec) could be maintained across the probe. This location was found to be optimal in terms of fouling and needed frequency of analyzer probe cleaning. For several months, plant staff monitored actual MLSS using the on-line solids concentration analyzer, compared concentrations with the target MLSS and made manual WAS line valve adjustments.

After gaining comfort with the MLSS concentration analyzer, the staff discontinued daily grab sampling and lab analysis. The plant control system computer loop was modified to actuate the WAS flow valve eliminating the need for manual adjustment. Based on a target MLSS set by the plant staff, the solids concentration analyzer sends a signal to the WAS valve to adjust its position, allowing automated continuous WAS wasting and MLSS control.

Automated on-line solids concentration analysis and MLSS control has proven to be superior to manual control in maintaining MLSS in the aeration basins near target levels. After several months of testing, automated solids analyzers were installed in all seven active aeration basins and the entire plant was switched to automated MLSS control. Comparison of ammonia and phosphorus removal from total plant flow before and after implementing the automated MLSS control system shows improved plant performance, with ammonia and phosphorus levels well below permit limits.

As a further step towards improved plant performance, the plant staff replaced automated MLSS control with automated SRT control strategy, installing RAS concentration analyzers for all aeration basins. The SRT control strategy is better than targeting only constant MLSS control, particularly for situations in which extreme flow variations flush solids through the aeration basin. This control strategy aims to maintain target constant activated sludge SRT. The SRT is



Fundamentals of Clarifier Performance Monitoring and Control A SunCam online continuing education course

calculated as pounds of solids under aeration (based on automated MLSS concentration measurements), divided by pounds of solids wasted per day (based on automated RAS concentration measurements).

The experience at the Clark County wastewater treatment plant indicates that the use of on-line suspended solids analyzers can greatly enhance process control in activated sludge systems and improve the reliability of the biological nutrient removal processes. In addition, plant staff has determined that the overall costs of probe installation, operation and maintenance are significantly lower than manual sample collection, lab analysis and manual WAS control.

Sludge Blanket Depth Monitoring – Lumberton, Texas

At Lumberton No. 2 Wastewater Treatment Facility, Texas, located approximately 90 miles east of Houston, a sludge blanket meter was installed on the plant's primary clarifiers (Duncan, 2000). The clarifiers are circular tanks with unit volume of 1,120 cubic meters (295,000 gallons). The sludge blanket meter is suspended on a rod and is located just below clarifier's water level. The sludge blanket meter control unit is located near the meter sensor of the clarifier catwalk. The rod is hinged so that it does not interfere with the rotation of the clarifier rake mechanism.

The sludge blanket meter uses ultrasonic technology incorporating an ultrasonic transducer that continuously emits sonic pulses that are reflected in the form of echoes from the sludge blanket, thereby detecting the interface between light fluids and sludge. A built-in microprocessor digitally converts the round-trip time of each pulse and uses it to calculate distance. The dual-point unit can track levels and control sludge pump functions in the two clarifiers. Clarifier level readings are displayed numerically and can be sent directly to plant's control system. The sludge blanket depth monitoring unit also creates a composite graphic of the clarifier solids profile. Interlocking the sludge blanket depth monitoring unit with the primary sludge pump controls improved the clarifier performance and increased the average concentration of the sludge removed from the clarifiers from less than 1% to over 2 % solids.

Sludge Blanket Depth Monitoring – Ashbridges Bay Wastewater Treatment Plant, Toronto, Canada

The Toronto's 818,000 m³/day (180 MGD) Ashbridges Bay Wastewater Treatment Plant is the largest wastewater treatment facility in Canada (Fig 14). This plant successfully applied sludge blanket level detection equipment and radio technology system for automatic operation of the plant's primary clarifiers (Rudd et al., 2001). The Ashbridges Bay plant has moving bridge



Fundamentals of Clarifier Performance Monitoring and Control A SunCam online continuing education course

rectangular primary clarifiers. The clarifier control system uses ultrasonic sensors installed on the clarifiers' moving bridge.



Figure 14 – Areal View of Ashbridges Bay Wastewater Treatment Plant

The sludge blanket level system generates a graphical profile of the clarifiers' sludge blanket. The blanket level analyzer emits ultrasonic pulses at a frequency of four times per second. These pulses reflect from the various zones of solids concentration in the clarifier and are received by the instrument's detector. The sludge blanket instrumentation produces an echo profile of the clarifier sludge zones. The treatment plant operators use the clarifier sludge blanket profile to make process decisions.

Initially, the ultrasonic sludge blanket measurement system had occasional difficulties with accurately representing the sludge blanket profile due to off-gassing problems. Gasses generated in the clarifiers due to sludge septicity partially dissipated the ultrasonic sound of the instrumentation and thereby interfered with the normal operation of the sound detectors. Gas



Fundamentals of Clarifier Performance Monitoring and Control

A SunCam online continuing education course

bubbles also accumulated on the sensors surface disabling the instrument readings from time to time. The problem with gas bubble accumulation on the sensor was resolved by installing the instruments on a two to three-degree angle from the vertical direction. This allowed the bubbles to roll over the sensor surface while the tank bridge was moving.

The signal from the ultrasonic sludge detectors was emitted via radio modems to the plant control system allowing the plant operations staff to monitor the performance of the clarifier sludge collection and withdrawal equipment. This monitoring instrumentation also detected if the sludge collection mechanisms and sludge withdrawal pumps were functioning properly. In addition, the sludge blanket monitoring system optimized the performance of the plant solids handling system by maximizing the concentration of the primary sludge pumped to the anaerobic digesters. The average primary sludge concentration was increased from 0.5 % to 2 % solids through the implemented sludge inventory monitoring and control improvements.

5. References

Albertson, O. E. and T. Waltz (1997) Optimizing Primary Clarification and Thickening, Water Environment and Technology, December.

Bain, R. E. and W. S. Johnson (1988) Probing for Improved BNR, Automating Suspended Solids Control Helps a Plant Maintain Consistent Nutrient Removal, Operations Forum, February.

Burke, T., Hamilton, I. M. and E. J. Tomlinson (1985) Treatment Process Management and Control, Instrumentation & Control of Water & Wastewater Treatment and Transport Systems, Proceedings of the 4th IAWPRC Workshop, Houston & Denver.

Bush, D. (1991) Sludge Blanket Monitoring Improves Process Control, Cuts Costs, Water Engineering & Management, September.

Dakers, J. L. (1985) Automation and Monitoring of Small Sewage Treatment Works. Instrumentation & Control of Water & Wastewater Treatment and Transport Systems, Proceedings of the 4th IAWPRC Workshop, Houston & Denver.

Dartez, J. (1996) Return Activated Sludge Control, Water & Wastes Digest, May.

Duncan, D. (2000) Plant Automates Sludge Measurement in Clarifier, WaterWorld, February.



Fundamentals of Clarifier Performance Monitoring and Control A SunCam online continuing education course

Hoffman, C. G and H. M. Wexler (1996) A Progressive Approach to the Control of Return Sludge Pumping, Water Engineering & Management, February.

Hill, B., Manross B., Nutt, S., Davidson, E., Andrews, J., Haugh, R., Reich, R. (2001) WEFTEC 2001 Seminar #114, WERF: State-of-the-Art WWTP Sensing and Control Systems, Sunday, October 14, Atlanta, Georgia.

Hinton-Lever, A. (2000) Stable Mate for STW Bosses, Water & Waste Treatment, September, Vol. 43, Issue 9.

Exter, A. (1998) Automatic Waste Control, Machine Sampling, Calculations, and Adjustments Ensure Better Performance of Activated Sludge Systems, Water Environment & Technology, August.

Exter, A. (2000) Automatic Waste Control, Water 21, Magazine of the International Water Association, August.

Rudd, D., Alaica, J., Samules, C. and Geith, W. (2001) Canada's Largest Plant Uses Ultrasonic Detection and Digital Radio Technology, Environmental Science and Engineering, September.

Samuels, C. (2000) Control System Improved Activated Sludge And Sludge Thickening Process, Environmental Science and Engineering, November.

Water Environment Federation (1996), Manual of Practice 11, Operations of Municipal Wastewater Treatment Plants, Volume 1, Fifth Edition.

Wheeler, G. P., B.A. Hegg, and C. Walsh (2001), Capital Defense, Water Environment and Technology, September.

Wilkinson, J. Harry (1997), Continuous On-line Analyzers Can Help Operators Work More Efficiently, Operations Forum.