



A SunCam online continuing education course

What Every Engineer Should Know About Structures

Part D - Bending Strength Of Materials

by

Professor Patrick L. Glon, P.E.



What Every Engineer Should Know About Structures - Part D - Bending Strength of Materials
A SunCam online continuing education course

This is a continuation of a series of courses in the area of study of physics called engineering mechanics. This is a series of courses in Statics and Strength of Materials. This is the fourth course of the series and is called **What Every Engineer Should Know About Structures - Part D - Bending Strength of Materials**.

The study of **Strength of Materials** takes the step after Statics and focuses on solving problems dealing with the stresses within those members of a stationary body (beams, columns, cables, etc.). This series will provide the tools for solving some of the most common structural design and analysis problems. The focus will be on presenting simplified methods of solving problems.

This course includes:

- cross sectional properties of structural members including defining and determining the Moment of Inertia and Section Modulus of a cross section.
- torsional stresses and deformations of rods and shafts
- shear and bending moment diagrams of beams
- bending stresses in loaded beams
- shear stresses in loaded beams

This course is a continuation of the previous course **What Every Engineer Should Know About Structures - Part C - Axial Strength of Materials**. You should be familiar with the information presented in that course before proceeding with this course.



What Every Engineer Should Know About Structures - Part D - Bending Strength of Materials
A SunCam online continuing education course

WHAT IS STRENGTH OF MATERIALS

The study of **Strength of Materials** considers the internal forces in structural elements to determine:

- the stress and deformation within the member (stress analysis);
- the required size of the member to support the applied loads (design analysis); or
- the load carrying capacity of a structural system or member (load analysis).

Strength of materials follow statics. In statics, the structural elements are assumed to be perfectly rigid and to have unlimited strength. In real life, materials are not rigid. Materials supporting external loads stretch, bend, and shorten; they get thinner or fatter; and they twist, and undergo other deformations. And, of course, all materials do have an upper limit on their strength and they fail when they reach that limit.

The previous course in this series of courses concluded with the discussion of the centroid (C), or, center of gravity (c.g.), of a cross section. We will continue the discussion of properties of cross sections by taking a look at the moment of inertia.

MOMENT OF INERTIA

The **moment of inertia** of a cross section of a beam is a measure of the stiffness of a beam. It is a cross sectional property that is inversely proportional to deflection in a beam. That is, as the moment of inertia of the cross section of a beam gets bigger, the deflection of the loaded beam gets smaller. The moment of inertia is sometimes referred to by others as the *second moment of area*, *area moment of inertia*, *rectangular moment of inertia*, and, in cases of torsion, *polar moment of inertia*. Even though the second moment of area is probably a better description of what it actually is, we will use the term **moment of inertia** for all beam calculations. And for torsion of rods, we will use the term **polar moment of inertia**.

Moment of Inertia about the Centroidal Axis

The **centroidal axis** is the x-axis and the y-axis of the cross section that pass through the centroid (C), or center of gravity (c.g.), of the shape. The moment of inertia about either of the centroidal axis of a cross section is a section property that can be used to compare different cross sections of beams in an "apples to apples" sort of way. The moment of inertia is a common denominator. In a design problem, the moment of inertia can be used to compare different shaped beams to select the most efficient shape to meet the design criteria. Based on the shape of a beam cross section, a beam with less

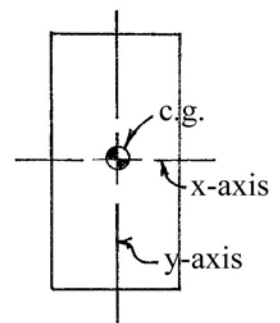



What Every Engineer Should Know About Structures - Part D - Bending Strength of Materials
A SunCam online continuing education course

material can be much stiffer, i.e., have a greater moment of inertia, than a beam with more material. And less material often means less cost.

Beams are typically shaped to produce high values for the moment of inertia to keep deflections under load to a minimum. The total material of the cross section is distributed in such a way as to produce a high moment of inertia about the center of gravity, or centroid. As we get a bit farther along in the discussion of the moment of inertia, it will become apparent that the more of the material of the cross section that can be placed far away from the centroid of the cross section, the higher the moment of inertia of the cross section about the centroidal axis becomes. A memory tip that I shared with students in class comes to mind - **"Lot's of material far away from the centroidal axis."**

Definition

The moment of inertia of a cross section about the centroidal axis is denoted by the symbol the capital letter "I". The moment of inertia is defined as:

The sum of the second moment of area of all the infinitesimally small areas of the cross section about the centroidal axis of the cross section.

That is, multiply each infinitesimally small area by the square of its distance from the centroidal axis of the cross section, and sum them.

Alert: We are now going to spend about one page of text using calculus for the derivation of one formula for the moment of inertia. If you are not familiar with calculus, don't worry about it. Just know that there is a simple and logical method to determining the equations for the moment of inertia of a cross section. If you are familiar with calculus, enjoy reviewing a simple application of the wonderful math invented by Sir Isaac Newton. With a nod to Gottfried Leibniz, who at around the same time in the 1670's, also came upon some of the same concepts. Two brilliant men! By the way, Newton is my favorite because he applied the math to physics. Which is what got us here today.

Derivation of the Moment of Inertia for a Rectangular Cross Section

In the language of calculus, an infinitesimally small area is denoted as dA . The distance from that area to the centroidal x-axis is y . Since I equals the sum of all the tiny areas multiplied by their distance squared, $I = \Sigma(y^2 \cdot dA)$. The integral is the tool used to sum all of these areas over the entire cross sectional area.

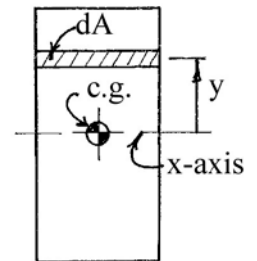

$$I = \int y^2 \cdot dA$$



What Every Engineer Should Know About Structures - Part D - Bending Strength of Materials
A SunCam online continuing education course

Solve for a Rectangle

For the special case of a rectangular cross section with its long dimension vertical, the drawing shows all of the terms, dimensions, and relationships necessary to solve the integral for the moment of inertia about the centroidal x-axis. Notice that the width of the cross section is b , and the total height is h . We will sum the products of the second moment of area of all the small areas from the bottom of the rectangle to the top. Over the range from $-h/2$ to $+h/2$.

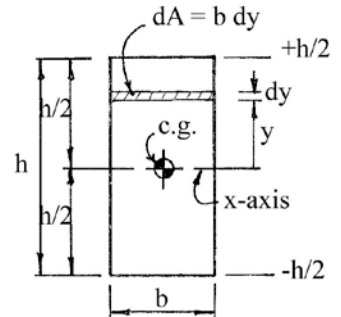

In the drawing, y is the distance from the centroidal axis to the infinitesimally small area. And, the infinitesimally small area, dA , is the thin strip parallel to the centroidal axis. The area of the thin strip is its width, b , times its height, dy .

$$dA = b \cdot dy$$

Substituting these values into the integral and solving

$$I = \int_{-h/2}^{+h/2} y^2 \cdot dA = \int_{-h/2}^{+h/2} y^2 (b \cdot dy)$$

In a rectangle, the width of the cross section, b , is a constant, so it can be pulled out of the integral. The integral can then be solved as follows:

$$I = b \int_{-h/2}^{+h/2} y^2 dy = b \left[\frac{y^3}{3} \right]_{-h/2}^{+h/2}$$

Next substitute the limits for y (y goes from $-h/2$ to $+h/2$) and complete the solution, as follows

$$I = b \left[\frac{(+h/2)^3}{3} - \frac{(-h/2)^3}{3} \right] = b \left[\frac{h^3}{24} - \frac{(-h)^3}{24} \right] = b \left[\frac{2h^3}{24} \right] = \frac{bh^3}{12}$$

This formula, $\frac{bh^3}{12}$, is the value of the moment of inertia of a rectangular cross section about its centroidal x-axis. Where the width of the cross section is b , and the height of the cross section is h . The units for the moment of inertia are in^4 . Reference books and other handbooks, list this formula for I of a rectangle.



And that's it - the end of calculus for this course.



What Every Engineer Should Know About Structures - Part D - Bending Strength of Materials
A SunCam online continuing education course

Other Special Areas

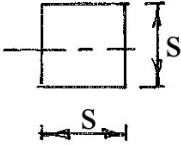
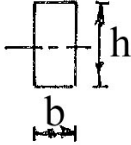
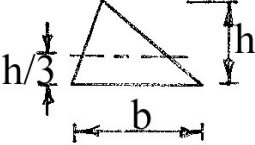
Some other special areas, in addition to the rectangle, have relatively simple formulas for the value of their moment of inertia about their centroidal axis. These formulas are also listed in reference books and handbooks. Some common areas, and their formulas, are shown below.

				
Square	Rectangle	Triangle	Circle	Hollow tube
$A = s^2$	$A = bh$	$A = \frac{bh}{2}$	$A = \frac{\pi D^2}{4} = \pi R^2$	$A = \frac{\pi(D^2 - d^2)}{4}$
$I = \frac{s^4}{12}$	$I = \frac{bh^3}{12}$	$I = \frac{bh^3}{36}$	$I = \frac{\pi D^4}{64}$	$I = \frac{\pi(D^4 - d^4)}{64}$

Example

What is the moment of inertia about the centroidal x-axis (I_x) of a beam with a rectangular cross section 2" wide by 4" high?

Solution

$$I_x = \frac{bh^3}{12} = \frac{(2 \text{ in}) \cdot (4 \text{ in})^3}{12} = 10.7 \text{ in}^4$$

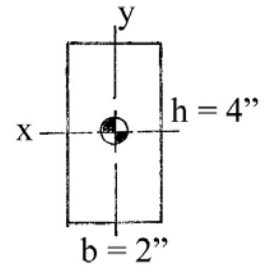

Another Example

Just for fun, what is the moment of inertia of the 2" x 4" beam above about the centroidal y-axis? HINT: Try rotating the page 90° and looking at the above drawing. The cross section has not changed shape or area. To use the formula for I of a rectangle, b is always the dimension along the axis about which the moment of inertia is wanted (the "width"). And h is always the dimension perpendicular to that axis (the "height"). The previous y-axis is now horizontal and the width is 4 inches. The previous x-axis is now vertical and the height is 2 inches.

Solution

$$I_y = \frac{bh^3}{12} = \frac{(4 \text{ in}) \cdot (2 \text{ in})^3}{12} = 2.7 \text{ in}^4$$

Remember, the moment of inertia is a measure of the stiffness of a beam - a bigger I means a stiffer beam and a smaller deflection. Here are two ways to look at this concept.

First, by the two calculations. The beam is stiffer about the x-axis than it is about the y-axis because I_x is larger than I_y (10.7 in^4 vs. 2.7 in^4). Therefore there will be less deflection of a loaded beam about the x-axis than there will be about the y-axis.



What Every Engineer Should Know About Structures - Part D - Bending Strength of Materials
A SunCam online continuing education course

And, second, by example. Imagine in your mind that you have an eight foot long piece of lumber that is a full 2" x 4" in cross sectional area. Take the 2" x 4" board and lay it flat, supported by two small blocks about 3 inches tall, one at each end of the beam. This makes a 4 inch wide by 2 inch high by 8 foot long beam that is now supported at its ends three inches above the floor. It is a balance beam that many of us had as kids. (The left drawing below).

Imagine now that you stand in the center of the beam. The beam will deflect downward. It will sag in the middle under your weight. The total sag will be in the range of about an inch, or so. Maybe less. Now, if you simply turn the 2 x 4 on edge so that the 4" dimension is the height of the beam and the 2" dimension is the width of the beam (the right drawing below) and stand on it again in the center, what do you think will happen to the deflection? Right, the deflection will be less. Just as the comparison of the moments of inertia about the x- and y- axis showed above. In fact, the deflection might so small that it would be difficult to measure. **Caution:** If you try this at home be very careful! The 2 x 4 on edge will develop compressive stresses in the top flange and will probably buckle, causing the 2 x 4 to roll over. You will fall off and could hurt yourself. Later in this course we will see how to calculate those compressive stresses in the top flange. I can't wait. Can you? And, in the next course of this series, we will calculate the deflections and also discuss the concept of buckling of the top flange.



Again, notice that there is no more or less total material in the 2" x 4" either way it is placed on the blocks. The only thing that changes is the axis about which the beam deflects. When on edge, it deflects about the x-axis. When laying flat, it deflects about the original y-axis. The moment of inertia of a cross section about its centroidal axis is a very important concept. It is a function of the shape of the cross section only. Nothing else.

The example above also demonstrates that beams become stiffer - i.e., has a higher moment of inertia - when more material is placed farther away from the centroidal axis in the direction of bending. The 2" x 4" flat has material only 1" above and below the neutral axis. The 2" x 4" on edge has material 2" above and below the neutral axis.

Parallel Axis Theorem

When a cross section of a member is composed of several parts whose centroidal axes do not coincide with the centroidal axis of the complete section, the **parallel axis theorem** must be used to compute the I of the complete section. You cannot simply sum the individual I's of the several parts.



What Every Engineer Should Know About Structures - Part D - Bending Strength of Materials
A SunCam online continuing education course

We will first use the parallel axis theorem to calculate the moment of inertia of a cross section about an axis that is parallel to, but not through, the centroidal axis of the cross section. The moment of inertia of a cross section is usually known about its own centroidal axis. Once that is known, it is then easy to calculate the moment of inertia of that cross section about an axis that is parallel to the centroidal axis.

If $I_{\bar{x}}$ is the moment of inertia of an area (A) about its own centroidal axis $\bar{x} - \bar{x}$, then for any parallel axis $x - x$ a distance d away from $\bar{x} - \bar{x}$, the moment of inertia, I_x is given by the formula:

$$I_x = I_{\bar{x}} + Ad^2$$

Where d is the distance from the centroidal axis of the cross section to the parallel axis about which the moment of inertia is wanted.

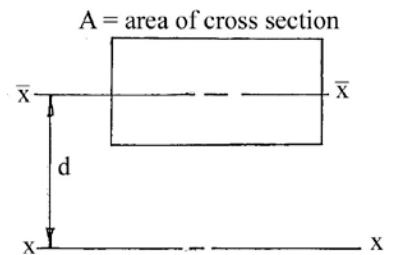

Example

What is the moment of inertia about the $x - x$ axis of a beam with a rectangular cross section 4" wide by 2" high as shown in the drawing?

Solution

$$I_x = I_{\bar{x}} + Ad^2 = \frac{bh^3}{12} + Ad^2$$

$$I_x = \frac{(4)(2)^3}{12} + (4 \times 2)(3)^2$$

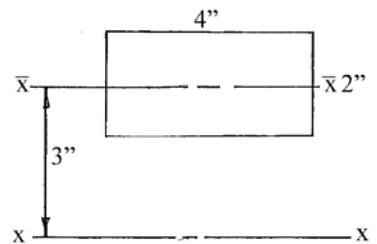

$$I_x = 2.6667 + 72 = 74.6667 \Rightarrow I_x = 74.7 \text{ in}^4$$

Example

What is the centroidal moment of inertia of the cross section to the right? The cross section consists of a Tee with a circular hole in the stem of the section as shown.

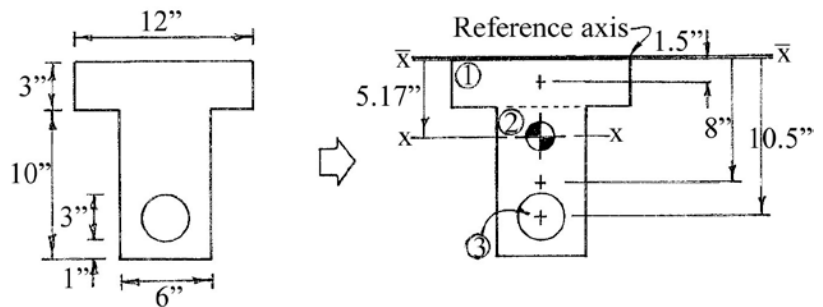

Solution

The solution is a two step process.

First, using the procedure presented in the previous course, determine the location of the centroidal axis of the entire cross section. Then, second, calculate the moment of inertia of the cross section about the centroidal axis.

First locate the centroidal axis of the entire cross section. Because the cross section is symmetrical about the y -axis, we know the centroid of the section lies somewhere along the y -



What Every Engineer Should Know About Structures - Part D - Bending Strength of Materials
A SunCam online continuing education course

axis. The issue at hand is to determine where along that axis it lies. Begin by establishing the reference axis (axis $\bar{x} - \bar{x}$) as the axis parallel to the centroidal axis. This time we will choose to locate the reference axis at the top of the cross section. Then, using a table format, find the location of the centroidal axis x-x of the entire cross section.

Area	A	y	Ay
1	36	1.5	54
2	60	8	480
3	-7.1	10.5	-74.6
Sum = 88.9			Sum = 459.4

$$\bar{y} = \frac{459.4}{88.9} = 5.17''$$

The centroidal axis of the entire cross section is located along the y-axis a distance of 5.17" from the reference axis as shown in the drawing to the right.

Second, using the parallel axis theorem, determine the moment of inertia of the cross section about the centroidal x - x axis. Use a table format for the calculations.

The moment of inertia of the entire cross section (I_x) about the x - x axis is given by the formula $I_x = \Sigma(I_{\bar{x}} + Ad^2)$. The moment of inertia of a rectangle is $I_{\bar{x}} = \frac{(b)(h)^3}{12}$, and the moment of inertia of a circle is $I_{\bar{x}} = \frac{(\pi)D^4}{64}$. The circle area and $I_{\bar{x}}$ of the circle will be negative because it is a hole in the cross section.

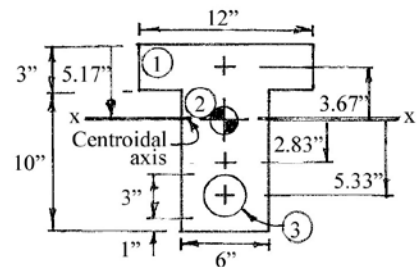

We will make the calculations using a table format to keep the calculation simple and easy to follow. Also notice that the starting dimensions and distances from the centroidal axis are also included in the table - again for simplicity and ease of calculation.

Moment of Inertia about Centroidal Axis							
Area	b	h	D	$I_{\bar{x}}$	A	d	Ad^2
1	12	3	-	27	36	3.67	484.9
2	6	10	-	500	60	2.83	480.5
3	-	-	3	-4	-7.07	5.33	-200.9
				523			764.5

$$I_x = \Sigma(I_{\bar{x}} + Ad^2)$$

$$I_x = 523 + 764.5 = 1,287.5$$

$$I_x = 1,290 \text{ in}^4$$



What Every Engineer Should Know About Structures - Part D - Bending Strength of Materials
A SunCam online continuing education course

This method of computing the moment of inertia of a cross section about the centroidal axis can be quite tedious for cross sections that are not "regular". For example, those cross sections with rounded corners, varying thicknesses of a flange or web, and odd shapes such as structural steel angles and channels. Fortunately for us, in practice, the process of determining the moment of inertia on commonly used steel and wood members is relatively quick and easy. Handbooks and reference tables list the locations of the centroids of the cross sections, the area of the cross sections, and the moments of inertia about the x-axis and y-axis.

The drawings and table below show a couple of different steel shapes along with the location of their centroids - both the x-axis and the y-axis.

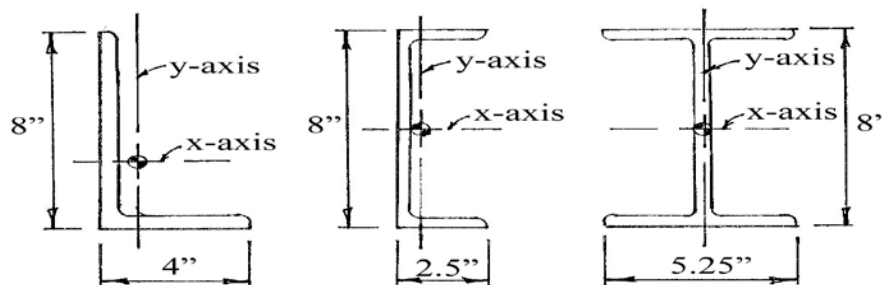

Shape	L8x4x1/2	C8x18.75	W8x18
Wt (#/ft)	19.6	18.75	18
A (in ²)	5.75	5.51	5.26
I _x (in ⁴)	38.5	44.0	61.9
I _y (in ⁴)	6.74	1.98	7.97

Notice a couple of things about the three sections shown above. First, they all have the same height - 8 inches. They all have approximately the same cross sectional area - 5.26 in² to 5.75 in². And, therefore, all weigh about the same - 18 #/ft to 19.6 #/ft. Steel is purchased primarily by weight so each member of the same length will cost approximately the same amount.

Now look at the moments of inertia about the x-axis, the "strong" axis. There is a tremendous difference between the smallest and the largest. The lightest section, and therefore the cheapest to purchase, has by far the highest moment of inertia - 61.9 in⁴. While the heaviest section, and therefore the most expensive to purchase, has the smallest moment of inertia about the x-axis - 38.5 in⁴. So, if your design criteria is governed by the moment of inertia, you would select the lightest member that meets the criteria.

The moment of inertia of a beam is determined solely by the placement of the material within the cross section. To make a beam strong in bending, i.e., having a high moment of inertia, place more material farther away from the centroidal axis.



What Every Engineer Should Know About Structures - Part D - Bending Strength of Materials
A SunCam online continuing education course

The drawing and table below are for common wood members.

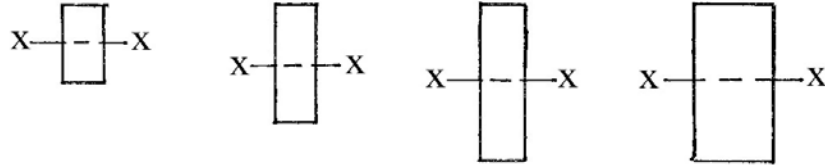

Nominal Size	2 x 4	2 x 6	2 x 8	4 x 8
Actual Size (in)	1.5 x 3.5	1.5 x 5.5	1.5 x 7.25	3.5 x 7.25
Area (in ²)	5.25	8.25	10.9	25.4
I _x (in ⁴)	5.36	20.8	47.6	111

Notice how rapidly the moment of inertia increases for a slight increase in depth. That's because the moment of inertia is most influenced by the depth of the member - the depth cubed. The moment of inertia of a 2 x 6 is roughly four times that of a 2 x 4. Comparing the 2 x 8 with the 4 x 8 shows a slightly more than doubling of the moment of inertia. That makes sense because the depth is the same but the width is slightly more than doubled.

TORSION

We will now consider a torsional loading on a straight, circular member. The simplest illustration of torsion on a member is a wrench applying torque to a bolt. Or turning a wheel with both hands. The wheel could be connected to a shaft to steer a vehicle, or perhaps to a shaft that closes a valve.

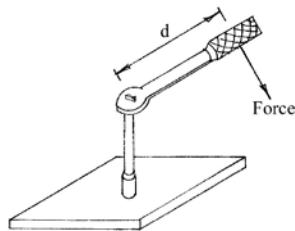

Torque
 $M = F \times d$

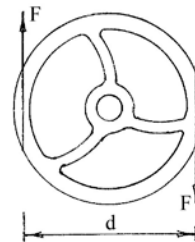

Couple
 $M = F \times d$

Torsional loading causes a member to twist or to rotate. Torsional loading is a form of axial load. A torsional loading is called **torque, rotational moment, twisting moment, or couple**. When torque is applied to a member, the member will experience shearing stress and torsional deformation. Torsional deformation is a rotation of one end of the member relative to the other end of the member.



What Every Engineer Should Know About Structures - Part D - Bending Strength of Materials
A SunCam online continuing education course

Torque

Torque is defined as a force times a distance. In the case of a wrench, or other similar loading condition, there is one force acting at a distance, d , from the shaft. The torque (rotational moment or twisting moment) is defined as the force times the distance. The units of torque are lb-ft or lb-in, or Newton-meters (N-m).

$$M = F \cdot d$$

In the case of the wheel, there are two equal forces acting in opposite directions, and are separated by a distance, d , apart. This situation is called a **couple** and the torque (rotational moment or twisting moment) on the attached shaft is defined as the force times the distance between them.

$$M = F \cdot d$$

Example

What is the moment delivered to the shaft by the socket wrench above if the force applied to the wrench is 65 pounds and the wrench is 10 inches long?

Solution

$$M = F \cdot d = (65 \#) \cdot (10 \text{ in}) = 650 \text{ lb} - \text{in} = 54.2 \text{ lb} - \text{ft}$$

Example

What is the moment delivered to the shaft by the wheel above if each hand applies a force of 40 pounds to the wheel (in opposite directions, one up and one down, and which turns the wheel clockwise), and the wheel has a diameter of 16 inches?

Solution

$$M = F \cdot d = (40 \text{ lb}) \cdot (16 \text{ in}) = 640 \text{ lb} - \text{in} = 53.3 \text{ lb} - \text{ft}$$

Torsional Shear Stress

When an externally applied torque or couple is applied to a round shaft, an internal resisting torque must be developed in the shaft. This internal resisting torque is called **torsional shear stress**. The figure shows a round shaft subjected to torque. One end of the shaft rotates relative to the other end. If an infinitesimally small element on the surface of the bar were isolated, it would have shear stresses on the sides parallel to the ends of the bar. For the element to be in equilibrium, equal and opposite shearing stresses would exist on the top and bottom faces of the element as shown. The torsional shear stress is the same as direct shear stress when a small element is considered.

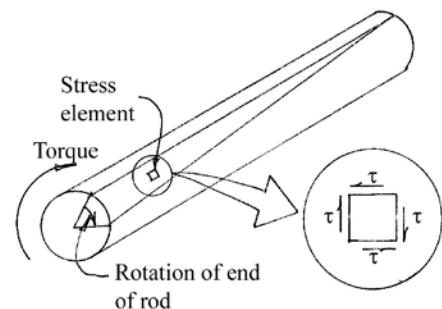



What Every Engineer Should Know About Structures - Part D - Bending Strength of Materials
A SunCam online continuing education course

The torsional shear stress varies throughout the cross section of a rod in torsion. There is no shear stress (torsional shear stress equals zero) at the center of a round cross section. The shear stress varies along the radius as the distance from the center to the surface of the rod increases. At the surface of the rod, the torsional shear stress is maximum. The variance is a straight line, or linear. At half the distance from the center of the rod to the surface of the rod, the torsional shear stress is half the maximum.

Formula for Torsional Shear Stress

Torsional shear stress is identified by the small Greek letter tau, (τ). The **general formula for torsional shear stress** is:

$$\tau = \frac{Tr}{J}$$

Where T is the applied torque, r is the distance from the center of a round rod to where the stress is wanted, and J is the **polar moment of inertia**

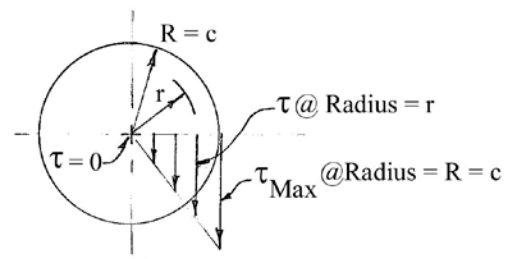

The polar moment of inertia is derived by using calculus. For a solid round bar of diameter D, the polar moment of inertia is given by the formula

$$J = \frac{\pi D^4}{32}$$

And the **maximum torsional shear stress** in a solid round bar of radius c, is given by the formula

$$\tau_{max} = \frac{Tc}{J}$$

Example

What is the maximum torsional shear stress in a 2 inch diameter rod subjected to a torque of 1,000 lb-in?

Solution

The maximum torsional shear stress of a solid round bar is given by the formula $\tau_{max} = \frac{Tc}{J}$ where c equals the radius of the bar (1 inch), T equals the applied torque (1,000 lb-in), and J equals the **polar moment of inertia** of the bar, calculated as follows.

$$J = \frac{\pi D^4}{32} = \frac{\pi(2)^4}{32} = 1.5708 \text{ in}^4$$

and then,

$$\tau_{max} = \frac{Tc}{J} = \frac{(1,000 \text{ lb} - \text{in})(1 \text{ in})}{1.5708 \text{ in}^4} = 636.62 \text{ psi} \Rightarrow 637 \text{ psi} = 0.637 \text{ ksi}$$



What Every Engineer Should Know About Structures - Part D - Bending Strength of Materials
A SunCam online continuing education course

What would happen to the maximum torsional shear stress if the bar were only a quarter of an inch larger (about 12%) in diameter? (That's about a 25% increase in area, and therefore, about a 25% increase in cost.) Let's see. For this case, $D = 2.25$ inch and $c = 1.125$ inch.

$$J = \frac{\pi D^4}{32} = \frac{\pi(2.25 \text{ in})^4}{32} = 2.5161 \text{ in}^4$$

Then,

$$\tau_{max} = \frac{Tc}{J} = \frac{(1,000 \text{ lb-in})(1.125 \text{ in})}{2.5161 \text{ in}^4} = 447.12 \text{ psi} \Rightarrow 447 \text{ psi} = 0.447 \text{ ksi}$$

We see that the maximum torsional shear stress is reduced by about 30% for about a 25% increase in cost.

This makes sense. A larger diameter bar is stronger than a smaller diameter bar. Again, more material farther from the centroid.

Of course, the torque on the bar also influences the value of the torsional shear stress in a one-to-one fashion. Double the torque and it doubles the torsional shear stress, halve the torque and it halves the torsional shear stress.

Angle of Twist

A bar fixed at one end, with an applied torque at the other end, will rotate (or twist) between the two ends through an angle θ as shown in the drawing. Note that the drawing greatly exaggerates the angle of rotation.

Let's derive the formula for angle of twist of a bar subjected to a torque or couple. For a straight round bar of length L , and an applied torque T , the shaft will rotate between the two ends through an angle. As the torque is applied, the surface of the bar along the long dimension will rotate through a small angle represented by the small Greek letter gamma (γ). Also, a radius on the cross section of the bar will rotate through an angle θ .

Both rotations - γ and θ - are related to the arc length CD along the surface of the bar. Using geometry of small angles, the arc length CD is the product of the angle in radians times the distance from the center of rotation. The center of rotation for γ is the end at A and the distance from the center of rotation is L . The center of rotation for θ is the center of the cross section at B and the distance from the center of its rotation is the radius of the bar c .

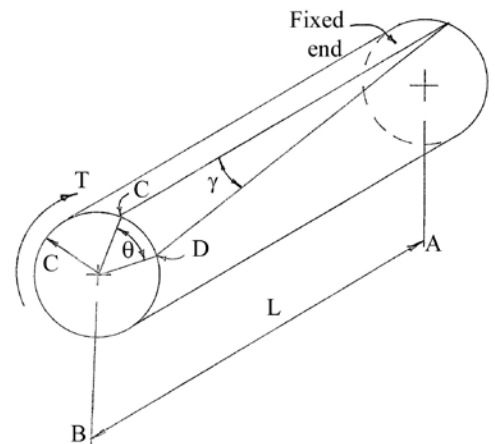



What Every Engineer Should Know About Structures - Part D - Bending Strength of Materials
A SunCam online continuing education course

Therefore, length CD can be expressed in terms of both γ and θ as $CD = \gamma L$, and $CD = \theta c$.
Setting these two equal to each other gives $\gamma L = \theta c$.

Solving for gamma gives,

$$\gamma = \frac{\theta c}{L}$$

Gamma is a measure of the maximum shearing strain of an element at the outer surface of the bar. We know that stress is related to strain by the modulus of elasticity. For rotational stress and strain, the modulus of elasticity in shear is G.

$$G = \frac{\text{stress}}{\text{strain}} = \frac{\tau}{\gamma}$$

At the outer surface of the rod, then,

$$\tau = G\gamma$$

But the torsional shear formula from above states,

$$\tau = \frac{Tc}{J}$$

Equating these two formulas gives,

$$\frac{Tc}{J} = G\gamma$$

Now, from above, substitute for $\gamma = \frac{\theta c}{L}$, and you get,

$$\frac{Tc}{J} = G \cdot \frac{\theta c}{L}$$

Cancel c, and solve for θ ,

$$\theta = \frac{TL}{JG}$$

The rotation of a shaft subjected to applied torque can now be calculated. The angle θ is in radians. When using consistent units for T, L, J, and G, all units will cancel, leaving a pure number in radians. Also, remember that $\pi \text{ rad} = 180^\circ$. Or, 1 radian = $(180 / \pi)$ degrees.

A large percentage of torsional rods are made of steel or some other metal alloy. Following is a listing of the modulus of elasticity in shear, G, for a few materials.



What Every Engineer Should Know About Structures - Part D - Bending Strength of Materials
A SunCam online continuing education course

Shear Modulus of Elasticity, G	
Material	psi
Plain carbon and alloy steels	11.5×10^6
Stainless steel type 304	10.0×10^6
Aluminum 6061-T6	3.75×10^6
Beryllium copper	7.0×10^6
Magnesium	2.4×10^6
Titanium alloy	6.2×10^6

Example

A 1/2 inch diameter, three foot long, plain carbon steel rod is subjected to a 10 lb-ft torque. What is the maximum twist, in degrees, of the rod?

Solution

The maximum twist is given by the formula = $\frac{TL}{JG}$.

The torsional moment of inertia of the rod is $J = \frac{\pi D^4}{32} = \frac{\pi (\frac{1}{2} \text{in})^4}{32} = 0.0061359 \text{ in}^4$

And,

$$\theta = \frac{TL}{JG} = \frac{[(10 \text{ lb} - \text{ft}) (\frac{12 \text{ in}}{1 \text{ ft}})] [(3 \text{ ft}) (\frac{12 \text{ in}}{1 \text{ ft}})]}{(0.0061359 \text{ in}^4) (11.5 \times 10^6 \text{ lb/in}^2)} = 0.061222 \text{ radians}$$

Converting radians to degrees.

$$0.061222 \text{ radians} \left(\frac{180 \text{ degrees}}{\pi \text{ radians}} \right) = 3.508 \text{ degrees} \Rightarrow 3.51 \text{ degrees}$$

BEAMS

Our next area of study will be beams, and the forces within them. We will confine ourselves to **simple beams** - horizontal beams that support vertical loads. And, of course, no friction, perfectly straight, precise loads values, point loads acting at a point, etc. - all the stuff necessary to make the calculations simple and the answer correct to within three significant figures.

Note: If you're not sure about loads and supports for beams, download the free SunCam review course titled **Loads, Supports, and Assumptions - A Quick Review**.



What Every Engineer Should Know About Structures - Part D - Bending Strength of Materials
A SunCam online continuing education course

Loads, Supports, and Assumptions – A Quick Review is a zero credit course intended for those who might find themselves a bit rusty and would like a quick refresher. The information in the course is useful for application to solutions of structural problems.

This course is free and can be downloaded by clicking the link below.

<http://www.suncam.com/authors/123Glon/supports.pdf>

This may seem to be a restrictive view of beams. However, most beams fall under these parameters. The following discussion covers almost all - certainly the vast majority - of beams in use today.

Internal Forces in a Beam

When a beam has a load applied to it, the external forces must be in equilibrium to allow the reactions to be computed. To transfer the loads from the point of application to the supports, the beam must develop internal forces. These internal forces must also be in equilibrium with the external forces.

We can look at the internal forces in a beam by cutting the beam with an imaginary plane that is perpendicular to the long axis (called the neutral axis) of the beam. The internal forces can be examined at this cut surface.

Theoretically, there could be six different forces acting at a cut surface – three axial forces - one along each of the three-dimensional axis - (F_x , F_y and F_z), and three moments - one in each of the three planes of the three dimensional axis - (M_{xy} , M_{xz} and M_{yz}). Since we are only considering the beam in two dimensions - vertical and horizontal - two of the forces, F_z and M_{xz} , do not exist because they are concerned with bending of a beam about the minor axis. Also, since the loads are only vertical, there is no F_x force. Nor is there torsion in the beam. This leaves only two forces, F_y (the vertical loads), and M_{xy} (the moment in the x-y plane), as the internal forces in an ordinary beam - a simple beam. The force F_y is called **shear** and is identified by the letter “**V**”. The moment M_{xy} is called **bending moment** or simply **moment**, and is identified by the letter “**M**”.

The drawing shows the forces in a beam that has been cut at a distance “a” from the left support. The beam is loaded with a load at a distance “b” from the cut. The cut is made at point “o” in the beam - a point along the neutral axis (n.a.) of the beam. Although two free-body sections are shown, one on each side of the cut, it is normally only the left free-body section that is shown and used.

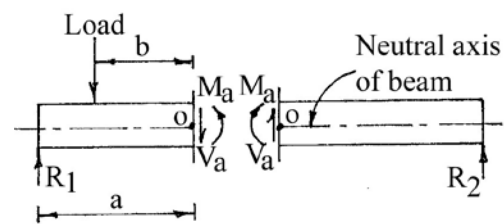

Internal Forces in a Simple Beam



What Every Engineer Should Know About Structures - Part D - Bending Strength of Materials
A SunCam online continuing education course

The internal forces (shear and moment) at the cut surface must be replaced by external forces. In this case, the internal forces are labeled V_a and M_a . Notice that the forces are equal and opposite on the two faces. The shear and moment are shown with the arrows in a positive direction. Because the internal forces are in equilibrium with the external forces, the magnitudes of V_a and M_a can be calculated.

Shear

Shear is an internal force in which two adjacent sections of the beam try to slip by each other. It is represented by the force V_a in the above drawing. The shear is determined by summing forces on the free body diagram that are perpendicular to the n.a. (neutral axis) of the beam. The units for shear are force – pounds, kips or kilonewtons.

The **shear sign convention** is shown below. Positive shear is produced by external or internal forces that act up on the left end of the cut beam section of the beam, and down on the right end of the cut beam section. Negative shear acts in the opposite direction.

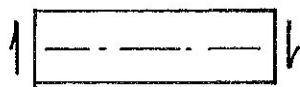

Positive Shear

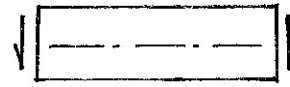

Negative Shear

Shear Sign Convention

Bending Moment

Bending moment is an internal force in which the fibers above (or below) the neutral axis of a beam are in compression and the fibers on the other side of the neutral axis are in tension. It is represented by M_a as shown previously. The bending moment is determined by summing moments about any point on the neutral axis of the free-body diagram - however, the point at the cut surface, Point O in the previous drawing, happens to be the best choice. The units for moment are force times distance – pound-feet, kip-feet or kilonewton-meters.

The **bending moment sign convention** is shown in the drawing. Positive bending moment exists when the top fibers of a beam are in compression and the bottom fibers are in tension. Think of it as a beam that bends in a shape that will contain water. If the tension and compression are reversed - i.e., tension in the top and compression in the bottom - it is called a negative bending moment. This is the sign convention we will use in this course. There are other sign conventions for moment that are used by other structural engineers.

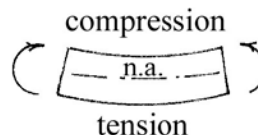

Positive Moment

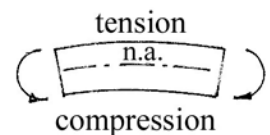

Negative Moment

Moment Sign Convention



What Every Engineer Should Know About Structures - Part D - Bending Strength of Materials
A SunCam online continuing education course

Shear and Moment at a Point

To determine the shear and / or moment at any location along the axis of a beam, cut the beam at that point and create a free-body of the section of beam to the left of the cut surface. Include all dimensions, and all external loads, reactions and moments that occur within that section of beam. Label the unknown shear and moment at the cut face. Solve for the shear by summing forces vertically, and solve for the moment by computing moments.

Example

Determine the shear and moment in the beam at mid-span.

Solution

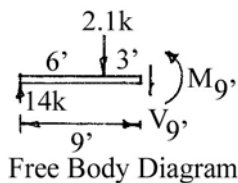
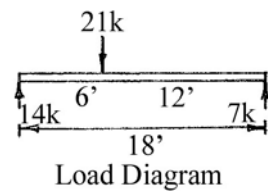

$$\sum F_y = 0$$

↑	↓
14	21
	V_9

$$14 = V_9 + 21$$

$$V_9 = -7 \downarrow$$

$$V_9 = 7 \text{ kips } \uparrow$$

$$\sum M @ 9' = 0$$

↺	↻
(21) (3)	(14) (9)
M_9	

$$M_9 + 63 = 126$$

$$M_9 = 63 \text{ kip-ft } \curvearrowright$$

Shear and Moment at Regular Intervals

It turns out that the value of the shear and moment in a beam varies along the beam in a pattern. This can be shown by computing the shear and moment in a beam at regular intervals along the neutral axis of a beam and plotting the results. The example below shows the calculations of shear and moment at 4 foot intervals along the length of the 20 foot beam that carries a load of 4 kips per foot.

Example

For the beam shown on the right, compute the shear forces and bending moments in the beam at 4-foot intervals, from 4' to 16' and plot the results on a shear diagram and a bending moment diagram.

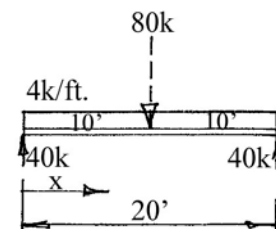



What Every Engineer Should Know About Structures - Part D - Bending Strength of Materials
A SunCam online continuing education course

Solution

At $x = 4$ feet from the left end:

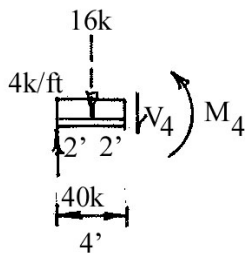

$$\sum F_v = 0$$

↑	↓
40	16
V ₄	
40 = V ₄ + 16	
V ₄ = 24 kips ↓	

$$\sum M @ 4' = 0$$

↺	↻
M ₄	(40) (4)
(16) (2)	
M ₄ + 32 = 160	
M ₄ = 128 kip-ft↻	

At $x = 8$ feet from the left end:

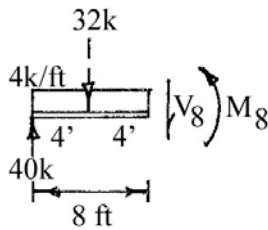

$$\sum F_v = 0$$

↑	↓
40	32
V ₈	
40 = V ₈ + 32	
V ₈ = 8 kips ↓	

$$\sum M @ 8' = 0$$

↺	↻
M ₈	(40) (8)
(32) (4)	
M ₈ + 128 = 320	
M ₈ = 192 kip-ft↻	

At $x = 12$ feet from the left end:

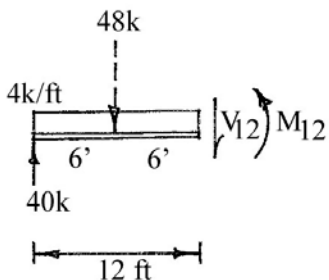

$$\sum F_v = 0$$

↑	↓
40	48
V ₁₂	
40 = V ₁₂ + 48	
V ₁₂ = - 8 kips ↓	
V ₁₂ = 8 kips ↑	

$$\sum M @ 12' = 0$$

↺	↻
M ₁₂	(40) (12)
(48) (6)	
M ₁₂ + 288 = 480	
M ₁₂ = 192 kip-ft↻	

At $x = 16$ feet from the left end:

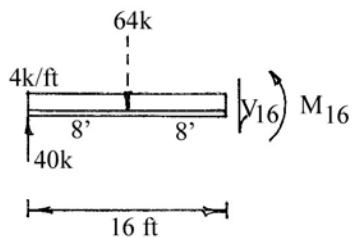

$$\sum F_v = 0$$

↑	↓
40	64
V ₁₆	
40 = V ₁₆ + 64	
V ₁₆ = - 24 kips ↓	
V ₁₆ = 24 kips ↑	

$$\sum M @ 16' = 0$$

↺	↻
M ₁₆	(40) (16)
(64) (8)	
M ₁₆ + 512 = 640	
M ₁₆ = 128 kip-ft↻	



What Every Engineer Should Know About Structures - Part D - Bending Strength of Materials
 A SunCam online continuing education course

Now, plot the values on a shear diagram and a bending moment diagram:

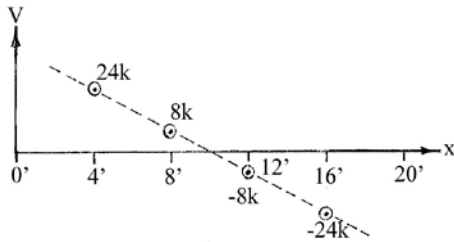

Shear

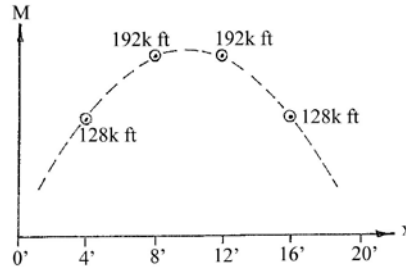

Bending Moment

Standard Beam Diagrams and Formulas

The idea of plotting shear and moment values as shown above can be expanded. Taking the concept farther, continuous lines can be drawn for both the shear diagram and the moment diagram. These two diagrams plus the load diagram are called **standard beam diagrams**. There are two additional diagrams, the rotation diagram and the deflection diagram, that are also part of the set, but we won't be studying them here.

The beam diagrams for a number of common support and load combinations have been solved and plotted, and are available in many technical publications. The commonly used reference with these standard beam diagrams is the AISC Steel Construction Handbook. A typical standard beam diagram is shown below. It is for a single span beam with a uniformly distributed load. The diagram and **beam formulas** below are similar to what will be shown in the AISC Steel Construction Handbook.

SIMPLE BEAM - UNIFORMLY DISTRIBUTED LOAD

$$\begin{aligned} \text{Total Equivalent Uniform Load} &= wl \\ R = V &= \frac{wl}{2} \\ V_x &= w\left(\frac{l}{2} - x\right) \\ M_{max.} \text{ (at center)} &= \frac{wl^2}{8} \\ M_x &= \frac{wx}{2} (l - x) \\ \Delta_{max.} \text{ (at center)} &= \frac{5wl^4}{384 EI} \\ \Delta_x &= \frac{wx}{24 EI} (l^3 - 2lx^2 + x^3) \end{aligned}$$

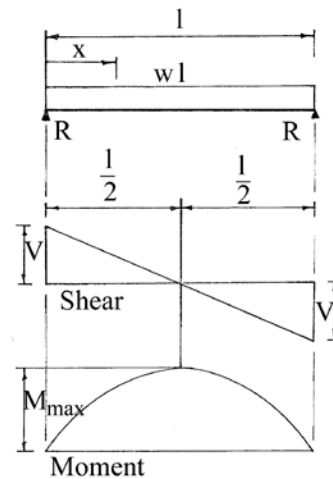



What Every Engineer Should Know About Structures - Part D - Bending Strength of Materials
A SunCam online continuing education course

Note that the load diagram is shown on top, the shear diagram is in the middle, and the moment diagram is shown on the bottom. Note also that the three diagrams line up vertically. This is the way beam diagrams are always shown!

Beam Formulas

The standard beam diagrams not only show the shape of the shear and moment diagrams, but they also have formulas for maximum values of shear and moment and for all intermediate values along the beam. These beam formulas can easily be derived if the loading is simple, as in the beam diagrams shown above, but they become awkward as the complexity of the loading diagram increases.

Notice that the maximum bending moment is shown at the center of the beam above - a simple beam with a uniformly distributed load. And that the formula for maximum bending moment from above is $M_{max}(at\ center) = \frac{wL^2}{8}$. This is the most useful of all formulas - the maximum bending moment for a uniformly loaded simple span. Note: Simple span simply means that it is a single span beam with pin supports. With this one exception, formulas given with the standard beam diagrams are usually ignored since there is a better way of computing the values of the maximum shear and bending moment in a beam. We create our own shear and bending moment diagrams. Here's how.

Creating Beam Diagrams

The sequence of the beam diagrams, from top to bottom, along with the units appropriate for each diagram is listed below.

<u>Diagram</u>	<u>American Units</u>	<u>SI Units</u>
Load (on top)	kips/ft	kN/m
Shear (in middle)	kips	kN
Moment (at bottom)	kip-ft	kN-m

There are a series of **beam diagram rules** that can be used to construct each of the diagrams of the beam diagram series. If you haven't seen these rules before, they are a lot easier to understand if you study the diagrams at the end of the rules while you study the rules for the first few times.

Except as noted, the following **rules for creating beam diagrams** apply to all diagrams. These rules, without a verbal explanation as we go along, can be confusing at first. After the rules are learned, they are fairly simple, easy, and quick to use. Again, there are several examples just after the rules that will help understand the rules as they are read the first time.

1. Each diagram is derived from the one above (with the exception of the load diagram).



What Every Engineer Should Know About Structures - Part D - Bending Strength of Materials
A SunCam online continuing education course

2. Draw the shear and moment diagrams by starting at the left end and progressing to the right. All diagrams begin and end at zero. If they don't end at zero, you've made a mistake!
3. The vertical change in value between two horizontal points is the area of the diagram above between those two points. If there is a concentrated value between those two points, it must be added to the area.
4. The slope of a line at any point is equal to the value of the diagram directly above.
5. The curvature of the lines increase by an order of one with each diagram.

No line	-
Horizontal line	0
Sloped line	1
Parabola	2
Cubic	3
6. A concentrated load or reaction causes a vertical offset in the shear diagram equal to the magnitude of the load. Upward reactions cause an upward offset, and downward loads cause a downward offset.
7. A concentrated moment causes a vertical offset in the moment diagram, but does not affect the shear diagram. Clockwise moments cause an upward offset, and counterclockwise moments cause a downward offset.
8. Points of zero shear must be indicated on the shear diagram. If they occur under a concentrated load no calculation is necessary. If not, that location must be calculated and shown on the diagram.
9. Points of zero shear are points of maximum moment on the moment diagram and the value of the moment at that point must be evaluated.
10. Draw diagrams to appropriate horizontal and vertical scales. Do NOT show the scales.
11. Align all diagrams vertically. Put all diagrams for a single problem on the same page.
12. Indicate all maximum values and breakpoint values. Indicate the units for all values. Use a minus sign for all negative values.
13. Be precise about drawing vertical, horizontal, sloped, curved lines, and points of tangency. Use a straightedge and a French curve.



What Every Engineer Should Know About Structures - Part D - Bending Strength of Materials
 A SunCam online continuing education course

Example

Draw the shear and moment diagrams for a simple beam with a uniform load.

Solution

Load Diagram Area of load diagram is -64 k (downward loads are minus).

Shear Diagram Start at left end, then straight up 32 k, then slope down at a rate of 4 kips/ft.

$$a = \frac{32 \text{ k (max shear)}}{4 \frac{\text{k}}{\text{ft}} (\text{load})} = 8 \text{ ft}$$

$$\text{area of diagram} = (.5) \cdot (32 \text{ k}) \cdot (8') = 128 \text{ k} \cdot \text{ft}$$

Moment Diagram Start at left end then curve up to a maximum of 128 k-ft then -128 k-ft to zero. Curve is a parabola with apex at center.

Remember a few pages back, we said that the most useful beam formula is $M_{max}(\text{at center}) = \frac{wL^2}{8}$, for the maximum moment for a uniformly loaded simple span? Well, let's see :

$$M_{max}(\text{at center}) = \frac{wL^2}{8} = \frac{(4 \text{ kips/ft}) \cdot (16 \text{ ft})^2}{8} = 128 \text{ kip} \cdot \text{ft} \text{ check } \checkmark \odot$$

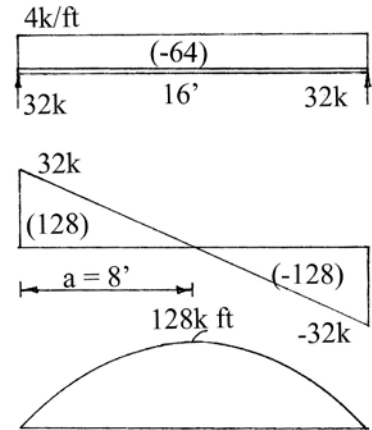

Example

Draw the shear and moment diagrams for an overhang beam with a uniform load.

Solution

Load Diagram Resultant of the load is used to find the reactions, but not used again.

Shear Diagram Up 21.3 k, down 4 k/ft for 12' (to -26.7k) then up 42.7 k (to +16 k), slope down to zero.

$$a = \frac{21.3 \text{ k (max shear)}}{4 \frac{\text{k}}{\text{ft}} (\text{load})} = 5.3 \text{ ft}$$

Moment Diagram Both +56.4 k-ft and -32.6 k-ft are maximums. Both curves are downward curved parabolas, one

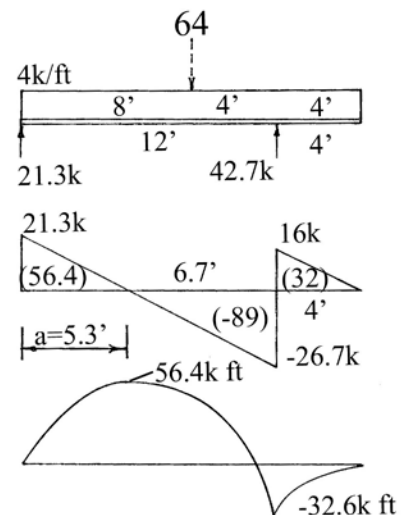



What Every Engineer Should Know About Structures - Part D - Bending Strength of Materials
 A SunCam online continuing education course

with apex at 5.3', the other with apex at right end. Notice the rounding error at the right end of the moment diagram. That is OK because of the assumptions made in the beginning - i.e., point loads, no friction, perfectly straight beams, approximate loads, etc.

Example

Draw the shear and moment diagrams for a beam with a combination of loads.

Solution

Load Diagram Distributed load is converted to a resultant to find the reactions, but the resultant is not used afterward.

Shear Diagram Start at left end, then up straight 15.5 k, then horizontal 4', then down 10 k (to 5.5), then horizontal 4', then slope down at a rate of 4 k/ft (to -26.5), then up 26.5 k to zero.

$$a = \frac{5.5 \text{ k (max shear)}}{4 \frac{\text{k}}{\text{ft}} \text{ (load)}} = 1.4 \text{ ft}$$

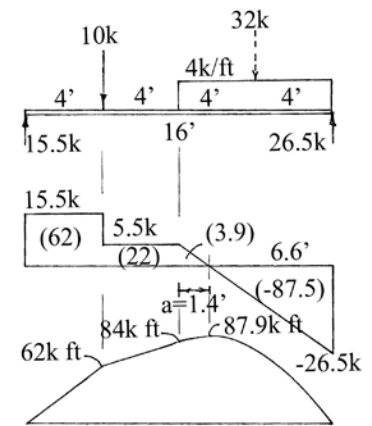

Moment Diagram Maximum of 87.9 k-ft is at 9.4' from left end.

Show 62 k-ft and 84 k-ft breakpoint values. Parabola and straight line are tangent at 8' from the left end.

Notice the rounding error of 0.4 k-ft in the moment diagram.

Example

Draw the shear and moment diagrams for a simple beam with a triangular load.

Solution

Load Diagram Resultant acts at 2/3 of length (don't forget area has a 1/2 factor)

Shear Diagram Start at left end, then up straight 21.3 k, then parabola down to -42.7 k (apex at left end).

"a" is computed from free-body diagram below:

The dimension "x" in the free-body diagram is distance "a" on the shear diagram (where shear equals zero).

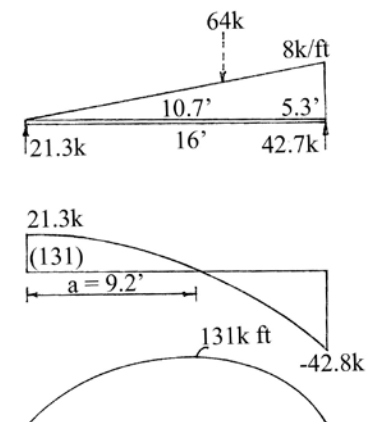



What Every Engineer Should Know About Structures - Part D - Bending Strength of Materials
 A SunCam online continuing education course

$$\Sigma F_y = 0 \Rightarrow 21.3 \uparrow = \frac{x^2}{4} \downarrow \Rightarrow x^2 = 85.2$$

$$x = \sqrt{85.2} \Rightarrow x = 9.2'$$

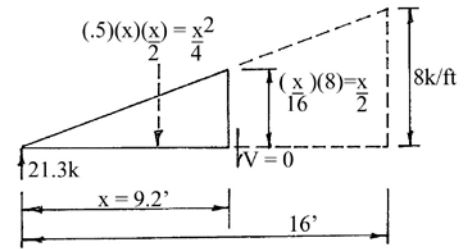

The area under the shear diagram from left end to 9.2' (parabola) is $(\frac{2}{3})bh = (\frac{2}{3})(9.2')(21.3k) = 131k \cdot ft$

Moment Diagram Curve is a cubic with maximum at 9.2' from left end.

Another Thing About Shear and Moment Diagrams

Rule 1 states that the diagram below is derived from the one above. And Rule 4 states that the slope of a line at any point equals the value of the diagram above at that point. A couple of examples:

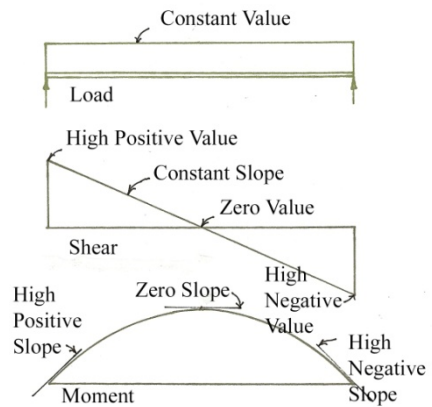

Example

The value of the load is constant, therefore the slope of the shear is constant. Also notice that as the value of the shear goes from a high positive value at the left end, through zero, to a high negative value at the right end, the slope of the moment diagram also goes from a high positive value, to zero, to a high negative value.

Example

Again, the value of the load is constant, therefore the value of the slope of the shear is constant. Similarly, the slope of the moment diagram changes as the value of the shear diagram changes. The noticeable difference in this diagram is the discontinuity of the moment diagram at the right reaction. As the shear diagram passes through zero at the right support, the slope to the left and right of the moment diagram still follow the "value to slope" rule.

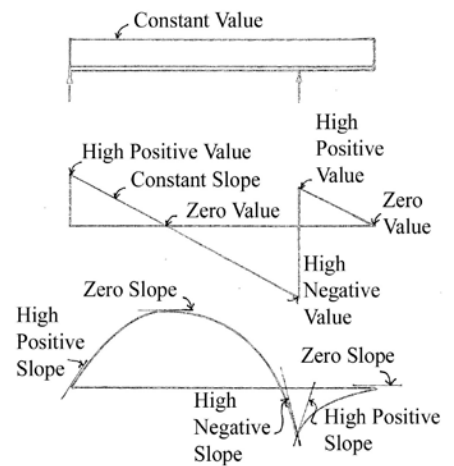

Now that we know how to determine the maximum bending moment in a beam, both positive and negative, and where it occurs, we can determine the maximum bending stress in a beam. What follows is a nifty way to show and explain the principles of bending stresses in beams. Follow along - this will be fun and enlightening. ☺



What Every Engineer Should Know About Structures - Part D - Bending Strength of Materials
A SunCam online continuing education course

Bending Stress

Bending stress is the stress created in a beam to resist the applied external bending moments that occur along a beam. When designing a beam (picking a beam size and shape that can carry an anticipated load), the maximum moment in a beam is often the first criteria to be met.

The bending stresses created inside of a beam when the beam is subjected to a bending moment can be easily seen by considering what happens when a straight bar is bent into a circle. For this example, we will use a 2" x 2" x 6,283.2 inch long straight steel bar. Hmm... That's an odd length. This bar is roughly 1 and 2/3 lengths of a football field. It's a really long bar! Anyway, imagine it laying flat on a friction free surface – say inside of a big warehouse with a very smooth floor. As it lays there, we will apply a moment to each end of the bar.

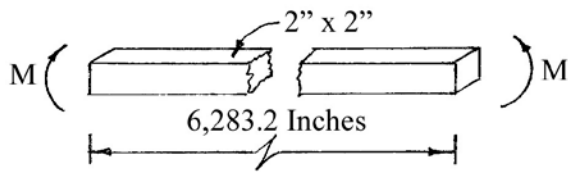

When the moment is applied to each end of the bar, the bar will bend. As the moment gets bigger, the bar will bend further. Eventually, when the moment gets to just the correct amount, the bar will be bent into a circle and the ends will touch. It will form a complete circle. And guess what. The inside diameter of that circle will be exactly 1,998 inches. The outside diameter of that circle will be 2,002 inches. And the centerline of the bar will have a diameter of 2,000 inches.

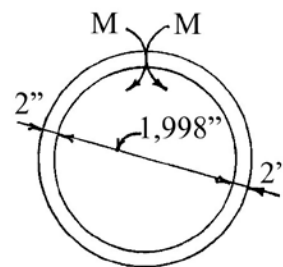

Knowing that the circumference of a circle equals πD , then the centerline length of the bent bar equals πD . \Rightarrow *Length of centerline* = $\pi D = \pi (2,000) = 6,283.2$ inches. (What luck ☺).

When the bar was straight, what is now the inside face and the outside face of the beam were both the same length – and that length was the same as the centerline length is now – 6,283.2 inches. Since the straight bar has been curved into a circle (by applying a bending moment to the straight bar and allowing it to bend to form a circle), the inside face of the bar has become shorter and the outside face of the bar has become longer. And the centerline of the bar has remained the same length. We can do some simple math to determine how much longer and shorter the outside and inside faces have become.

The outside diameter of the bar is 2002 inches. The new outside length of the bar, then, is $\pi (2002) = 6,289.5$ inches.

The inside diameter of the bar is 1998 inches. The new inside length of the bar, then, is $\pi (1998) = 6,276.9$ inches.



What Every Engineer Should Know About Structures - Part D - Bending Strength of Materials
A SunCam online continuing education course

And the differences in lengths are the differences between the original length – 6,283.2 inches – and the new lengths. The inside length has shrunk by 6.3 inches (6,283.2 minus 6,276.9) and the outside length has grown by 6.3 inches (6,289.5 minus 6,283.2).

In structural terms, the inside face of the formerly straight bar has deformed by a minus 6.3 inches (-6.3”) and the outside face of the formerly straight bar has deformed by a plus 6.3 inches (+6.3”). In other words, the total deformation over an original length of 6,283.2 inches is 6.3 inches. To calculate the strain (which is inches per inch), simply divide the change in length by the original length.

For the inside face of the bent bar:

$$\text{Strain} = \epsilon = \frac{\delta L}{L} = \frac{-6.3''}{6,283.2} = -0.0010 \text{ in/in}$$

For the outside face of the bent bar:

$$\text{Strain} = \epsilon = \frac{\delta L}{L} = \frac{+6.3''}{6,283.2} = +0.0010 \text{ in/in}$$

Since the Modulus of Elasticity of steel, E, equals 29,000 ksi, and we know that $E = \frac{\sigma}{\epsilon}$, we can find the stresses caused by the strains in the faces of the steel bar.

For the stress on the inside face of the bent bar

$$\text{Stress} = \sigma = \epsilon E = (-0.0010 \text{ in/in})(29,000 \text{ ksi}) = -29 \text{ ksi}$$

For the stress on the outside face of the bent bar

$$\text{Stress} = \sigma = \epsilon E = (+0.0010 \text{ in/in})(29,000 \text{ ksi}) = 29 \text{ ksi}$$

The inside face of the bar got shorter, therefore the stress on the inside face of the bar is a compressive stress. The outside face of the bar got longer, therefore the stress on the outside face of the bar is a tensile stress.

And, for the centerline of the formerly straight bar, there was no change in length, therefore no strain, and therefore no stress. There is no stress in the bar at the centerline of the bar - along the neutral axis. Also, since the only force acting on the bent bar is a bending moment at each end, the compressive stresses and tensile stresses are constant for the entire length of the beam.

We can now plot this information on a diagram of the cross section of the original bar.

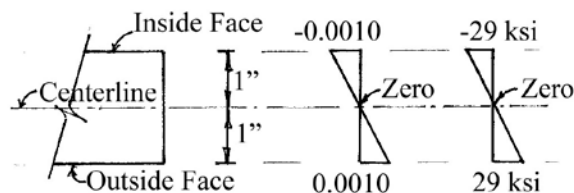



What Every Engineer Should Know About Structures - Part D - Bending Strength of Materials
 A SunCam online continuing education course

We know what the calculated stresses are on the faces of the bar only. This stress will vary across the cross section of the bar (from the inside face to the outside face) from minus 29 ksi on the inside face of the bar to zero at the centerline of the bar to a plus 29 ksi on the outside face of the bar.

The total compressive force on the inside portion of the bar is simply the volume of the stress diagram on the cross section. And the total tensile force on the outside portion of the bar is the volume of the stress diagram on the cross section. The resultant of the compressive force and the resultant of the tensile force act at the centroids of their stress diagrams - at the 1/3 - 2/3 point.

The magnitude of the compressive force is the volume of the stress diagram in compression and is computed as follows: $Force = (1/2) \cdot (2 \text{ inches wide}) \cdot (1 \text{ inch high}) \cdot (29 \text{ ksi}) = 29 \text{ k}$. And, similarly, the magnitude of the tensile force is 29 kips. As shown on the diagram below.

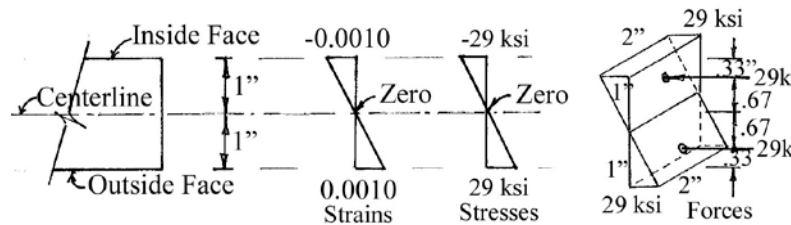

The two 29 kip forces are 1.33 inches (.67 + .67) apart and form a force couple. The force times the distance between them equals the moment on the face of the cross section.

$$M = Fd = (29 \text{ kips})(1.33 \text{ inches}) = 38.6 \text{ kip-in} = 3.22 \text{ kip-ft}$$

A bending moment of 3.22 kip-ft was required to bend the straight bar into a circle. And, again, because the bending moment is the only force acting on the bar, the bending moment is constant along the entire length of the beam. A bending moment of 3.22 kip-ft exists at all points around the circle.

General Bending Stress Formula

The stress, strain, and force relationships derived in the example above are typical for all bending problems. To derive a **general bending stress formula**, the stress, strain, and force relationships are used – plus two other conditions must be met.

The two other conditions the general stress formula must meet are, first, the formula must account for the variation in stress from zero at the neutral axis to a maximum at the outer face; and, second, the formula must give greater value to the area of a cross section that is the farthest



What Every Engineer Should Know About Structures - Part D - Bending Strength of Materials
A SunCam online continuing education course

from the neutral axis. The property of a cross sectional area that gives greater value to the area furthest removed from the neutral axis is the moment of inertia, I.

The **general bending stress formula** listed below has these characteristics

$$\sigma = \frac{my}{I}$$

Where

σ = bending stress (psi, ksi, or MPa)

m = bending moment (lb-in, k-in, or N-m)

y = distance from the neutral axis (in or mm)

I = moment of inertia (in⁴ or mm⁴ x 10⁶)

The general bending stress formula can be used to calculate the bending stress at any point in the cross section of a beam. And the value of the bending stress will vary anywhere from a maximum at the faces to zero at the center of the cross section. Actually it's not the "center" of the cross section all the time. More accurately, it is at the centroid of the cross section. Or center of gravity of the cross section. Or, if along the entire beam, this point of zero stress is called the **neutral axis** of the beam.

Maximum Bending Stress Formula

Sometimes it is necessary to calculate the stress in a beam cross section at some point other than where the stress is maximum. And, when that is the case, the above formula is used. However, in most instances only the maximum bending stress is needed. The maximum bending stress in a structural member occurs in the outer fibers of the beam – the **extreme fibers**. This is at a point where the “y” dimension in the general bending stress formula is a maximum. The maximum dimension for “y” is given a special symbol, “c”. Thus, c = y (max) = half the depth of a symmetrical beam cross section.

So, the general bending stress formula becomes the **maximum bending stress formula** by substituting “c” for “y” in the formula.

$$\sigma = \frac{my}{I} = \frac{mc}{I}$$

Let's not forget that we are only talking about straight beams (not curved or bent in any amount) and having a uniform cross section for the entire length. This will cover most of the "normal" beam design problems.

Section Modulus

Given these conditions, "I" is a calculated property of the cross section based in part on the depth of the beam, h. Also, "c" is a calculated property based on the depth of the beam, h. And "h" doesn't change from one calculation to the other. Therefore, "I" and "c" can be combined as $\frac{I}{c}$



What Every Engineer Should Know About Structures - Part D - Bending Strength of Materials
A SunCam online continuing education course

and can be listed in table of properties as "S", the **Section Modulus**. Because this formula for bending stresses is used so often, the values for S for each beam is also listed in the reference manuals.

Going back to the maximum bending stress formula, the **maximum bending stress formula** becomes

$$\sigma = \frac{mc}{I} = \frac{m}{I/c} = \frac{m}{S}$$

Where $S = \frac{I}{c}$

Where the moment of inertia, I, is a measure of the stiffness of a beam, the section modulus, S, is a measure of the strength of a beam. A large section modulus represents a strong beam able to carry a large load. However, if the moment of inertia of the beam is small, it may deflect excessively.

The section modulus, S, for some beam shapes can be calculated directly without calculating the moment of inertia. For example, the section modulus for a rectangle is equal to $\frac{bh^2}{6}$, as follows:

$$I = \frac{bh^3}{12}, \text{ and } c \text{ equals half the depth equals } h/2. \text{ Then } S = \frac{I}{c} = \frac{bh^3/12}{h/2} = \frac{bh^2}{6}$$

The **maximum bending stress formula** becomes:

$$\sigma_{max} = \frac{m}{S}$$

Where

σ = maximum bending stress (psi, ksi, or MPa)

c = distance from neutral axis to face of beam (in or mm)

S = section modulus of the cross section (in^3 or $\text{mm}^3 \times 10^3$)

There it is - the way to calculate bending stresses in a beam when the bending moment is known. In my entire career, probably half of my structural calculations involved this formula. It is that important.

Example

What is the maximum bending stress in the circular ring problem if the bending moment required to bend the bar into a ring equals 38.6 kip-in? The bar cross section is 2" x 2". Use the maximum bending stress formula.

Solution

$$S = \frac{bh^2}{6} = \frac{2 \times 2^2}{6} = 1.33 \text{ in}^3$$



What Every Engineer Should Know About Structures - Part D - Bending Strength of Materials
A SunCam online continuing education course

$$\sigma = \frac{m}{S} = \frac{38.6 \text{ kip-in}}{1.33 \text{ in}^3} = 29.0 \text{ ksi check } \checkmark$$

Example

What is the bending stress at a point 0.5 inches above the neutral axis in the circular ring problem if the bending moment required to bend the bar into a ring equals 38.6 kip-in? The bar cross section is 2" x 2". Use the general bending stress formula.

Solution

$$I = \frac{bh^3}{12} = \frac{2 \times 2^3}{12} = 1.33 \text{ in}^4$$

$$\sigma = \frac{my}{I} = \frac{(38.6 \text{ kip-in})(0.5 \text{ in})}{1.33 \text{ in}^4} = 14.5 \text{ ksi}$$

Let's move on to shear stresses in a beam. Think back to the previous course in this series What Every Engineer Should Know about Structures - Part C - Axial Strength of Materials. When we looked at horizontal shear in a bolt, we found that a horizontal shear force on a bolt produces a vertical shear force along the long axis of the bolt. Then we decided that except for very short, large diameter bolts, it should be ignored.

In beams the exact same sort of thing happens. Except in beams, it is a vertical shear force that will produce a horizontal shear force within the beam. And, in beams, these horizontal shear forces should not be ignored. They should always be checked because sometimes they are large enough to govern the selection of a beam. Usually bending stresses govern, but, sometimes, the shear stresses govern.

Shear Stresses in Beams

The shear stresses in a beam can be seen by taking a look at the forces and stresses in a beam. Let's consider a rectangular 3 inch by 10 inch beam that is 12 feet long. It is simply supported and carries a single, 6 kip load at the two-thirds point along the beam.

The load diagram, the shear diagram, and the moment diagram are shown at the right. Pick two points along the beam, one at 4 feet from the left end and the other at 6 feet from the left end, and calculate the bending stresses in the beam at those two points.

The bending moment at 4 feet is 8 kip-ft, and the bending moment at 6 feet is 12 kip-ft. The maximum bending stresses in the beam at those two points are found by using the maximum bending stress formula, $\sigma = \frac{M}{S}$, where $S = \frac{bh^2}{6} = \frac{3(10)^2}{6} = 50 \text{ in}^3$

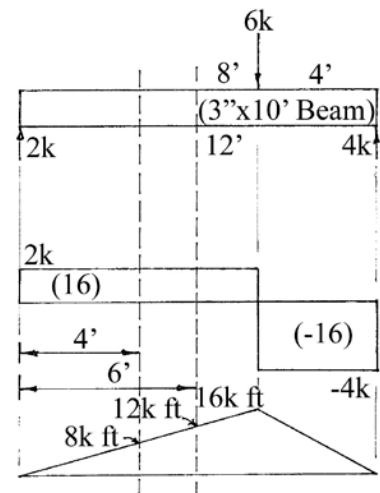



What Every Engineer Should Know About Structures - Part D - Bending Strength of Materials
 A SunCam online continuing education course

$$\sigma(\text{at } 4') = \frac{M}{S} = \frac{\left(12 \frac{\text{in}}{\text{ft}}\right) (8 \text{ kip} - \text{ft})}{50 \text{ in}^3} = 1.92 \text{ ksi}$$

$$\sigma(\text{at } 6') = \frac{M}{S} = \frac{\left(12 \frac{\text{in}}{\text{ft}}\right) (12 \text{ kip} - \text{ft})}{50 \text{ in}^3} = 2.88 \text{ ksi}$$

The bending stresses in the beam can be plotted as before.

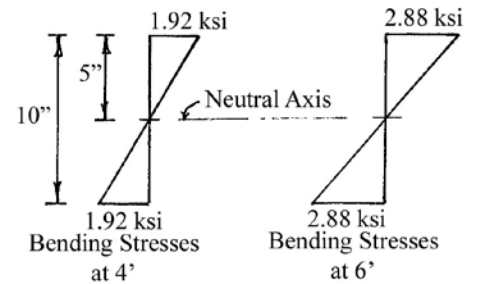

Next, we are going to isolate two pieces of the beam and take a look at the forces and stresses on each piece. The first piece of beam we are going to isolate is the piece between 4 and 6 feet from the left end and above the neutral axis of the beam (above the centerline).

The second piece we're going to isolate is again between the 4 foot and 6 foot marks, but this time from the top of the beam down to only 3 inches. The two free bodies are shown below.

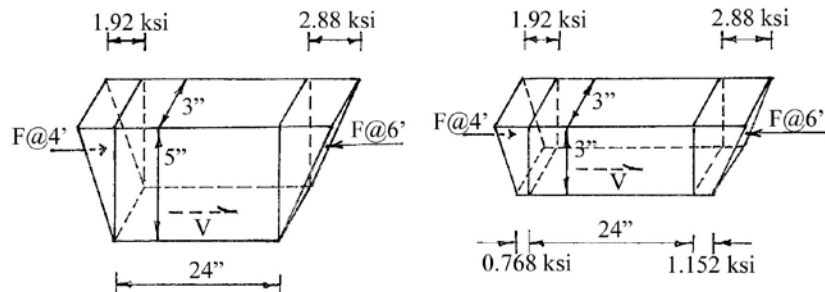

The compressive stresses on each end of each piece of beam are converted to forces. Notice that these compressive forces are not equal. Because the piece of beam must be in equilibrium, there must be another force acting on the piece. And there is! That force is an internal shear force, V , acting on the horizontal plane at 5 inches and 3 inches below the top of the beam.

The horizontal shear force, V , is converted to a shear stress, τ , simply by dividing the force by the area over which it acts. In this case, the area over which it acts is the length of the piece of beam times the width, which is 24 inches by 3 inches. The calculations are shown below.



What Every Engineer Should Know About Structures - Part D - Bending Strength of Materials
A SunCam online continuing education course

Shear Stress at Neutral Axis	Shear Stress at 3" Down From Top
$F_{@ 4'} = \left(\frac{1}{2}\right) (3'')(5'')(1.92 \text{ ksi}) = 14.4 \text{ kips}$	$F_{@ 4'} = (3'')(3'') \left(\frac{(1.92 + 0.768)}{2}\right) = 12.1 \text{ kips}$
$F_{@ 6'} = \left(\frac{1}{2}\right) (3'')(5'')(2.88 \text{ ksi}) = 21.6 \text{ kips}$	$F_{@ 6'} = (3'')(3'') \left(\frac{(2.88 + 1.152)}{2}\right) = 18.14 \text{ kips}$
$V = F_{@ 6'} - F_{@ 4'} = 21.6 - 14.4 = 7.2 \text{ kips}$	$V = F_{@ 6'} - F_{@ 4'} = 18.14 - 12.1 = 6.04 \text{ kips}$
$\tau = \frac{V}{A} = \frac{7.2 \text{ kips}}{(3'')(24'')} = 0.100 \text{ ksi}$	$\tau = \frac{V}{A} = \frac{6.04 \text{ kips}}{(3'')(24'')} = 0.084 \text{ ksi}$

Notice that the horizontal shear stress in the beam is larger at the center - along the neutral axis of the beam - than it is nearer the top of the beam. In just a bit, we'll plot the value of the shear stress and show that it varies through the beam from top to bottom. We'll see that the horizontal shear stress is zero at the top and bottom of the beam and it is maximum at the neutral axis of the beam.

The calculations above consider the horizontal shear stress along a surface that is 24 inches long. The calculated shear stress is an average over the 24 inch length. As the length gets shorter and shorter, the shear stress approaches the value at a point. This concept leads to the thought that the derivation of a general shear stress formula would use calculus. And that thought would be correct. Calculus is used to derive the general shear stress formula. We will not derive the formula. We will simply state it and use it.

General Shear Stress Formula

The **general shear stress formula** for computing the shear stress, τ , at any point in a beam is

$$\tau = \frac{VQ}{Ib}$$

Where

- V = vertical shear force at the point - usually taken directly from the shear diagram (lb, kip)
- Q = first moment of area about the neutral axis of the area away from the shear plane (in³)
- I = moment of inertia of the entire cross section (in⁴)
- b = width of the beam at the point where the shear stress is to be calculated (in)
 - note: some books use "t" as the width rather than "b"



What Every Engineer Should Know About Structures - Part D - Bending Strength of Materials
 A SunCam online continuing education course

In the general shear stress formula, there is only one variable that we have not yet studied - "Q", the first moment of area of the cross section that is away from the shear plane in question. It is a value that must be calculated to solve for the shear stress at any point in a beam. A couple of examples will make it clear.

The rectangular cross section shown calculates the first moment of area as $= A \cdot y$. In this shaped cross section, there is only one area above (or away) from the point where the horizontal shear stress is wanted. Thus, the value of Q at 4 inches down from the top of the beam is calculated as:

$$Q = A \cdot y = (4" \times 4")(3") = 48 \text{ in}^3$$

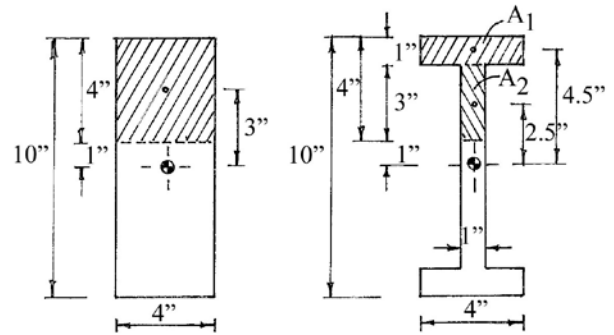

In a cross section such as the "I" shown above, the first moment of area is simply the sum of the individual cross sectional areas. The value of Q at 4 inches down from the top is calculated as:

$$Q = A_1 \cdot y_1 + A_2 \cdot y_2 = [(1" \times 4")(4.5")] + [(3" \times 1")(2.5")] = 18 + 7.5 = 25.5 \text{ in}^3$$

The value Q varies along the depth of the beam. It is zero at the top of the beam simply because the area above or away from the point in question is zero. There is no area beyond the top of the beam. And $Q = \text{zero}$ at the bottom of the beam because the area is the entire cross section, and the distance from the centroid of the entire beam cross section to the centroid of the area in question is zero.

To demonstrate how the horizontal shear stress varies across the depth of a beam cross section, let's calculate the horizontal shear stress at several points of a rectangular shaped beam and plot them.

Let's say we pick a point along the length of a 4 inch wide by 10 inch deep beam where the vertical shear force is 2,000 pounds (this value was obtained from a shear diagram).

$$\tau = \frac{VQ}{Ib}$$

Where:

$$V = 2,000 \text{ lb}$$

$$I = \frac{bh^3}{12} = \frac{(4")(10")^3}{12} = 333 \text{ in}^4$$

$$b = 4 \text{ in}$$



What Every Engineer Should Know About Structures - Part D - Bending Strength of Materials
A SunCam online continuing education course

The drawings below show the areas for Q at several distances down from the top of the beam. When calculating the horizontal shear stress, it is a good idea to sketch the cross section and shade the area above the shear plane. This helps keep the calculations clear in your mind.

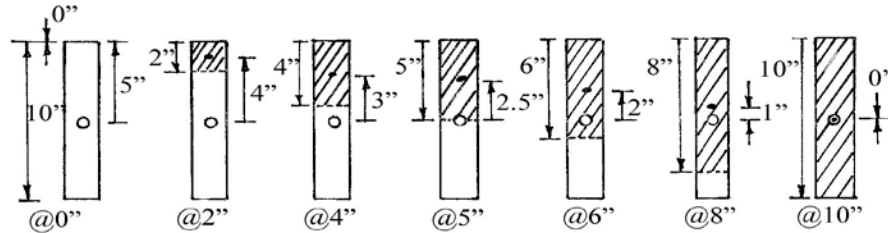

x	V	I	b	A_x	y	$Q=Ay$	$\tau = \frac{VQ}{Ib}$
(in)	(lbs)	(in ⁴)	(in)	(in ²)	(in)	(in ³)	(psi)
@ 0"	2,000	333	4	0	5	0	0
@ 2"	2,000	333	4	8	4	32	48
@ 4"	2,000	333	4	16	3	48	72
@ 5"	2,000	333	4	20	2.5	50	75
@ 6"	2,000	333	4	24	2	48	72
@ 8"	2,000	333	4	32	1	32	48
@ 10"	2,000	333	4	40	0	0	0

From the values in the table, plot the horizontal shear stresses for the rectangular beam. The shear stresses are symmetrical about the neutral axis for a symmetrical beam - such as the 4" by 10" example above. Other beam cross sections that are symmetrical also have the same symmetry about the neutral axis. That is, the horizontal shear stress is zero at the top and bottom of the beam and a maximum at the neutral axis.

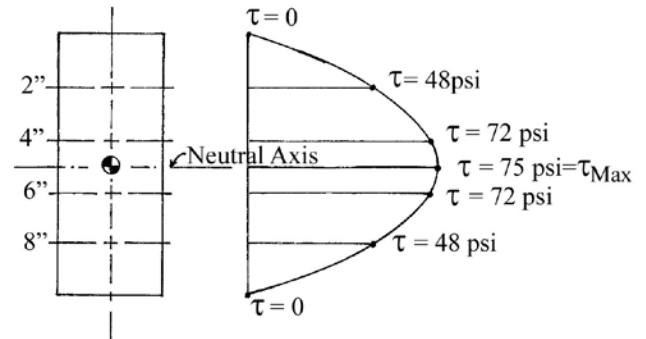

We'll now plot the shear stresses for an "I" section beam. The drawing below only shows the cut sections for half of the beam. The cuts are similar in the bottom half of the cross section.

Plot the values of the horizontal shear stress for a 10 inch deep I-section beam. The flanges are 4 inches wide by 1 inch thick. And the web is 1 inch wide. Again, use a vertical shear force at that section of the beam equal to 2,000 lbs (2 kip). The moment of inertia of the cross section is 205 in⁴.



What Every Engineer Should Know About Structures - Part D - Bending Strength of Materials
 A SunCam online continuing education course

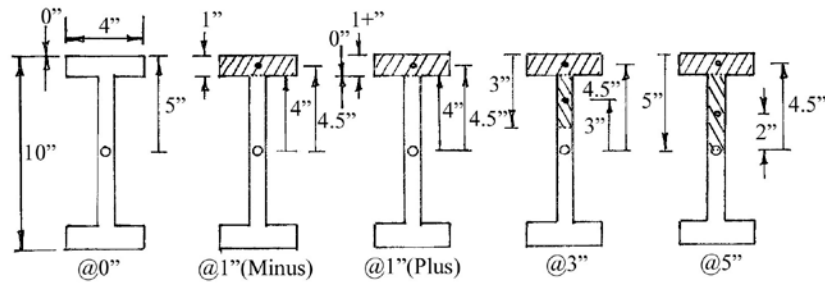

The calculations will be set up to consider each part of the cross section separately. The value for Q will be calculated for each piece (top flange, web, and bottom flange) and then tallied at the end. Only then will we evaluate the horizontal shear stress formula, $= \frac{VQ}{Ib}$. Also in the calculations, we will evaluate the horizontal shear stress twice at about 1 inch down from the top, and again about 9" down from the top. We label the two points near the top as 1"- and 1"+. The 1"(minus) is in the flange just above its intersection with the web. The 1"(plus) is in the web just below the flange to web intersection. What this does is causes the stress to "jump" as it goes from the 4" wide flange to the 1" wide web. The same concept is true for the web to flange intersection at the bottom. The plot of the stresses shows the dramatic increase in stress in the web versus the stress in the flange. This is an important point which we will address in a minute.

When we do the calculations in table form, we will calculate the Q for each part of the cross section, total them up for each point, and then calculate the horizontal shear stress for that point.

	V	I	b	A ₁	y ₁	Q ₁	A ₂	y ₂	Q ₂	A ₃	y ₃	Q ₃	ΣQ	$\frac{VQ}{Ib}$
	kip	in ⁴	in	in ²	in	in ³	in ²	in	in ³	in ²	in	in ³	in ³	psi
0"	2	205	4	0	5	0							0	0
1"-	2	205	4	4	4.5	18							18	43.9
1"+	2	205	1	4	4.5	18	0	4	0				18	176
3"	2	205	1	4	4.5	18	2	3	6				24	234
5"	2	205	1	4	4.5	18	4	2	8				26	254
7"	2	205	1	4	4.5	18	6	1	6				24	234
9"-	2	205	1	4	4.5	18	8	0	0				18	176
9"+	2	205	4	4	4.5	18	8	0	0	0	-4	0	18	43.9
10"	2	205	4	4	4.5	18	8	0	0	4	-4.5	-18	0	0

Notice that the y₃ distances are negative 4" and 4.5". This is because they are the only areas used in the calculation for Q where the distance from the center of gravity of the entire cross section to the smaller area is below the neutral axis.



What Every Engineer Should Know About Structures - Part D - Bending Strength of Materials
A SunCam online continuing education course

Plot of horizontal shear stresses in an I-beam cross section.

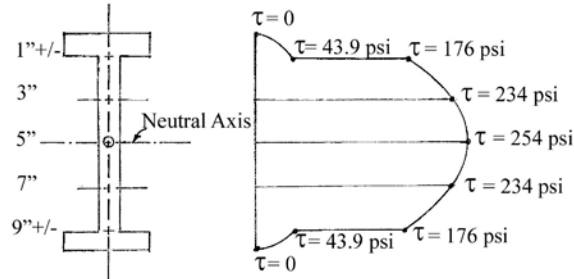

Shear Stress Formula for a Rectangular Wood Beam

Usually when designing or analyzing a wood beam, it is the maximum horizontal shear stress that interests us. And wooden beams usually have rectangular cross sections. That means that the term $\frac{Q}{Ib}$ of the general shear formula can be simplified for the case of the maximum value for Q. The maximum value for Q occurs at the neutral axis. The area for that Q is the area above the neutral axis. Then:

$$Q = A \cdot y = (\text{width} \times \text{height})(y) = \left(b \times \frac{h}{2}\right)\left(\frac{h}{4}\right) = \frac{bh^2}{8}$$

And:

$$I = \frac{bh^3}{12}$$

Therefore:

$$\frac{Q}{Ib} = \frac{\frac{bh^2}{8}}{\left(\frac{bh^3}{12}\right)(b)} = \frac{1.5}{bh} = \frac{1.5}{A}$$

Substituting we get the **maximum horizontal shear stress formula** for a rectangular wooden beam.

$$\tau_{(max)} = (V)\left(\frac{Q}{Ib}\right) = (V)\left(\frac{1.5}{A}\right)$$

$$\tau_{max} = 1.5 \frac{V}{A}$$

The maximum horizontal shear in a rectangular beam is 1.5 times the average shear at that point. And it occurs on the horizontal plane of the neutral axis. Because wood is relatively weak in shear parallel to the grain, horizontal shear stresses often govern the design of rectangular wood beams. And should always be checked.



What Every Engineer Should Know About Structures - Part D - Bending Strength of Materials
A SunCam online continuing education course

Shear Stress Formula for a Steel I-Beam

Let's now get back to that "important point" that we mentioned just a bit ago. By looking at the plot of the shear stresses in a wide flange beam, it is obvious that almost all of the shear stress is in the web portion of the beam. In a steel I-beam, the graph is even more pronounced - i.e., even more of the stress is in the web rather than in the flanges. Because of this characteristic, we can simplify the general shear stress formula by setting the area of the web equal to the term $\left(\frac{Ib}{Q}\right)$.

$$A_{web} = (\text{beam depth} \times \text{web thickness}) \cong \frac{Ib}{Q}$$

Then, the **simplified shear stress formula for a steel I-beam** is:

$$\tau_{max} = \frac{V}{A_{web}}$$

Using the web area equal to $\frac{Ib}{Q}$ overestimates the value of $\frac{Ib}{Q}$ by approximately 12%, or so. This, in turn, underestimates the shear stress by about 12%. The actual maximum horizontal shear stress is actually about 12% larger than this simplified calculation shows.

This difference is compensated for by the allowable stress in shear used for design and analysis of steel beams. For shear stresses computed using the general shear stress formula, steel has an allowable stress of $0.45F_y$. However for horizontal shear stresses calculated using the simplified shear stress formula, the allowable stress is only $0.4F_y$. The AISC recognizes that the simplified shear stress formula is commonly used. It is very easy to use the simplified shear stress formula. Horizontal shear stress seldom governs the design or analysis of steel beams. However, it should not be ignored. It should be checked each time.

As it turns out, beams that are deep, have short spans, and carry heavy loads are the ones that are most likely to be governed by shear. An example would be the bridge beams carrying a railroad train over an interstate highway. Next time you're traveling on an interstate highway, notice the depth of the bridge beams carrying roads over the interstate. Compare them with the depth of the bridge beams carrying railroad tracks over the highway. The railroad bridge beams are much deeper than the highway bridges. And have shorter spans, too.

So, just like bolts, the beam has both horizontal and vertical shear at every point. In the case of bolts, the original force is usually horizontal which in turn produces a vertical shear. While in beams, the shearing force is vertical and produces a horizontal shear.

A Real Problem

Now let's do a real life example. Something similar to what I was once asked to do.



What Every Engineer Should Know About Structures - Part D - Bending Strength of Materials
A SunCam online continuing education course

Example

Let's say you have been asked if an existing 6 inch deep steel I-beam (which is already in place) can be used to safely lower a piece of machinery to the floor below in a large manufacturing facility. The machine weighs something less than 6 kips. What do you tell those who asked? Is the beam safe to use to lower the load? Or not?

Solution

The first step is to determine the properties of the beam. This is done by carefully measuring the depth, flange width, and flange thickness of the beam. Your trusty AISC Manual of Steel Construction will tell you that the beam is probably a W 6x25 with the properties below. Also the total span of the beam is 16 feet - support to support

Next, put some conditions on the solution. First, that you must be present to witness the lowering of the machine (to make sure that your conditions are being followed). Then, when lowering the load, it should be kept as "static" as possible - which means no jerking or impact loading. The lowering will be done smoothly, gently, and slowly. Assume the load will be hung from the center of the span because that will be the worst case scenario for bending stress. For our purposes, neglect the weight of the beam. If the weight of the beam takes it from a "safe" condition to an "unsafe" condition, then the stresses are too close to the allowable to be called safe. Also, use a full 6 kip load.

Then construct the shear and bending moment diagrams. Pick the maximum shear and the maximum bending moment. And calculate the horizontal shear stress and bending stress in the beam. And, finally compare the calculated stresses with the allowable stresses to make the call whether it is safe to lower the load. Or not.

Beam Properties

$$A = 7.34 \text{ in}^2$$

$$\text{beam depth (h)} = 6.38 \text{ in}$$

$$\text{web thickness} = 0.320 \text{ in}$$

$$A_{\text{web}} = (6.38 \text{ in})(0.320 \text{ in}) = 2.0416 \text{ in}^2$$

$$I = 53.4 \text{ in}^4$$

$$S = 16.7 \text{ in}^3$$

$$E = 29 \times 10^6 \text{ psi}$$

$$\text{Allowable bending stress} = 22 \text{ ksi}$$

$$\text{Allowable shear stress} = 14.4 \text{ ksi}$$

Beam Diagrams

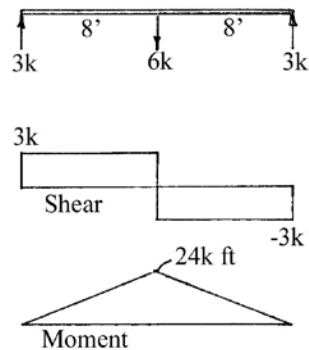



What Every Engineer Should Know About Structures - Part D - Bending Strength of Materials
A SunCam online continuing education course

Calculations -

Bending stress

$$\sigma = \frac{M}{S} = \frac{(24 \text{ k-ft}) \left(\frac{12 \text{ in}}{\text{ft}} \right)}{16.7 \text{ in}^3} = 17.2 \text{ ksi} < 22 \text{ ksi allowable} \Rightarrow \text{OK}$$

Shear stress

$$\tau = \frac{V}{A_{web}} = \frac{3 \text{ kip}}{2.0416 \text{ in}^2} = 1.5 \text{ ksi} \ll 14.4 \text{ ksi allowable} \Rightarrow \text{OK}$$

And, finally, assume that the load is hung from near one support and check again the horizontal shear stress to make sure it is still below the allowable. If the load were hung right at, say, the left support, then nearly the entire load would be carried by the left support (maximum left reaction would be 6 kips). Or the maximum shear force in the beam would be 6 kips at the left end of the beam. Since the maximum shear force in the beam would be 6 kips, which is twice the original shear force of 3 kips, the horizontal shear stress would only be increased to 3 ksi (2 x 1.5 ksi). The shear stress is still way below the allowable.

Therefore, the beam is safe to be used to lower the piece of machinery under the stated conditions.

