



A SunCam online continuing education course

Repair Techniques for Metal Plated Wood Trusses

Part 2: Moderate Truss Repairs

by

Derek L. Rhodes, P.E.



Repair Techniques for Metal Plated Wood Trusses
A SunCam online continuing education course

Table of Contents

Introduction..... 3
Table 3-1 Allowable Shear Capacity of the 10d Gun Nail 5
Table 5-1 Strength Characteristics for OSB Gussets 5
Chapter 6 – Manufacturing Errors 6
Example 6-1 End Vertical Out-of-Plumb 6
Example 6-2 Gap in Top Chord Splices 7
Example 6-3 Bowed Down Top Chord..... 8
Example 6-4 Rotated Plates 9
Example 6-5 Enlarge Floor Truss Chase 10
Chapter 7 – Stubs and Extensions..... 11
Example 7-1 Small Roof Truss Stub..... 12
Example 7-2 Remove Cantilever 13
Example 7-3 Substantial Stub of a Roof Truss 14
Example 7-4 Floor Truss Stub 15
Example 7-5 Small Floor Truss Extension 16
Example 7-6 Roof Truss Extension with a High Heel 17
Example 7-7 Alternate Roof Truss Extension with a High Heel 18
Example 7-8 Roof Truss Extension with a Low Heel..... 19
Example 7-9 Large Extension with Straps..... 20
Chapter 8 – Minor Modifications 23
Example 8-1 Bearing Location Change 24
Example 8-2 Pad up Top Chord a Small Distance..... 25
Example 8-3 Pad up Top Chord a Large Distance..... 26
Example 8-4 Add HVAC Platform 28
Chapter 9 – Major Modifications 29
Example 9-1 Reduce the Height of a Gable Truss 30
Example 9-2 Lower Top Chord Section 31
Example 9-3 Reverse a Web and Add HVAC Platform 34
Example 9-4 Move a Floor Truss Chase..... 35
Example 9-5 Enlarge the Room of an Attic Truss 36
Example 9-6 Cut Out Bottom Chord for Pull-Down Stair..... 39
Example 9-7 Cut Out Bottom Chord for Pull-Down Stair – Alternate Design 42
Conclusion 47
References and Notes..... 47



Repair Techniques for Metal Plated Wood Trusses
A SunCam online continuing education course

Introduction

Metal plated wood trusses are engineered products that are manufactured in a controlled environment and are now used extensively in the wood frame construction industry. Wood trusses provide the architect or building designer greater flexibility in the design of the structure than conventional framed (stick-built) construction. The design is not as limiting with regard to bearing wall locations which enables longer spans and greater ability to shape complicated roof and ceiling profiles. These pre-manufactured wood trusses facilitate a quicker construction schedule and an overall lower cost.

Wood, a renewable resource, has a great deal of manufacturing flexibility. Wood members are easily formed into standard framing sizes, cut into appropriate lengths with odd angles if necessary, and attached to form the wood structure. However, wood is more susceptible than steel or concrete to damage due to internal defects, handling issues, and long term deterioration. Design or manufacturing errors, shipping damage, miscommunication, and change orders are possible causes for the inadequacy of a wood truss for a specific application and therefore a repair or modification of the pre-manufactured wood truss is required. The purpose of this document is to address various repair techniques that could be used to correct damage to the wood members or metal plates, reinforce trusses that do not meet the required specified design loads, or adjust the truss profile or member location to meet other design requirements.

This course is the second part in a three part series which consists of a total of 11 chapters between all three parts. Chapters 1 through 3 provide an introduction to the terms, concepts, and process involved in truss repairs. Chapters 4 through 11 contain actual truss repairs to provide instruction through the use of example. These chapters are broken down as follows

- **Part 1: Introduction and Simple Repair Concepts – Five Chapters.**
 - Chapter 1 – Definitions
 - Chapter 2 – Repair Design Concepts
 - Chapter 3 – Wood Truss Repair Connections
 - Chapter 4 – Member Damage and Defects
 - Chapter 5 – Plate Damage
- **Part 2: Moderate Truss Repairs - Four Chapters – Current Part**
 - Chapter 6 – Manufacturing Errors
 - Chapter 7 – Stubs and Extensions
 - Chapter 8 – Minor Modifications
 - Chapter 9 – Major Modifications
- **Part 3: Complex Truss Repairs - Two Chapters**
 - Chapter 10 – Volume Ceiling Changes
 - Chapter 11 – Girders and Truss Loading.



Repair Techniques for Metal Plated Wood Trusses
A SunCam online continuing education course

The dimensions used in this document may be in feet (x'), inches (x''), or feet-inches-sixteenths (f-i-s). The repair examples will usually use feet for larger dimensions such as scab members and inches for the smaller dimensions such as Oriented Strand Board (OSB) gussets. Inches are used for all board and plate sizes (2x4, 2x6, etc.). The f-i-s units will be shown in dimension lines that run along the top and bottom of the trusses as shown on the original truss design drawing. As an example of the f-i-s notation, 10-3-8 equals 10'-3 1/2" (3.14 m) because the last one or two digits in that notation is an unreduced fraction so that 8/16" = 1/2" (13 mm). Throughout the document, a metric equivalent is provided in parenthesis for each dimension of the repair examples. The f-i-s dimensions that run along the top and bottom of the truss are not be converted to reduce clutter. Some sample conversions are provided in the chart to the right. When the lumber size is converted to the metric dimensions, it will be the actual board dimensions rather than the rough dimensions. As an example, a 2x4 which has a final cut dimensions of 1 1/2" x 3 1/2" will be shown as 38 x 89 mm instead of the rough cut dimensions of 51 x 102 mm.

meter	f-i-s
1	3-03-06
2	6-06-12
3	9-10-02
4	13-01-08
5	16-04-14
6	19-08-04
7	22-11-09
8	26-02-15
9	29-06-05
10	32-09-11
15	49-02-09
20	65-07-06

When forces are given in this course, tension forces will have a positive value and compressive forces will be negative.

Tables 3-1 and 5-1 from the first part of the course are repeated below as a reference. This course assumes that the reader is familiar with the terminology and concepts presented in the first part of this course series.



Repair Techniques for Metal Plated Wood Trusses
 A SunCam online continuing education course

Type	Main Member Lumber Type	Side Member Lumber Type	Specific Gravity main - G _m	Specific Gravity side - G _s	Single or Double shear	DOL (Duration of Load)	Diameter D - in.	English Units			Metric Units			
								Length in main - L _m - in.	Length in side - L _s - in.	Connection Capacity (Z) - lbs	Diameter D - mm	Length in main - L _m - mm	Length in side - L _s - mm	Connection Capacity (Z) - N
Roof	SYP	SYP	0.55	0.55	Single	1.15	0.131	1.50	1.50	122	3.33	38.1	38.1	542
Roof	SYP	SPF	0.55	0.42	Single	1.15	0.131	1.50	1.50	106	3.33	38.1	38.1	471
Roof	SPF	SPF	0.42	0.42	Single	1.15	0.131	1.50	1.50	95	3.33	38.1	38.1	423
Roof	SYP	7/16" OSB	0.55	0.50	Single	1.15	0.131	1.50	0.44	87	3.33	38.1	11.1	385
Roof	SYP	7/16" OSB	0.55	0.50	Double	1.15	0.131	1.50	0.44	173	3.33	38.1	11.1	771
Roof	SYP	3/4" OSB	0.55	0.50	Single	1.15	0.131	1.50	0.72	105	3.33	38.1	18.3	465
Floor	SYP	SYP	0.55	0.55	Single	1.00	0.131	1.50	1.50	106	3.33	38.1	38.1	471
Floor	SYP	SPF	0.55	0.42	Single	1.00	0.131	1.50	1.50	92	3.33	38.1	38.1	410
Floor	SYP	7/16" OSB	0.55	0.50	Single	1.00	0.131	2.56	0.44	75	3.33	65.1	11.1	335
Floor	SYP	3/4" OSB	0.55	0.50	Single	1.00	0.131	2.28	0.72	91	3.33	57.9	18.3	404

Table 3-1 Allowable Shear Capacity for the 10d Gun Nail.

Span Rating	Thickness	Allowable Stress
Panel Tension F_{tA} with units of lbs/ft of panel width (kN/m of panel width)		
24/16	7/16" (11 mm)	1,300 (19.0)
48/24	23/32" (18 mm)	2,550 (27.3)
Panel Compression F_{cA} with units of lbs/ft of panel width (kN/m of panel width)		
24/16	7/16" (11 mm)	2,500 (36.5)
48/24	23/32" (18 mm)	4,300 (62.8)
Panel Shear Through-The-Thickness F_{vtv} with units of lbs/ft of shear-resisting panel length (kN/m of shear-resisting panel length)*		
24/16	7/16" (11 mm)	1,980 (28.9)
48/16	23/32" (18 mm)	2,640 (38.5)

*The original table in the Manual for Engineered Wood Construction used units of lbs/in for the Panel Shear Through-The-Thickness table. These values were converted to lbs/ft for consistency.

Table 5-1 Strength Characteristics for OSB Gussets.



Repair Techniques for Metal Plated Wood Trusses
A SunCam online continuing education course

Chapter 6 – Manufacturing Errors:

Manufacturing Errors is one of the least common repair categories. Metal-plated wood trusses are fabricated in a controlled environment with computerized saws and sophisticated jiggging technology and any required repairs usually involve the relatively simple member or plate repairs as covered in Part 1 of this series of courses.

Example 6-1 End-Vertical Member Out-of-Plumb

Problem

The short end vertical of the mono truss was fabricated at a non-vertical angle.

Repair Drawing

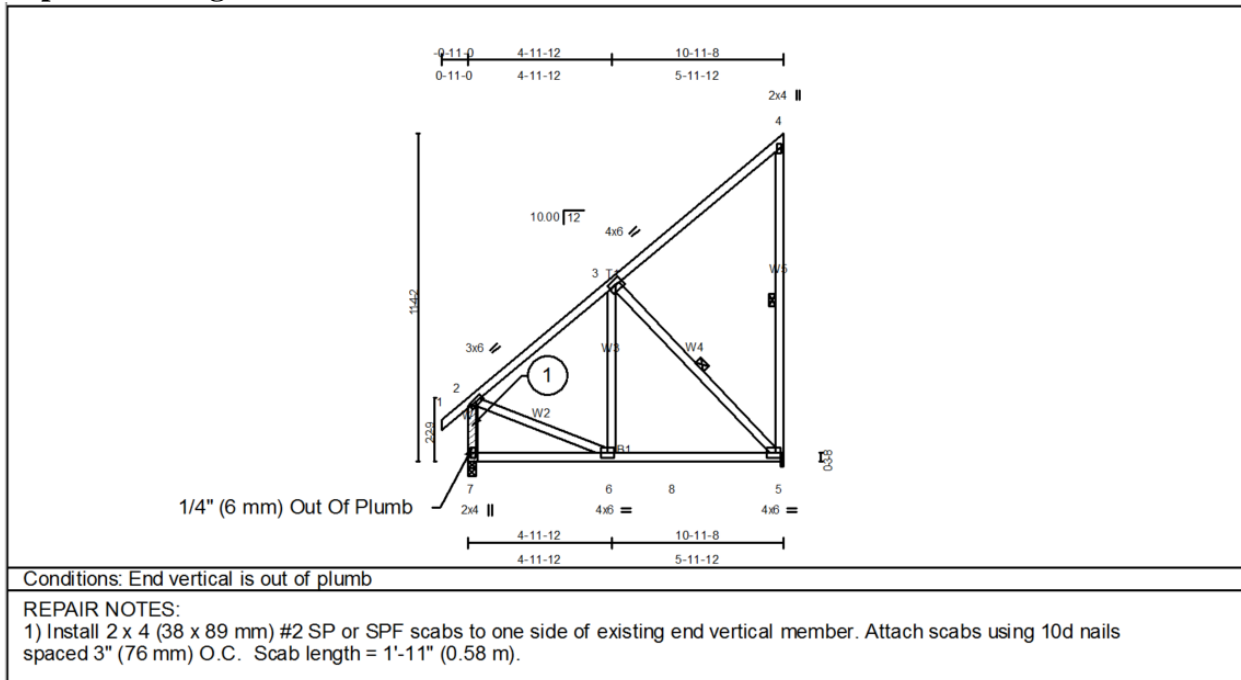

Discussion

The member just needed to line up with similar members in other trusses. Since no plates were compromised, a simple scab was sufficient to prevent any ripples in the exterior finish.



Repair Techniques for Metal Plated Wood Trusses A SunCam online continuing education course

Example 6-2 Gap in Top Chord Splices

Problem

Top chord members were too short causing a gap at the splice joint.

Repair Drawing

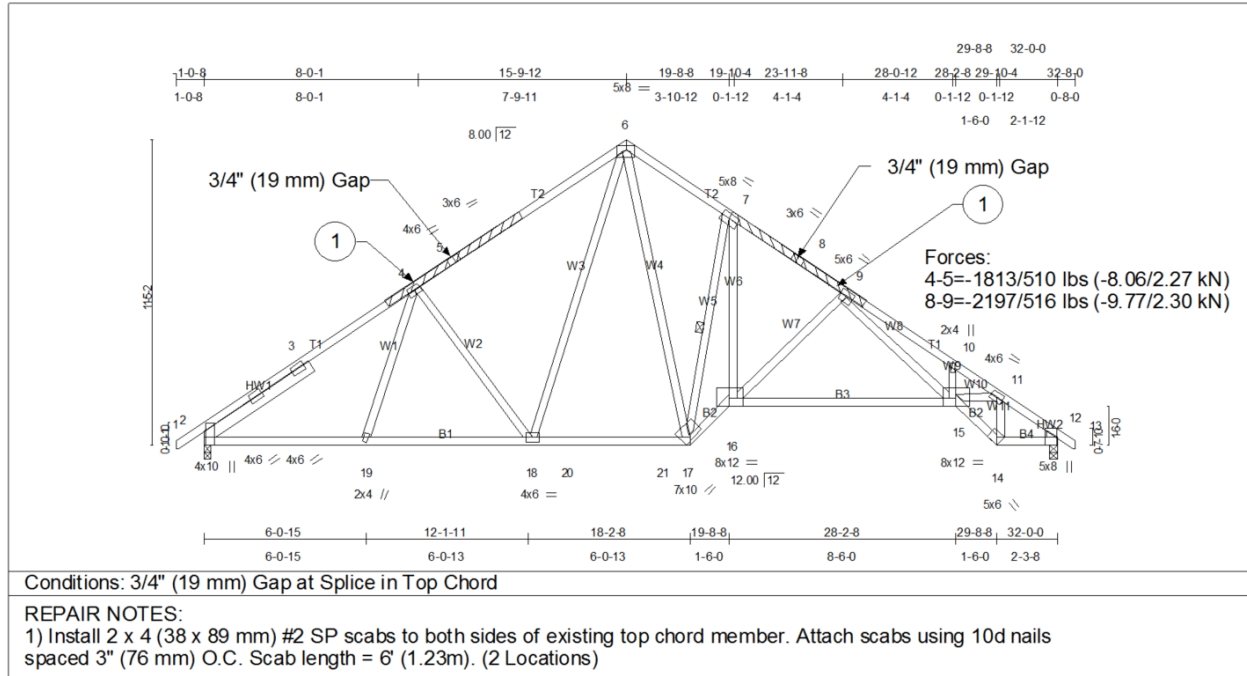

Discussion

According to ANSI/TPI 1-2014 section 3.7.6, the maximum allowable gap between wood members at a joint is between 1/16" (1.6 mm) and 1/8" (3.2 mm), depending on the joint type configuration. The 3/4" (19 mm) gap found at both of the top chord splice joints exceeds this maximum allowable gap. The gaps created a similar situation as if the top chord member was broken or the splice plate had been damaged. The controlling force is the compressive force from joint 8 to joint 9 of -2197 lbs (-9.77 kN). From Table 3-1, the shear capacity of a 10d nail in a roof application with 2x4 (38 x 89 mm) SP scabs is 122 lbs (0.54 kN) requiring a minimum development length of 5' (1.52 m) for a scab applied to one side if the nails are placed 3" (76 mm) o.c. The solution that was selected used 6' (1.82 m) scabs on both sides of the truss because the repair designer prefers two sided repairs whenever possible to eliminate eccentricity.



Repair Techniques for Metal Plated Wood Trusses
A SunCam online continuing education course

Example 6-3 Bowed Down Top Chord

Problem

The top chord of the truss has a dip caused by a web that was either too short or not installed properly.

Repair Drawing

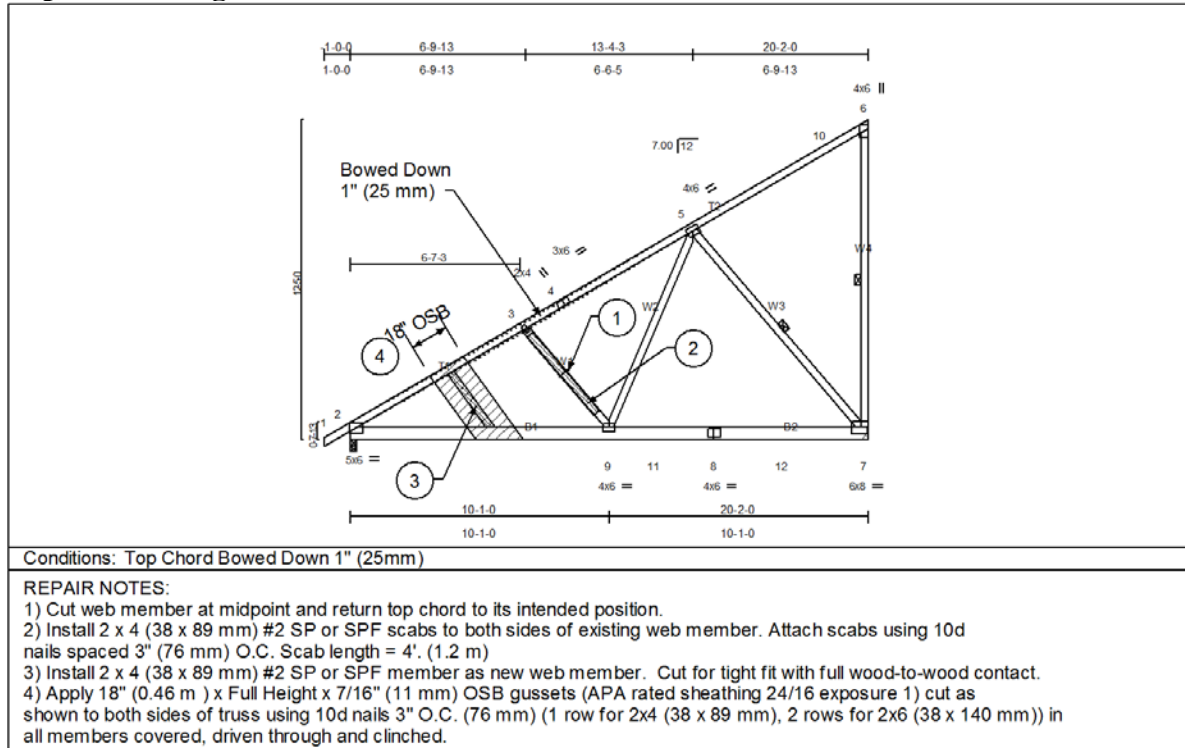

Discussion

When a bow is present in a truss chord member, it is usually between two joints and is often caused by a lumber defect, but in this case the maximum bow was at the joint. In the fabrication process, lumber is usually cut accurately and a jig connection is established at or near each joint so that each joint location is usually within a 1/4" (6 mm) tolerance making this type of error rare. A common repair approach is to scab a member along the existing top chord to get the desired roof plane alleviating the need to cut truss, and that would have been an appropriate repair if the roof sheathing had not already been installed. However, the roof sheathing and the shingles were already in place. The connection between the roof sheathing and the top chord of the truss would require being severed in order to reestablish the desired roof plane. Then, the shingles would have to be removed in order to reconnect the sheathing to the top chord according to the requirements of the building code. The repair as designed allows for the connection between the roof sheathing and the top chord of the truss to remain intact by cutting the key web, moving the top chord to the correct location, and repairing the web with a simple scab repair. The extra web was added to alleviate any bow that may be set in the lumber of the top chord member due to the incorrect location of the joint.



Repair Techniques for Metal Plated Wood Trusses A SunCam online continuing education course

Example 6-4 Rotated Plates

Problem

Two truss plates at top chord joints were rotated beyond acceptable tolerances.

Repair Drawing

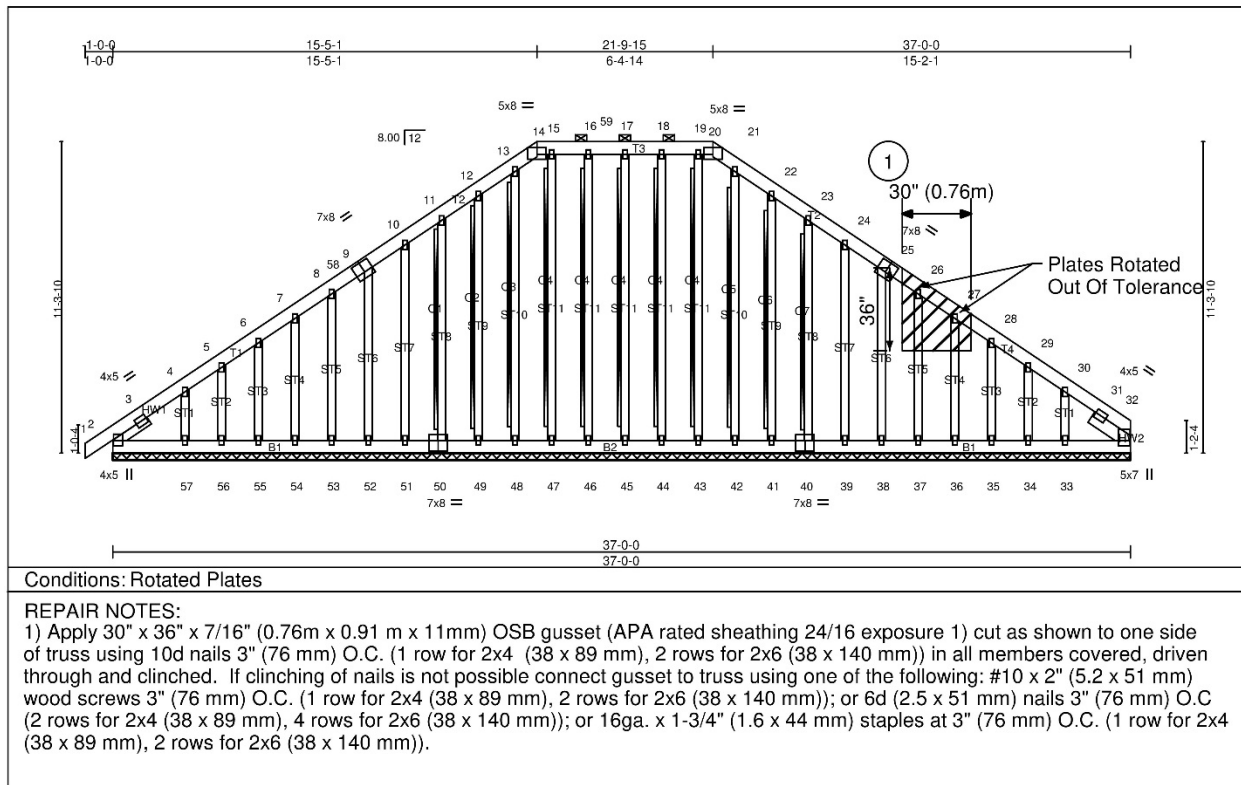

Discussion

Trusses are usually built flat on large tables in modern truss manufacturing facilities making only one face of the truss clearly visible to the truss builders. If there are plate placement issues, the problem usually occurs on the face of the truss that is face down. These issues can be treated just like a damaged plate. Since there were two plates that were rotated in this case, one OSB gusset was sized to cover both joints.

In a gable truss, sheathing is usually already applied to one side, so a one sided repair is necessary. Also, since the truss is continuously supported, the forces in each member are relatively small and so the size of the OSB was chosen based on the geometry of the members and not the forces like other repairs. The standard gun nails can be used if the exterior finish has not yet been installed so that the nails can be clinched, meaning bent over, without damaging the exterior finish. The options for the various shorter connectors were based on the total thickness of the assembly, and were chosen so as to not protrude through to and damage the exterior finish if it has already been installed.



Repair Techniques for Metal Plated Wood Trusses
A SunCam online continuing education course

Example 6-5 Enlarge Floor Truss Chase

Problem

The truss manufacturer used standard cut pieces instead of the custom length pieces per the truss design for the diagonal web members resulting in a small chase.

Repair Drawing

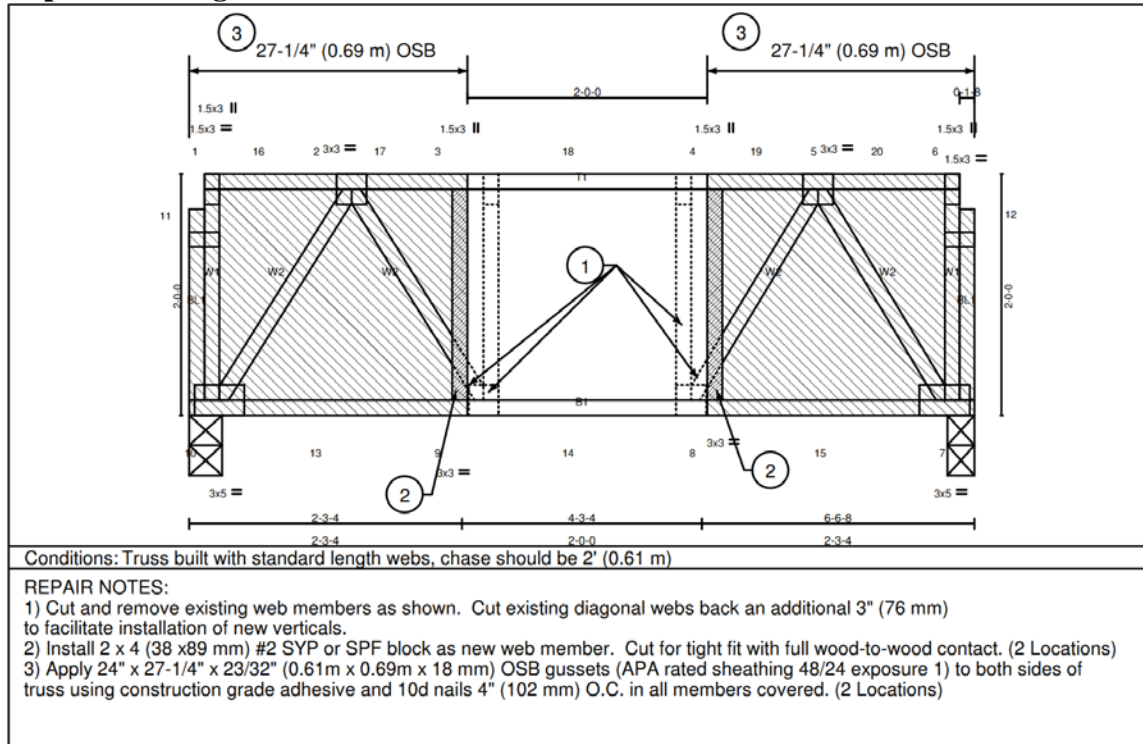

Discussion

Errors in the size or location of a floor truss chase is a common problem and can be caused by design errors, minor variations in lumber thickness of the top and bottom chord members, setting a non-symmetrical truss backwards, changing the size of the ductwork that is to pass through the truss, or manufacturing errors. In this case, the fabricators simply chose diagonal webs that were too long causing the chase to be undersized for the required ductwork. Since the truss was relatively short and the forces were small, the diagonal webs were cut back to allow for the new vertical webs and OSB gussets were sized to provide good perimeter nailing.



Repair Techniques for Metal Plated Wood Trusses
A SunCam online continuing education course

Chapter 7 – Stubs and Extensions

Stub and extension repairs are required when the actual horizontal dimension of the truss is different than the required application. This may be caused by variations in the foundation or supporting framing, changes in the vertical placement of a beam, incorrect plan dimensions, or design errors. If the truss needs to be made shorter, the repair is called a stub, and if the truss needs to be made longer, it is called an extension.

Stubs and Extensions are common repairs in the truss industry. If the dimensional change of the truss is relatively small, the repairs usually involve applying scabs or gussets, but larger changes, where the bearing location has shifted, require adding new members to the support location.



Repair Techniques for Metal Plated Wood Trusses
A SunCam online continuing education course

Example 7-1 Small Roof Truss Stub

Problem

The truss is too long for the application and needs to be shortened a small distance.

Repair Drawing

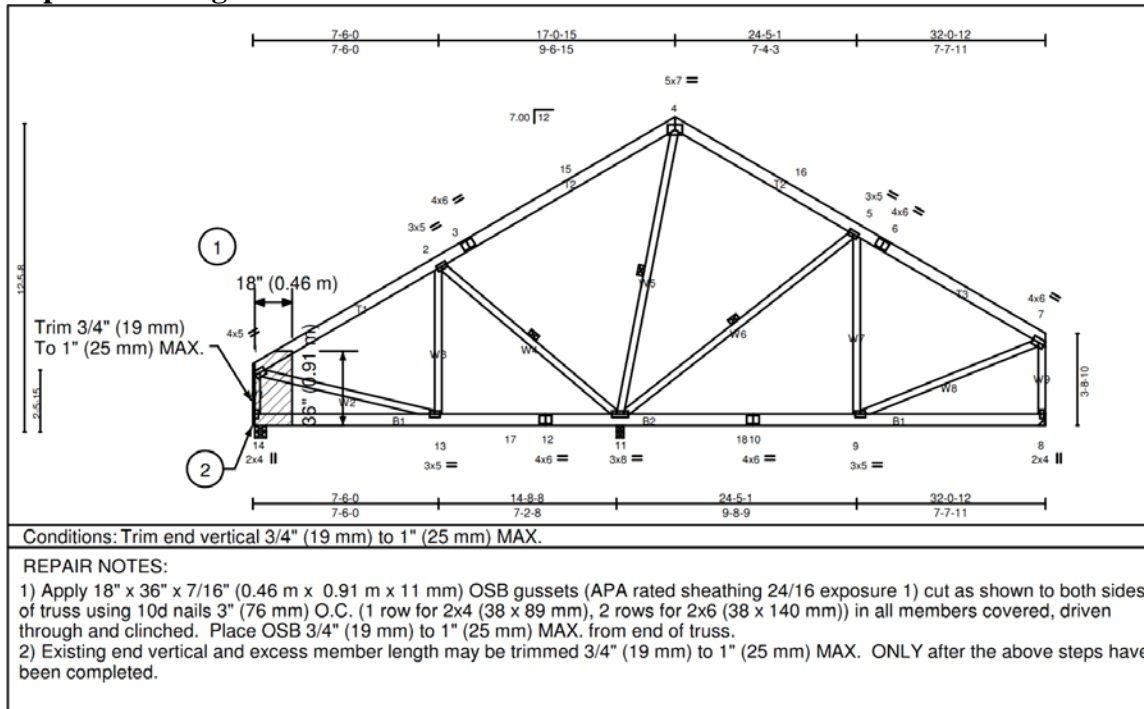

Discussion

This repair is an example of a relatively small change required in the horizontal dimension of the truss often caused by the supporting wall not being exactly where it was supposed to be or there was a misinterpretation of the plans. As an example of a possible misinterpretation, some plans may show the dimensions to the framing whereas others may have dimensions to the outside of sheathing resulting in a potential difference up to 1" (25 mm). A key question on repairs of this nature is whether any reinforcement needs to be applied to the truss when a small part is removed. A general rule of thumb is that if the trim does not damage any plates and the forces are relatively low then no reinforcement is required. It was decided to use small OSB gussets in this case because if the full 1" (25 mm) was trimmed off the end of the truss, there would be some damage to the truss plates on both joints at the heel.



Repair Techniques for Metal Plated Wood Trusses
A SunCam online continuing education course

Example 7-2 Remove Cantilever

Problem

The cantilever portion of this attic truss needs to be removed.

Repair Drawing

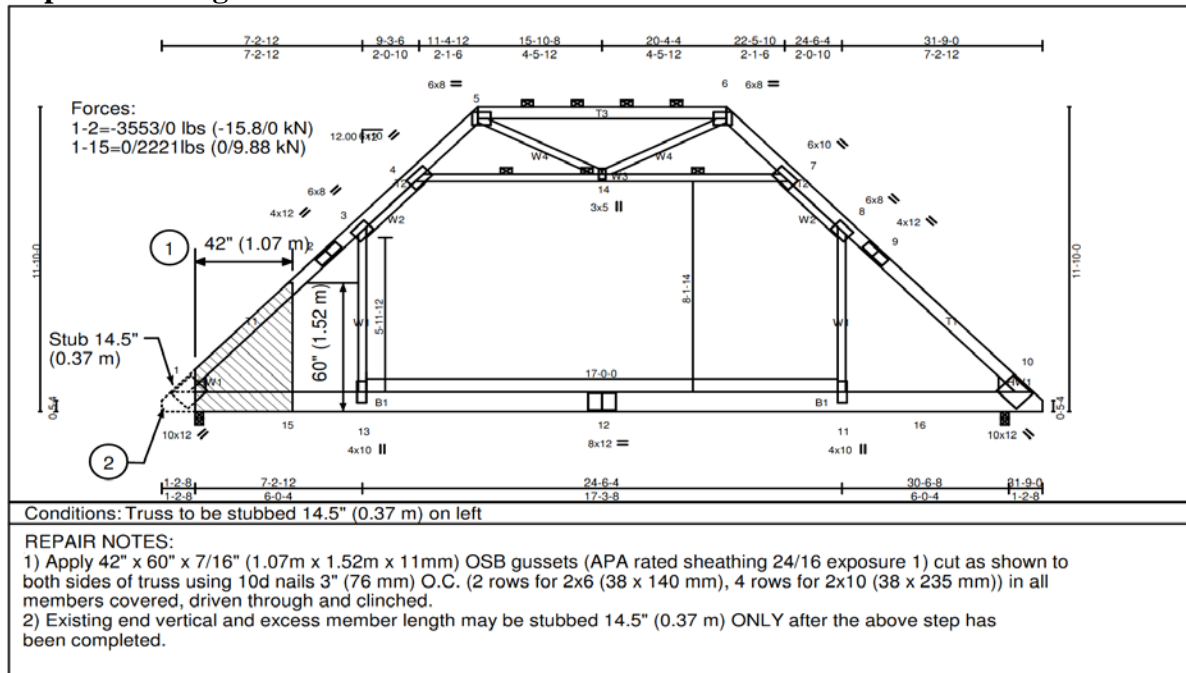

Discussion

Removing the cantilever portion of either a roof or floor truss is a relatively common modification. If there is a vertical web at the bearing causing at least three separate joints (one at the bearing on the bottom chord, one at the top chord above the bearing, and one or more joints in the cantilever) then usually the cantilever may be removed without any further reinforcement even though one or more plates in the cantilever may be completely removed. However, due to the large chord sizes of this attic truss, there was only one plate covering the bearing and the cantilever, and most of the single plate at the heel joint would be cut off when the cut was made. Therefore, additional reinforcement was needed.

From Table 3-1, the appropriate shear capacity is 173 lbs (0.77 kN) for a 10d nail with OSB gussets on both sides of a roof truss. The maximum compressive force in the top chord member from joint 1 to joint 2 is 3,553 lbs (15.8 kN) and the maximum tension force in the bottom chord member from joint 1 to joint 15 is 2,221 (9.88 kN). The top and bottom chord would require 21 and 13 nails, respectively. With 2 rows of nails in the top chord, the minimum development length would be 3' (0.91 m). From Table 5-1, the allowable shear of the OSB gusset is 1,980 lbs/ft of length. With the force in the top chord, one OSB gusset would only need to be 1.75' (0.53 m) to develop the full shear capacity. Therefore the connection is the controlling factor. The OSB gussets were oversized to provide additional rigidity for the joint.



Repair Techniques for Metal Plated Wood Trusses
A SunCam online continuing education course

Example 7-3 Substantial Stub of a Roof Truss

Problem

The truss needs to be stubbed and supported by a beam.

Repair Drawing

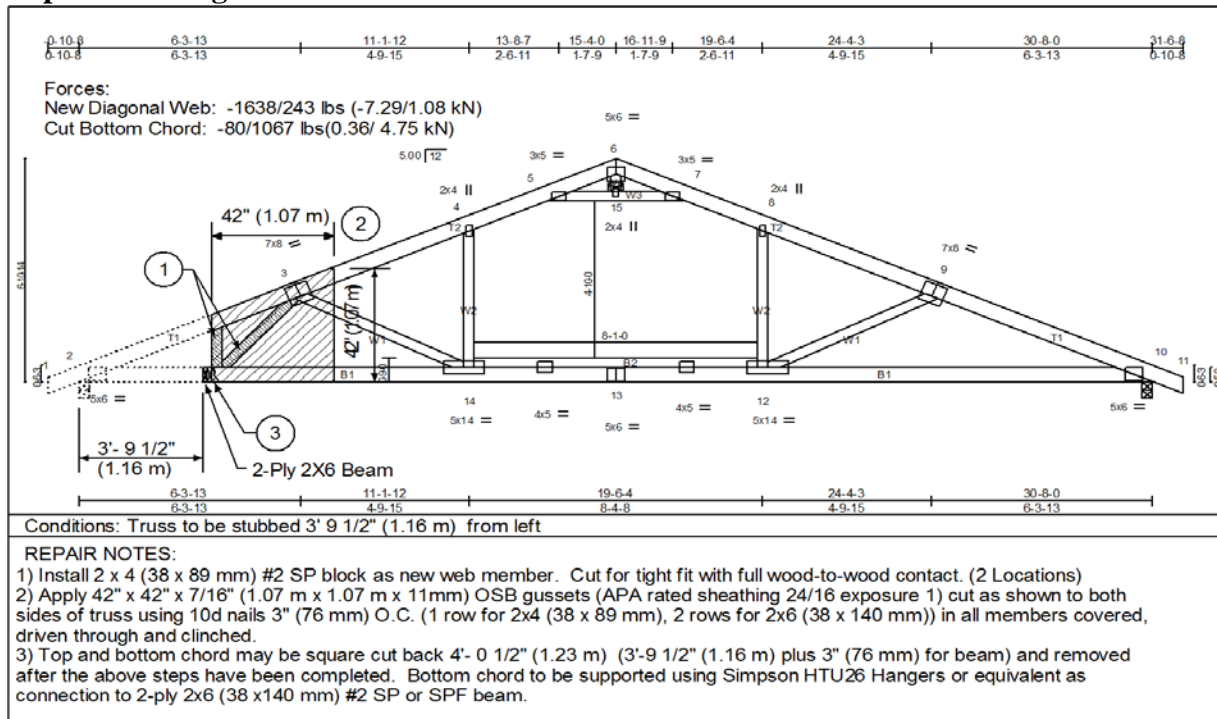

Discussion

When the stub location is not at a joint, additional members are usually required to make the truss structurally sound. After software modelling of the truss, it was determined that two the additional webs shown in the repair drawing were needed to transfer the forces to the bearing support. The specific solution for these types of repairs will vary based on stub location, truss span, chord size, and design loads.

The OSB gussets on a roof truss allow the double shear capacity of 173 lbs (0.77 kN) for a 10d nail as listed in Table 3-1. The top chord member from the new end of the truss to joint 3 and the new vertical member has a maximum force of less than 250 lbs (1.11 kN) and would have only required a minimum gusset size. However, the controlling force in the new diagonal web is a compressive force of -1638 lbs (-7.29 kN). The diagonal web would require 30" (0.76 m) of development length with the nails at 3" o.c (76 mm). Since the web was only 36" (0.91 m) long and would not allow the full development of two sets of OSB gussets, it was decided to size the OSB gussets to encompass all three joints involved in the truss repair.



Repair Techniques for Metal Plated Wood Trusses
A SunCam online continuing education course

Example 7-4 Floor Truss Stub

Problem

The floor truss needs to be shortened.

Repair Drawing

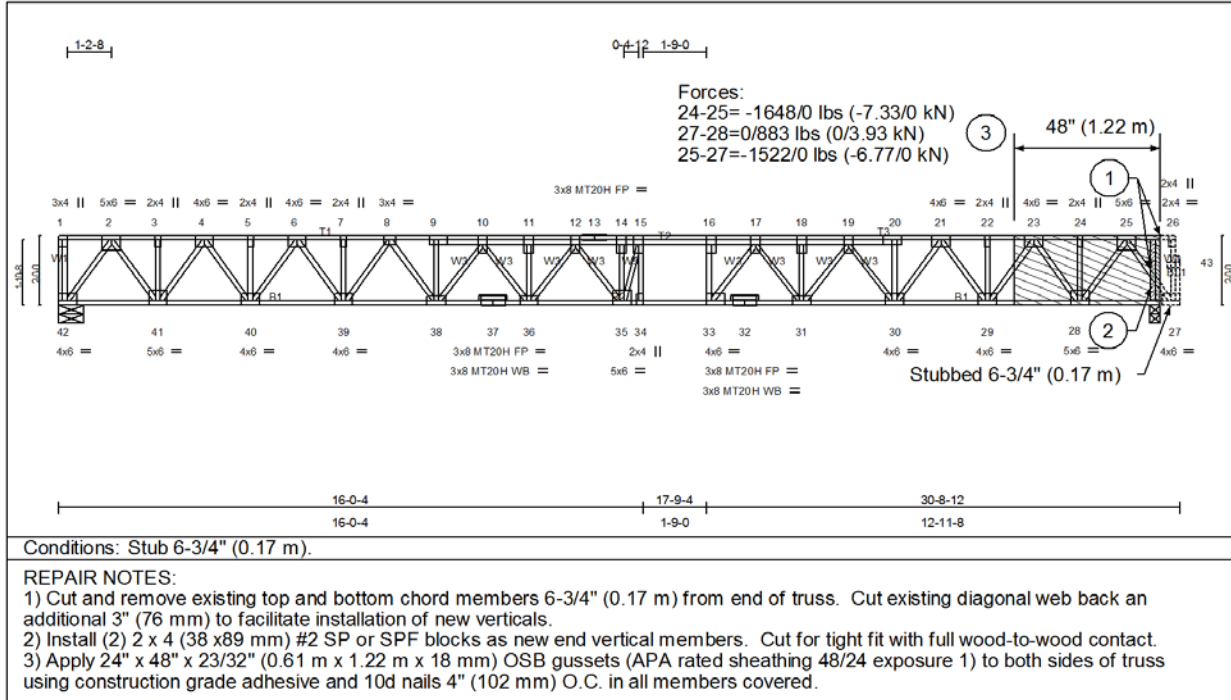

Conditions: Stub 6-3/4" (0.17 m).

REPAIR NOTES:

- 1) Cut and remove existing top and bottom chord members 6-3/4" (0.17 m) from end of truss. Cut existing diagonal web back an additional 3" (76 mm) to facilitate installation of new verticals.
- 2) Install (2) 2 x 4 (38 x 89 mm) #2 SP or SPF blocks as new end vertical members. Cut for tight fit with full wood-to-wood contact.
- 3) Apply 24" x 48" x 23/32" (0.61 m x 1.22 m x 18 mm) OSB gussets (APA rated sheathing 48/24 exposure 1) to both sides of truss using construction grade adhesive and 10d nails 4" (102 mm) O.C. in all members covered.

Discussion

New web members are required for this stubbed floor truss to be structurally sound similar to the prior roof truss repair in Example 7-3. The existing diagonal web member must be cut back further than the stub length in order to install the new vertical web members. From Table 3-1, a 10d nail has a shear capacity of 91 lbs (0.40 kN) for a floor truss with 23/32" (18 mm) OSB gussets. The diagonal web member has a controlling compressive force of -1522 (-6.77 kN) and would require 34" (1.93 m) of development length per side with the nails at 4" (102 mm) o.c. The web itself is not long enough to develop the required nailing as is often the case in floor truss repairs. However, if the forces in the top and bottom chord members of a floor truss can be developed with the reinforcement, then it is not always necessary to develop the full connection for each web. It is recommended to make the height of the OSB gussets match the height of the truss to cover both the top and bottom chord member when doing floor truss repairs. The perimeter nailing creates a box beam that significantly increases the stiffness of the truss in the repair area and largely eliminates the need to develop the full connection in each web. The controlling force is the -1648 lbs (-7.33 kN) compressive force in the top chord in the panel adjacent to the modified region. This would require 38" of development length per side. In this case 48" (1.22 m) wide OSB gussets were applied to fully encapsulate the region.



Repair Techniques for Metal Plated Wood Trusses
A SunCam online continuing education course

Example 7-5 Small Floor Truss Extension

Problem

The floor truss needs to be extended a total of 3”.

Repair Drawing

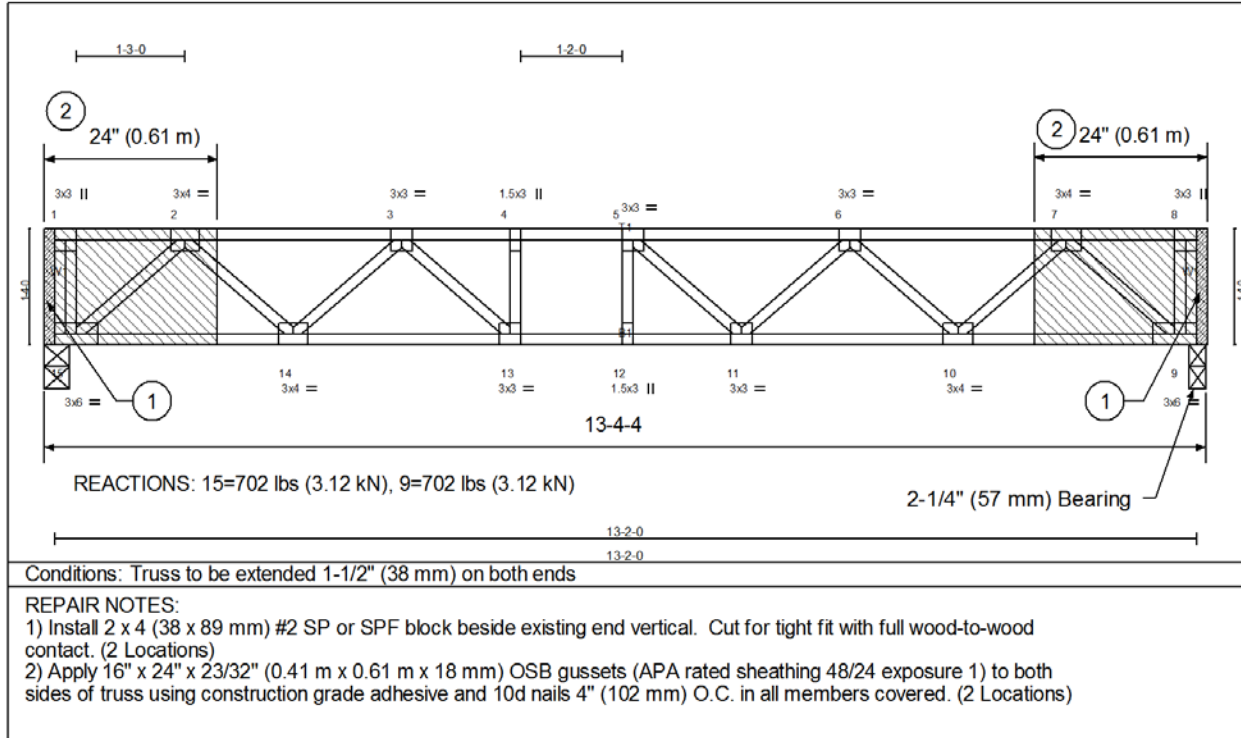

Discussion

The minimum recommended bearing width for most floor truss is 1 1/2" (38 mm). If the floor truss is shorter than the required application but still long enough to achieve the minimum recommend bearing width then usually no repair would be required. In this case the bearing surface at the right end was already reduced to 2 1/4" (57 mm) because the wall was being shared with other structural elements. Any additional reduction in the bearing surface would create an unacceptable bearing condition. Also, this truss was used in a multi-story structure and there was concern about load transfer from the upper floors if one end of the truss did not extend the full width of the bearing surface. It was therefore decided to center the truss and extend both ends 1 1/2" (38 mm) rather than extending one end by the required 3" (76 mm).

Centering the truss between the two bearing surfaces allowed for the simplistic nature of this repair detail. Since the existing truss was partially sitting on the bearing surface at both ends and the span is relatively small, the OSB gussets only needed to provide load transfer into the block of about half the reported reaction. Shifting the truss as shown was possible because there was some flexibility in the chase location. Had the chase location been fixed, an alternative single end extension solution would have been required.



Repair Techniques for Metal Plated Wood Trusses
A SunCam online continuing education course

Example 7-6 Roof Truss Extension with a High Heel

Problem

The roof truss needs to be extended a total of 3 1/2" (89 mm) on the left end.

Repair Drawing

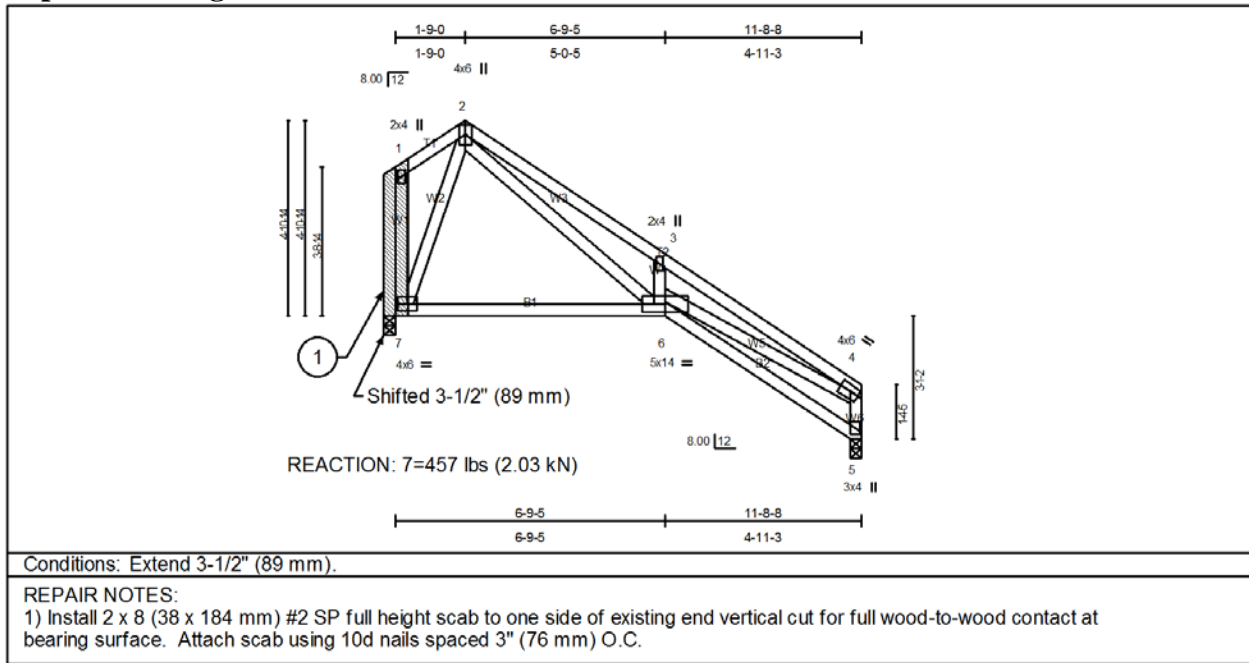

Discussion

Unlike the previous floor truss of Example 7-5, a roof truss cannot be centered between the bearing surfaces because the slopes of both the top and bottom chord members must align with the adjacent trusses. The 3 1/2" (89 mm) extension corresponds to a 2x4 (38 x 89 mm) frame wall and is the most common dimension for either stubbing or extending a truss. The cause of the required adjustment is usually due to a change in the vertical placement of a beam. A truss needs to be 3 1/2" (89 mm) longer if the beam is dropped and the truss is to bear on top of the beam than if the beam was flush and the truss sits in a hanger attached to the face of the beam. If the vertical placement of the beam is different than anticipated then the length of the truss needs to be adjusted by width of the beam

The original truss had a reaction of 457 lbs (2.03 kN) which equals the amount of shear transfer that is required. The 2x8 (38 x 184 mm) repair was chosen because of its simplicity and the fact that it can develop the required connection with the end vertical, extend the truss the required 3 1/2" (89 mm), and transfer the forces into the bearing surface. According to Table 3-1, the appropriate nail shear capacity for a roof application with SP lumber would be 122 lbs (0.54 kN). The development length would only need to be 15" (0.38 m), but to minimize the effects of the eccentric load, the scab was specified to be the full height of the end vertical.



Repair Techniques for Metal Plated Wood Trusses
A SunCam online continuing education course

Example 7-7 Alternate Roof Truss Extension with a High Heel

Problem

The roof truss needs to be extended a total of 2 1/2" (64 mm) on the right end.

Repair Drawing

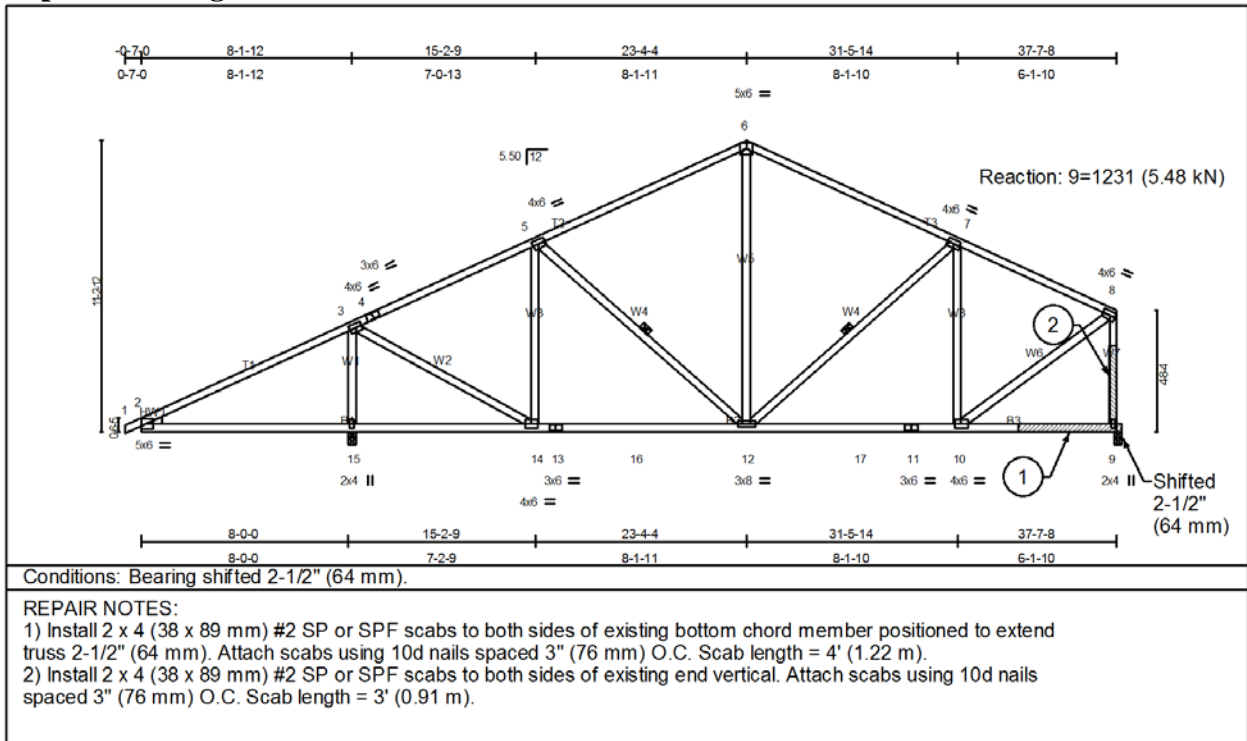

Discussion

This example is presented as an alternate solution to Example 7-6 for relatively short extensions of roof trusses with raised heels. Even though the reaction was substantially higher, it was not the deciding factor for the repair solution. In both examples the scab on the end vertical member allows development of the connection almost directly above the bearing surface. The advantage of using the two 2x4 (38 x 89 mm) scabs as opposed to the 2x8 (38 x 184 mm) scab from the previous example is the material availability at a jobsite.

According to Table 3-1, the shear value of a 10d nail in a roof application where one member is SPF lumber is 106 lbs (0.47 k N). The required vertical development length would be 3' (0.91 m) in total. However, it was decided to apply the repair to both sides to increase the shear capacity of the horizontal scabs and to eliminate eccentricity. The limit of the extension for this type of repair would be approximately 3 1/2" (89 mm) without considering the shear capacity of the scabs. Example 7-9 will demonstrate not only shear but also moment calculations for a larger extension.



Repair Techniques for Metal Plated Wood Trusses
A SunCam online continuing education course

Example 7-8 Roof Truss Extension with a Low Heel

Problem

The roof truss needs to be extended a total of 3 1/2" (89 mm) on the left end and a 1' overhang needs to be added.

Repair Drawing

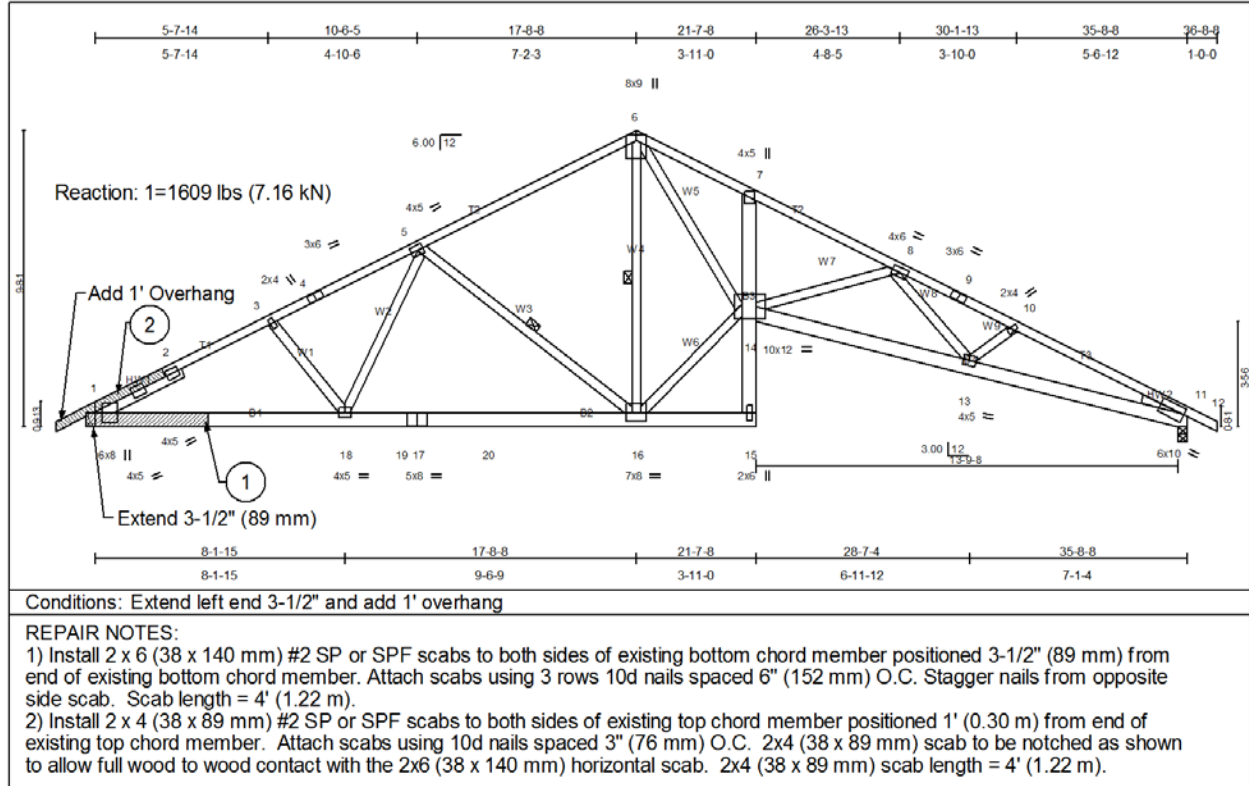

Discussion

The additional need for the overhang was advantageous to this repair because it allowed for additional nailing above the bearing surface. The scabs working in tandem create a similar result as a truss heel allowing the compressive force in the top chord to be transferred into the bearing surface without creating a critical shear location. From Table 3-1, the shear capacity of a 10d nail in a roof application with SPF lumber is 106 lbs (0.47 kN). Therefore, 16 nails are required to transfer the 1609 lbs (7.16 kN) reaction. Due to the geometry of the joint, some of the nails in bottom chord scab count toward the required total with the remainder being installed in the top chord. A discussion for why the bottom chord scab is longer than the required development length is provided in Example 7-9.

If the repair had been only to add an overhang, it would have been sufficient to apply only a single-sided top chord scab. As a general rule of thumb when creating an overhang, the lumber scab should come back along the top chord at least twice the slope distance of the overhang.



Repair Techniques for Metal Plated Wood Trusses
A SunCam online continuing education course

Example 7-9: Large Extension with Straps

Problem

The roof truss needs to be extended 14 1/2" (0.37m) on the left end.

Repair Drawing

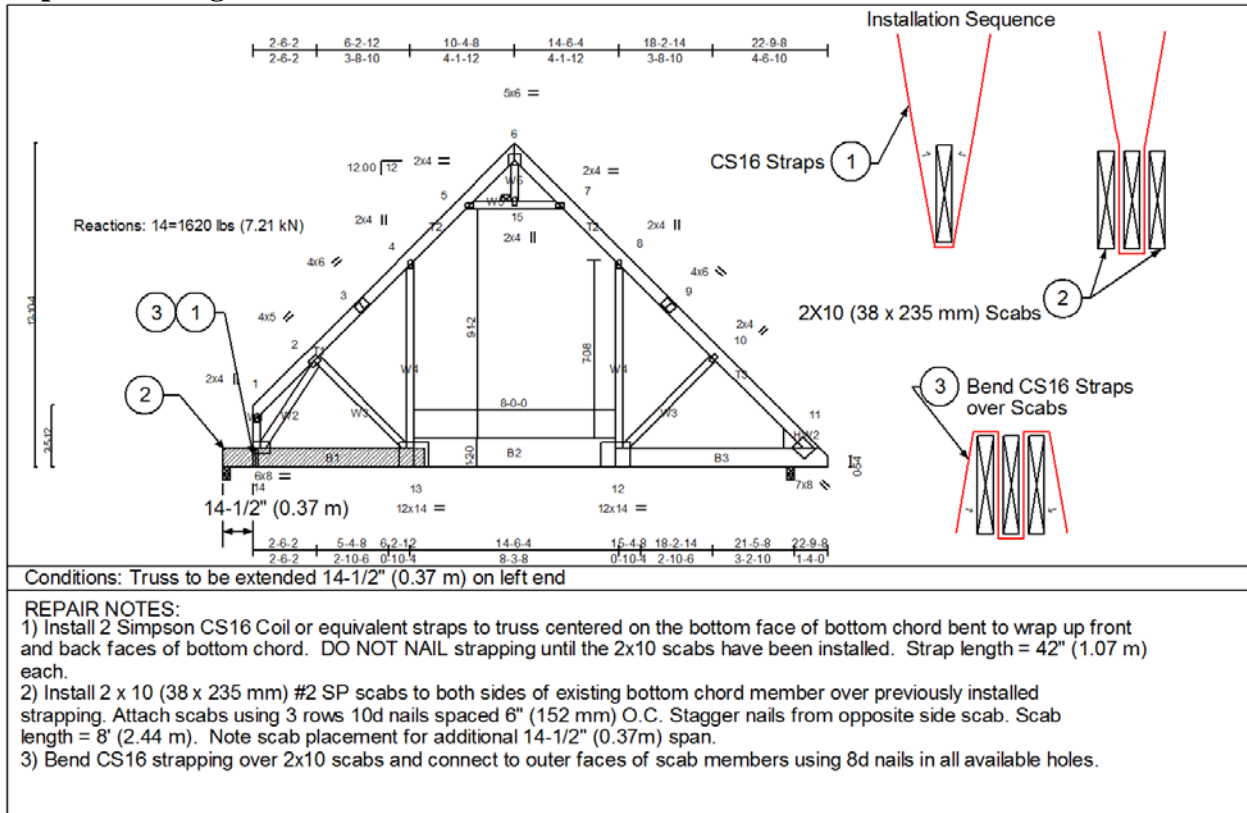

Discussion

The principle concept in this repair is that the new scab members can be modeled as a simply supported beam with the truss reaction applied as a point load at the appropriate distance from the new bearing location. The metal straps which weave up and down between the members act as hangers to transfer the reaction from the base truss to the 2x10 (38 x 235 mm) scabs which act a beam, and the nailed connection transfers the beam reaction force at the right end back into the base truss. The order of the installation steps is critical in this repair design. The metal straps have to be applied to the base truss to form a U- shape before the scabs are applied. Once the scab members are applied, the straps are bent over the scab members forming the M shape shown in the detail and creating the hanger connection. The straps would nearly be useless if the scabs were installed first since the straps would be horizontal at the base of the truss and would have to take a deflected shape before actually carrying any load. The straps are required because the reaction of the base truss would act as a concentrated load on the beam. Using nails alone to transfer the load would force the nail pattern into a cluster that may cause the wood members to split.



Repair Techniques for Metal Plated Wood Trusses
A SunCam online continuing education course

The design of the beam can be approached similar to a simply supported beam model with an off-center concentrated load. However, the connection to the truss generates a moment that can be modeled as a force couple which in this case works out to be 327 lbs (1.45 kN). The diagram to the right shows the free-body, shear, and moment diagrams for the beam. The allowable shear stress, f_v , for 2x10 (38 x 235 mm) SP No. 2 is 175 psi (1,207 kN/m²) and the allowable bending stress, f_b , is 800 psi (5,516 kN/m²) as given by the 2015 edition of the NDS Supplement. According to NDS-2015 equation 3.4-1 the allowable shear capacity of the wood beam is:

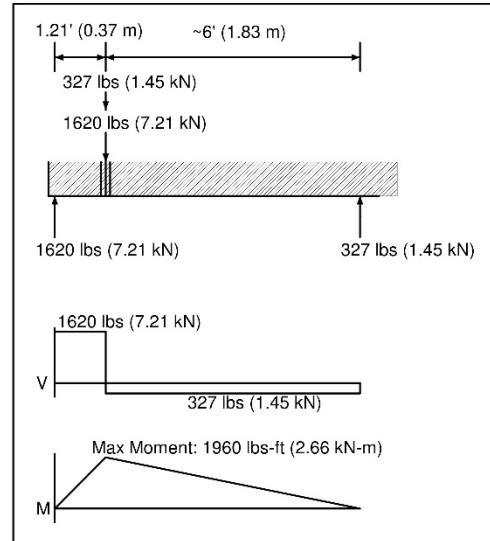

$$V = (2/3) \cdot f_v \cdot b \cdot d$$

$$V = (2/3)(175 \text{ psi})(1.5'' \cdot 2 \text{ pieces})(9 \frac{1}{4}'')$$

$$=(2/3)(1,207 \text{ kN/m}^2)(0.038 \text{ m} \cdot 2)(0.235 \text{ m})$$

$$V = 3,238 \text{ lbs (14.4 kN)}$$

The maximum allowable bending moment given by equation 3.3-1 of NDS-2015 is shown below. S is the section modulus which is $b \cdot d^2/6$ for a rectangular section where b is the horizontal dimension and d is the vertical dimension of the section.

$$M = f_b \cdot S = f_b \cdot b \cdot d^2/6$$

$$M = (800 \text{ lb/in}^2) \cdot (1.5'' \cdot 2 \text{ pieces}) \cdot (9 \frac{1}{4}'')^2/(12 \text{ in/ft} \cdot 6)$$

$$= (5,516 \text{ kN/m}^2) \cdot (0.038 \text{ m} \cdot 2 \text{ pieces}) \cdot (0.235 \text{ m})^2/6$$

$$M = 2,852 \text{ lbs-ft (3.86 kN-m)}$$

The allowable shear and moment for the 2 member beam is sufficient to carry the reaction of the base truss. From the 2015-2016 Wood Construction Connectors (C-C-2015) publication by Simpson Strong-Tie, the CS16 is a 16 gauge (1.59 mm) strap that is 1.25'' (31.8 mm) wide and has a tension capacity of 1,705 lbs (7.58 kN) at a DOL (Duration of Load) of 1.60. The application of this repair would require a DOL of 1.15 reducing the effective tension capacity of the strap to 1,225 lbs (5.45 kN). Two straps are required to transfer the 1,947 lbs (8.66 kN) reaction plus the force couple. Any equivalent strap could be used but the CS16 was specified because the Simpson publication specifically allows this series of straps to be cut to the required length with appropriate adjustments if the full development length is not achieved.

For this repair, the scab length was chosen so that the right end of the scab was past the next bottom chord joint for two reasons. The first reason is that the joints are the strongest part



Repair Techniques for Metal Plated Wood Trusses
A SunCam online continuing education course

of the truss. If possible, any repair that changes the model of the truss and therefore changes the forces in the members should be attached at a joint to produce the minimal effect on the truss. The second reason is the basic principle of a lever arm in that an increase in the length of the lever arm means a decrease in the required connection at that end. The minimum length of the scabs should be 3x the extension distance so that there is at least 2x the extension distance beyond the original truss support. In this example, the distance that the scabs went beyond the original truss support was more than 4x the extension distance allowing the force couple at the right end of the beam model to be easily resolved with a nailed connection.



Repair Techniques for Metal Plated Wood Trusses
A SunCam online continuing education course

Chapter 8 – Minor Modifications

This chapter covers truss repairs that add to but do not require cutting or modifying the original truss. These repairs include changes in bearing location, internal additions to the webs such HVAC platforms, and perimeter alterations of the truss to meet required geometry. These perimeter repairs usually deal with vertical changes in geometry as opposed to the horizontal extension repairs addressed in Chapter 7.



Repair Techniques for Metal Plated Wood Trusses
A SunCam online continuing education course

Example 8-1 Bearing Location Change

Problem

The roof truss was set backwards causing both interior bearing supports to be in a different location than originally designed.

Repair Drawing

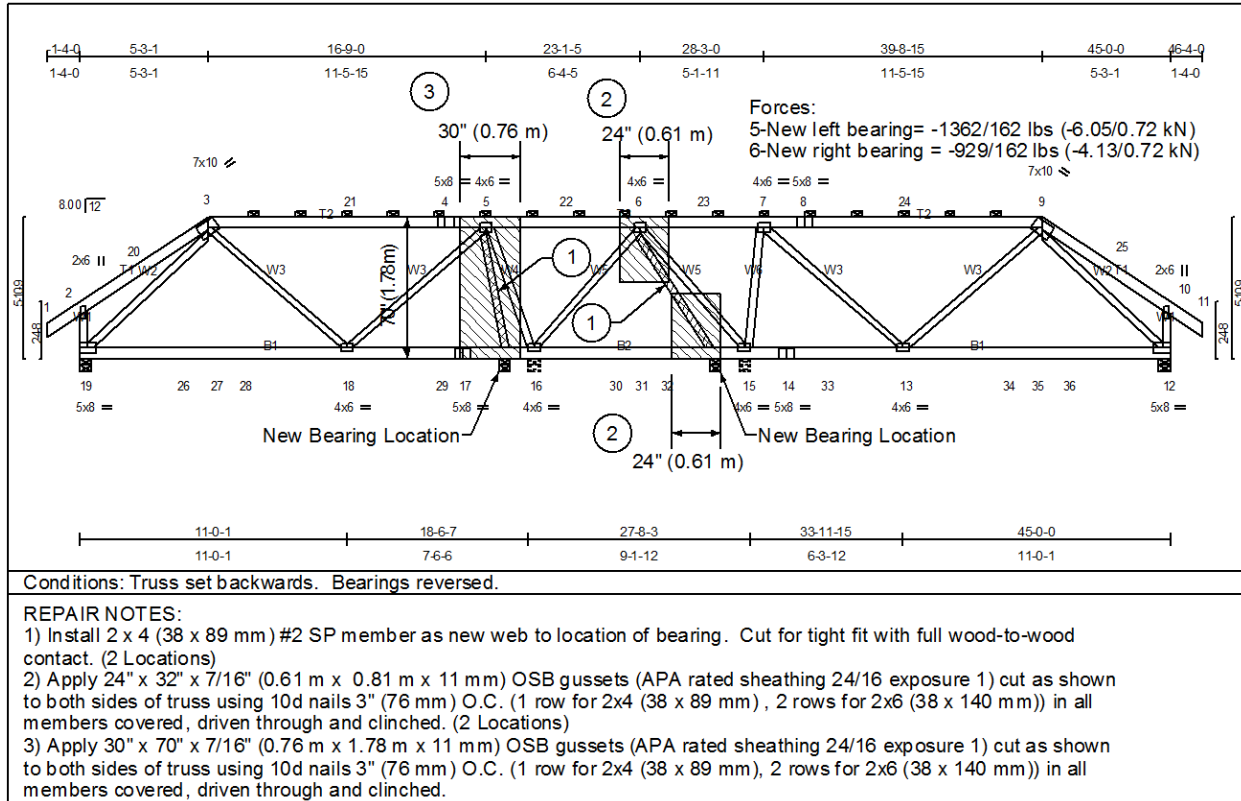

Discussion

Setting trusses backwards is not uncommon when the truss profile is nearly symmetric and there is some subtle difference such as an off-center interior bearing location. When cost effective, perfectly symmetric trusses are a desirable option to avoid this installation error. However, the trade-off is the extra cost of adding more webs if the bearings are not in symmetric locations versus the ease of installation. For the truss shown, several additional webs would have been needed to make the truss symmetric with two interior bearings and so the symmetric design was not practical.

To complete the repair, two webs were added to the truss at the revised bearing locations. The forces in the new webs are shown above. The development length for the forces in the new web on the left would require the OSB gussets to overlap, so the decision was made to make the gussets the full height of the truss.



Repair Techniques for Metal Plated Wood Trusses
A SunCam online continuing education course

Example 8-2 Pad up Top Chord a Small Distance

Problem

The roof truss was designed too short vertically for the required application.

Repair Drawing

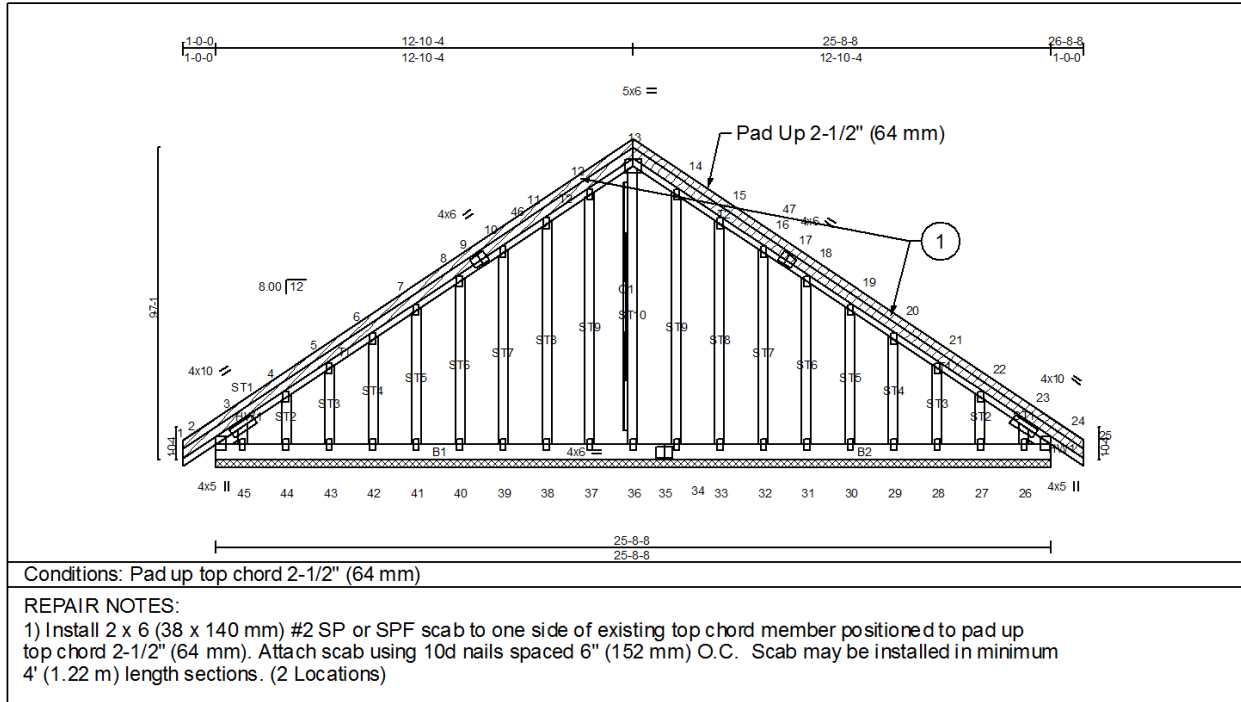

Discussion

This repair was required due a design error where the heel height was not set correctly. The distance the gable truss needed to be raised was small so a larger scab member applied to one side was sufficient. This repair would have been the same for a structural truss because the scab member that would be attached to the roof sheathing provides adequate bracing of the top chord members.

In general, larger dimensional lumber members can be applied as a scab to the side of the top chord to make up the difference in height as long as most of the original chord depth is covered and the connection is adequate. The recommended maximum distance for offsetting the roof sheathing from the top chord of the truss are that a 2x6 (38 x 140 mm) scab could be used to raise a 2x4 top chord member up no more than about 3" (73 mm), a 2x8 (38 x 184 mm) about 4 1/2" (114 mm), and a 2x10 (38 x 235 mm) about 6" (152 mm). It is not recommended to use this repair technique to raise the top chord of a truss more than 6". These recommended distances for the scabs to raise the top chord plane are perpendicular to the slope of the top chord so the actual allowable vertical height adjustment would vary with the pitch of the roof.



Repair Techniques for Metal Plated Wood Trusses
A SunCam online continuing education course

Example 8-3 Pad up Top Chord a Large Distance

Problem

The right half of the roof truss was designed too short vertically for the required application.

Repair Drawing

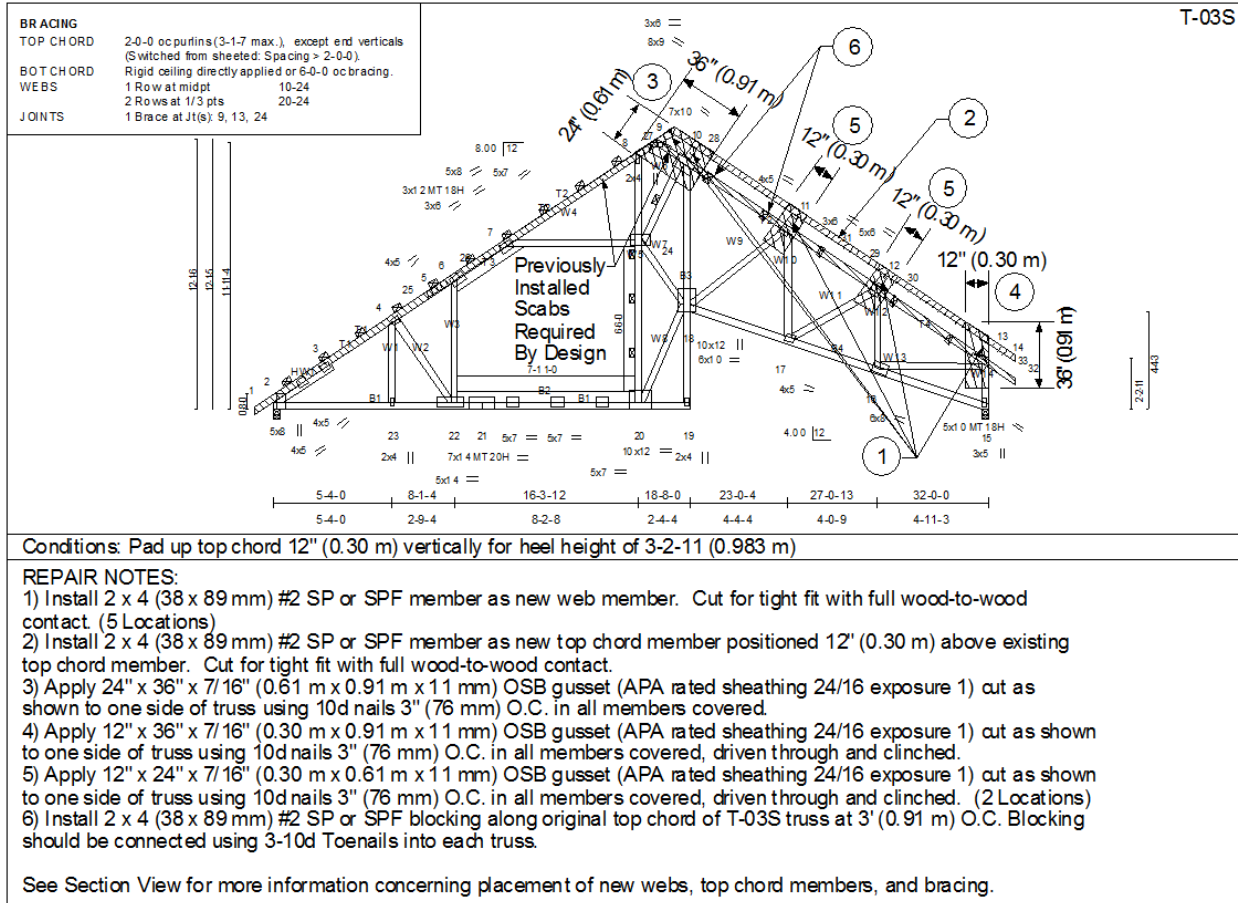

Discussion

This truss was in a series of attic trusses where the small room on the left is used for HVAC equipment. This particular truss was named T-03S and was designed to allow a 26" (0.97 m) gap between the trusses for a pull-down stair. The top chord scabs were supplied as an agreement between the truss manufacturer and the builder to prevent the over spanning of the roof sheathing. The problem arose when the incorrect heel height was used at the right end of the truss. The section view on the following page shows two T-03S trusses installed between other trusses and it depicts the substantial difference in height with respect to the adjacent trusses.

Unlike the Example 8-2, the built up top chord for this repair provides almost no bracing for the existing top chord. The bracing note for this truss states that the purlins must be installed



Repair Techniques for Metal Plated Wood Trusses
A SunCam online continuing education course

every 3'-1 7/16" (0.95 m) maximum to prevent buckling due to the compressive forces in the member. The 2' (0.61 m) spacing is an industry standard for applying purlins along a flat top chord which is not necessary in this case. To get the correct profile, new webs and new top chord members were installed with an OSB gusset on one face at each joint. In order to brace the original top chord members of each the T-03S trusses, 2x4 (38 x 89 mm) horizontal and diagonal bracing members were installed at 3' o.c. to the top chords of the adjacent trusses.

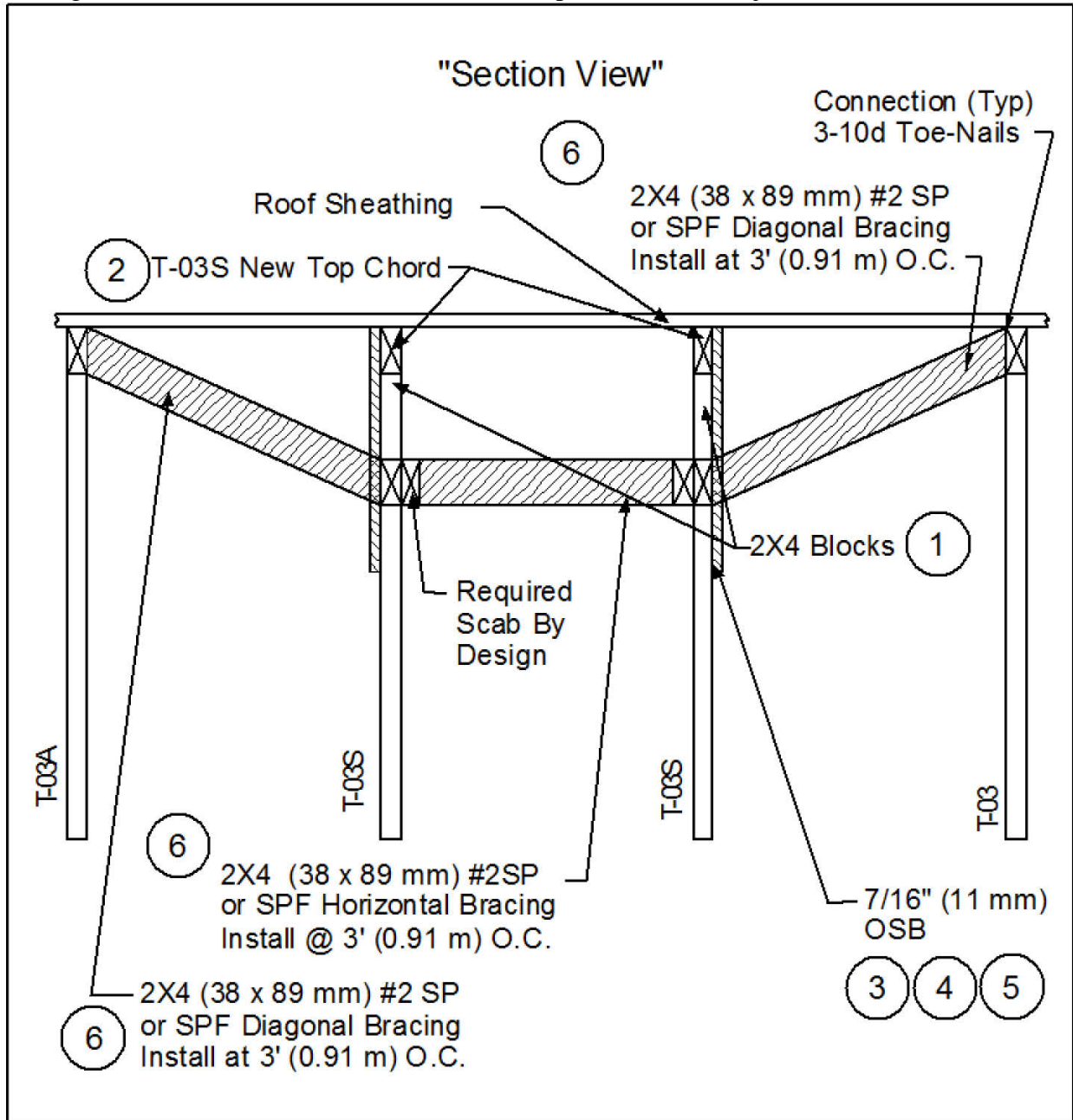



Repair Techniques for Metal Plated Wood Trusses
A SunCam online continuing education course

Example 8-4 Add HVAC Platform

Problem

An HVAC platform was needed within the profile of the truss.

Repair Drawing

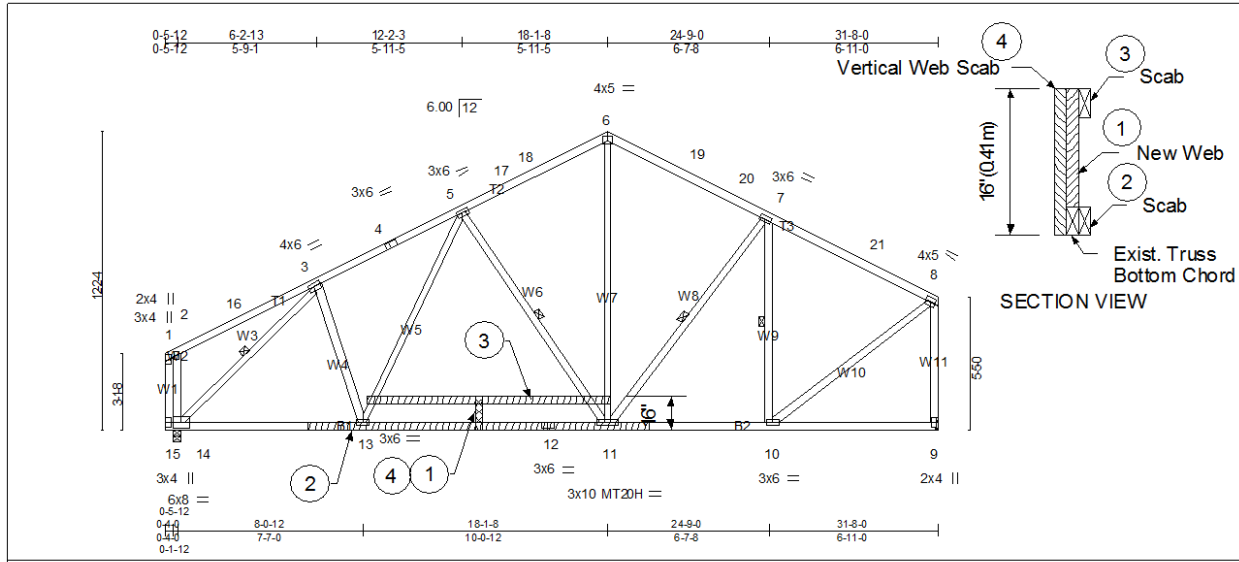

Conditions: Truss to support HVAC platform

REPAIR NOTES:

- 1) Install 2 x 4 (38 x 89 mm) #2 SP or SPF member as new vertical web member. Cut for tight fit with full wood-to-wood contact.
- 2) Install 2 x 4 (38 x 89 mm) #2 SP or SPF scab to front side of existing bottom chord member. Attach scab using 10d nails spaced 3" (76 mm) O.C. Scab length = 14' (4.27 m).
- 3) Install 2 x 4 (38 x 89 mm) #2 SP or SPF scab to front side of existing truss. Attach scab using clusters of (3) 10d nails at each member intersection. NOTE scab position 16" (0.41 m) above bottom of truss. Scab length = 10' (3.05 m).
- 4) Install 2 x 4 (38 x 89 mm) #2 SP or SPF vertical scab to back side of new web member. Attach scab using 10d nails spaced 3" (76 mm) O.C. along web member and cluster of (3) 10d nails at chord member. Scab length = 16" (0.41 m).

Discussion

The space within a roof truss is a common area to place HVAC units. If the location of the HVAC unit is known prior to the fabrication, then the design of the truss can accommodate the unit. Often, a platform similar to the one shown in this repair would be built into the truss to raise the platform above the insulation. According to Table R301.5 of the IRC2015, any horizontal area of the truss that is raised above the insulation and can fit a box 42" (1.07 m) tall by 24" (0.61 m) wide should be loaded with 20 psf (0.96 kN/m²) live load. When this load was added to the truss with a raised platform, the bottom chord required reinforcement because the CSI (Combined Stress Index) of that member exceeded 1.0. Once the bottom chord scab length was determined to be 14' (4.27 m) as shown, it was decided that a scab on the side of the truss at the elevation of the platform would be best solution. The vertical web was added to transfer load down to the bottom chord, and the vertical scab was added to complete the connection. If the bottom chord reinforcement was not required then the repair could have entailed adding the vertical web and the horizontal raised bottom chord members in the plane of the truss with OSB gussets at the three joints.



Repair Techniques for Metal Plated Wood Trusses
A SunCam online continuing education course

Chapter 9 – Major Modifications:

This chapter covers truss repairs that require altering the original truss structure and includes three main types: 1) the top chord is to be cut because it doesn't match the adjacent trusses and would be protruding through the roof, 2) some webs are to be moved or removed to allow more space inside the truss for utilities or living space, and 3) the bottom chord is to be cut to allow for stair access in the attic space. Design errors, lack of communication, and installation errors are the primary reasons these types of modifications occur.

This chapter does not repeat stub truss repairs which were covered in Chapter 7 or volume ceiling changes which will be covered in Chapter 10 in the third part of this course series. The major modification truss repairs are different from the minor modification repairs that was discussed in Chapter 8 in that this chapter deals with trusses that need to be cut in the process of resolving the issue, whereas the previous chapter only dealt with repairs where something had to be added to but without damaging the original truss.



Repair Techniques for Metal Plated Wood Trusses
A SunCam online continuing education course

Example 9-1 Reduce the Height of a Gable Truss

Problem

A raised beam interfered with the gable truss.

Repair Drawing

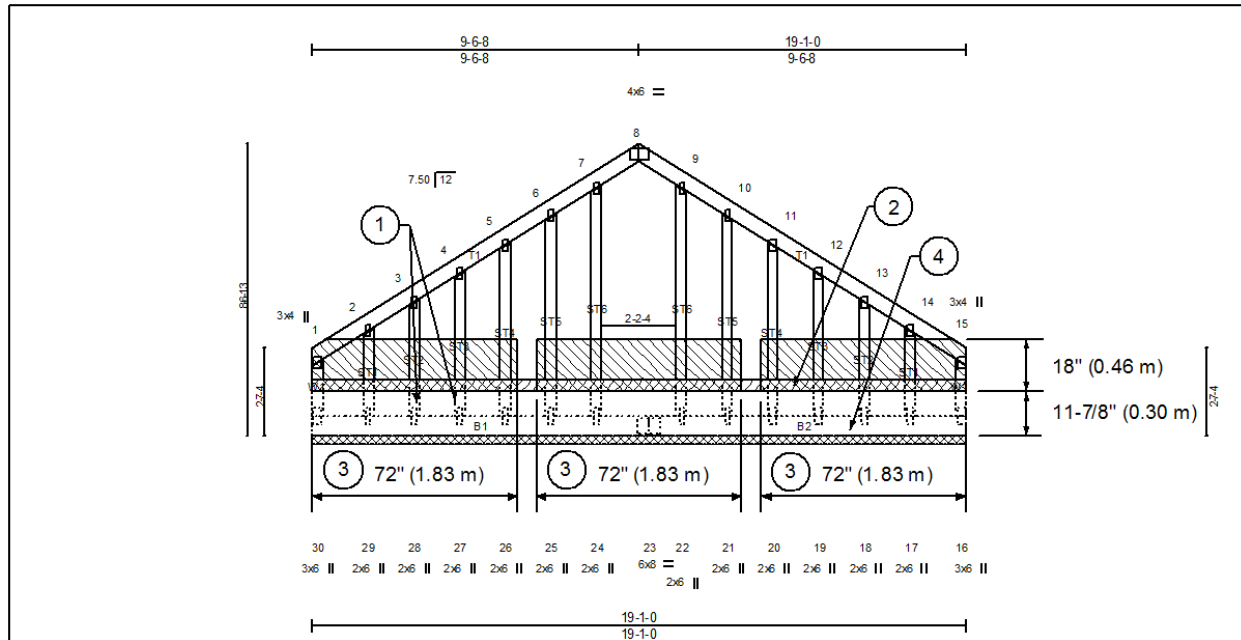

Conditions: Raise bottom chord of truss 11-7/8" (0.30 m)

REPAIR NOTES:

- 1) Cut existing studs back as needed to facilitate installation of new bottom chord member. (14 Locations)
- 2) Install 2 x 4 (38 x 89 mm) #2 SP or SPF block as new bottom chord member. Cut for tight fit with full wood-to-wood contact
- 3) Apply 18" x 72" x 7/16" (0.46 m x 1.83 m x 11 mm) OSB gusset (APA rated sheathing 24/16 exposure 1) cut as shown to one side of truss using 10d nails 3" (76 mm) O.C. (1 row for 2x4, 2 rows for 2x6) in all members covered, driven through and clinched. If clinching of nails is not possible connect gusset to truss using one of the following: #10 x 2" (5.2 x 51 mm) wood screws 3" (76 mm) O.C., 6d (2.5 x 51 mm) nails 3" (76 mm) O.C., or 1-3/4" x 16ga. (1.6 x 44 mm) staples at 3" (76 mm) O.C. (3 Locations)
- 4) Existing bottom chord member may be removed ONLY after the above steps have been completed.

Discussion

This truss repair resulted because the builder needed to place a continuous beam across the garage to complete the portal framing. When a gable truss is too tall, the height adjustment can be made either to the top chord or to the bottom chord depending on the stage of construction and complexity of either repair. In this case, the repair to the bottom chord was chosen because of the simplicity that option presented. For gable trusses, the OSB gussets are sized based on geometric constraints rather than the force in each member as with normal structural trusses, and the three gussets shown proved to be an efficient way to cover all of the stud members.

There are more options provided in the connection of the gussets to the gable truss than for other trusses because if the truss is already erected including the exterior sheathing and siding, the 10d nails would potentially penetrate and damage the siding.



Repair Techniques for Metal Plated Wood Trusses
A SunCam online continuing education course

Example 9-2 Lower Top Chord Section

Problem

The middle sloping section of the top chord is too tall for the application and must be lowered.

Repair Drawing

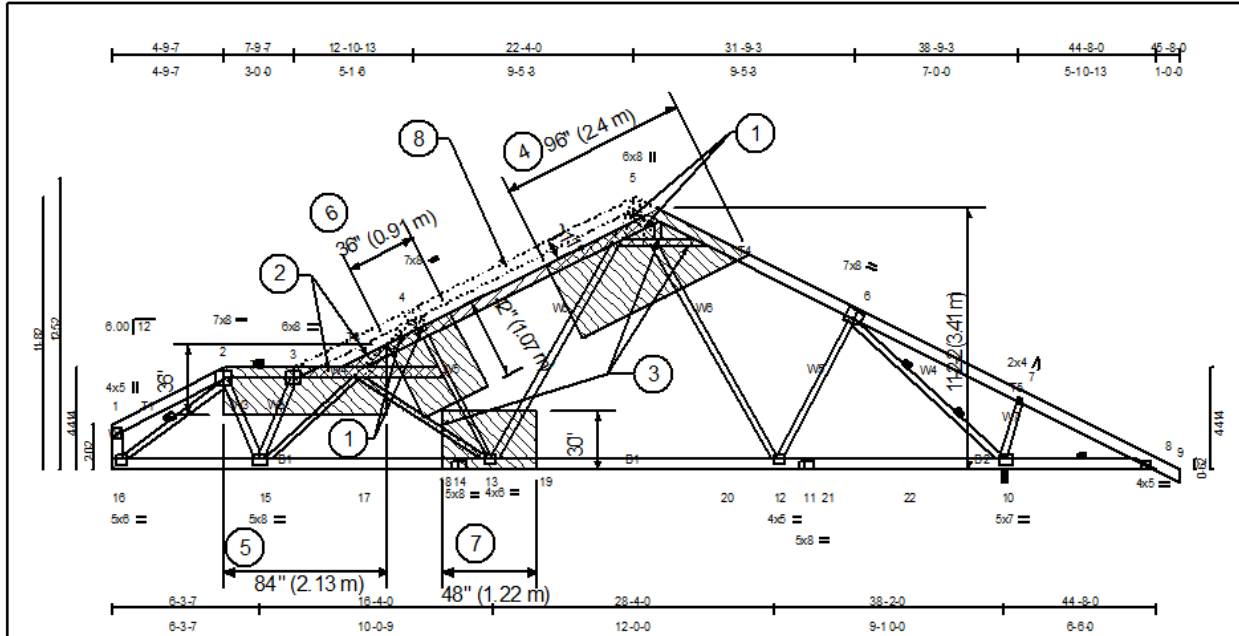

Conditions: Top chord to be lowered for overall height of 11-2-2 (3.41 m)

REPAIR NOTES:

- 1) Cut and remove section of existing web members as shown to facilitate installation of new truss members. (4 Locations)
- 2) Install 2 x 6 (38 x 140 mm) #2 SP block as new top chord member. Cut for tight fit with full wood-to-wood contact. (2 Locations)
- 3) Install 2 x 4 (38 x 89 mm) #2 SP or SPF block as new web member. Cut for tight fit with full wood-to-wood contact. (3 Locations)
- 4) Apply 96" x 42" x 7/16" (2.44 m x 1.07 m x 11 mm) OSB gussets (APA rated sheathing 24/16 exposure 1) cut as shown to both sides of truss using 10d nails 3" (76 mm) O.C. (1 row for 2x4 (38 x 89 mm), 2 rows for 2x6 (38 x 140 mm)) in all members covered, driven through and clinched
- 5) Apply 84" x 36" x 7/16" (2.13 m x 0.91 m x 11 mm) OSB gussets (APA rated sheathing 24/16 exposure 1) cut as shown to both sides of truss using 10d nails 3" (76 mm) O.C. (1 row for 2x4 (38 x 89 mm), 2 rows for 2x6 (38 x 140 mm)) in all members covered, driven through and clinched
- 6) Apply 36" x 42" x 7/16" (0.91 m x 1.07 m x 11 mm) OSB gussets (APA rated sheathing 24/16 exposure 1) cut as shown to both sides of truss using 10d nails 3" (76 mm) O.C. (1 row for 2x4 (38 x 89 mm), 2 rows for 2x6 (38 x 140 mm)) in all members covered, driven through and clinched
- 7) Apply 30" x 48" x 7/16" (0.76 m x 1.22 m x 11 mm) OSB gussets (APA rated sheathing 24/16 exposure 1) cut as shown to both sides of truss using 10d nails 3" (76 mm) O.C. (1 row for 2x4 (38 x 89 mm), 2 rows for 2x6 (38 x 140 mm)) in all members covered, driven through and clinched
- 8) Existing top chord member may be removed ONLY after the above steps have been completed.

Discussion

The complexity of this repair justifies a remodeling of the truss design in order to determine the forces in all members based on the revised member placement. The truss design drawing, a summary of forces, the required connection development length based on the shear capacity of a 10d nail for the double shear case from Table 3-1, and the minimum OSB gusset size based on the strength characteristics found in Table 5-1 for each member in this remodeled design are shown on the next page. As expected, the new top chord members generate the



Repair Techniques for Metal Plated Wood Trusses
 A SunCam online continuing education course

highest force, but because these are 2x6 (38 x 140 mm) members, more rows of nails are used which reduces the development length.

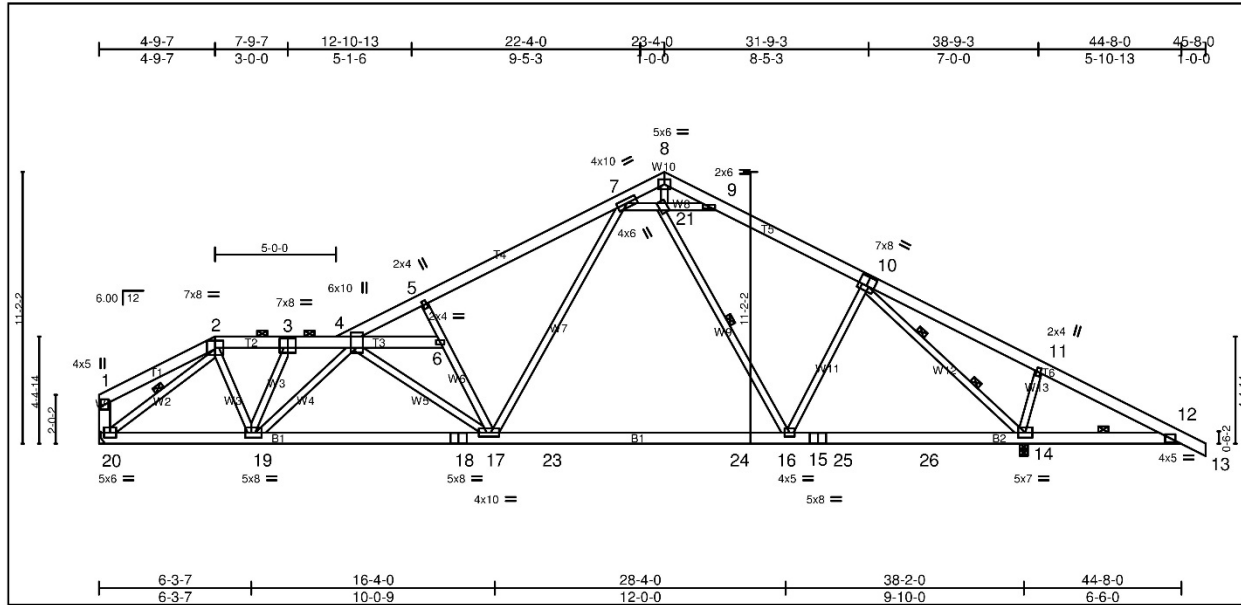

Member	Size		Controlling Force		No. Nails	No. Rows	Required Length		Min OSB Size	
	in	mm	lbs	kN			in	m	in	m
3-4	2x6	38 x 140	-2616	-11.64	16	2	24	0.61	16	0.40
4-5	2x6	38 x 140	-3111	-13.84	19	2	29	0.74	19	0.48
4-6	2x6	38 x 140	<250	<1.11	2	2	3	0.08	2	0.06
5-7	2x6	38 x 140	-3024	-13.45	18	2	27	0.69	18	0.47
7-8	2x6	38 x 140	-405	-1.80	3	2	5	0.13	2	0.06
3-19	2x4	38 x 89	-415	-1.85	3	1	9	0.23	3	0.06
4-19	2x4	38 x 89	-1305	-5.80	8	1	24	0.61	8	0.20
4-17	2x4	38 x 89	-1057	-4.70	7	1	21	0.53	6	0.16
5-6	2x4	38 x 89	-406	-1.81	3	1	9	0.23	2	0.06
7-17	2x4	38 x 89	1543	6.86	10	1	30	0.76	14	0.36
7-21	2x4	38 x 89	-1775	-7.90	11	1	33	0.84	11	0.27
8-21	2x4	38 x 89	389	1.73	3	1	9	0.23	4	0.09
9-21	2x4	38 x 89	-1697	-7.55	10	1	30	0.76	10	0.26
16-21	2x4	38 x 89	<250	<1.11	2	1	6	0.15	2	0.06

Several concepts required consideration when developing the model for this truss repair. One consideration was making sure the length of each member was sufficient to develop the required connection. In the case of the new top chord member from joints 3 to 4, that piece required 24" (0.61m) of development length for the OSB connection which was approximately the distance between the joints. Because of the angled cut that was required at the left end, the member was extended to the next web to create joint 6.



Repair Techniques for Metal Plated Wood Trusses
A SunCam online continuing education course

The second consideration was where to locate new webs, if needed. Modern truss software is capable of designing non-triangulated trusses, but in general, difficult trusses will work better if triangulation is achieved as was the case with this model. The web from joint 4 to 17 was added completing the triangulation of the left half of the truss, substantially improving the performance of the model.

A third consideration was the proximity of several joints in the model near the peak. In such situations, the members of the model will often fail in shear due to having joints too close together. The webs at the peak were added to alleviate this issue even though the entire region was to be covered by OSB gussets. When OSB gussets completely cover several truss members, the software model where each joint has a finite location is not as accurate and the situation requires some engineering judgement. The case could be made that since the OSB completely concealed the new members at the peak, the new webs would not be needed. However, in this case the members were included in the final repair because most of the compressive force in that region of the top chord was transferred through the horizontal member from joint 7 to 9.

Sequencing the repair steps is an important consideration when the repair involves cutting a truss. Temporary supports are often mandatory to prevent a collapse, but was not required in this case. The order of repair tasks in this case was to first cut the webs, install the new truss members, apply the OSB gussets, then lastly cut and remove the appropriate section of the top chord. This procedure allows the truss to continue to support its weight throughout the repair process maintaining a safe environment for personnel and property.



Repair Techniques for Metal Plated Wood Trusses
A SunCam online continuing education course

Example 9-3 Reverse a Web and Add HVAC Platform

Problem

An HVAC platform needs to be placed inside the truss.

Repair Drawing

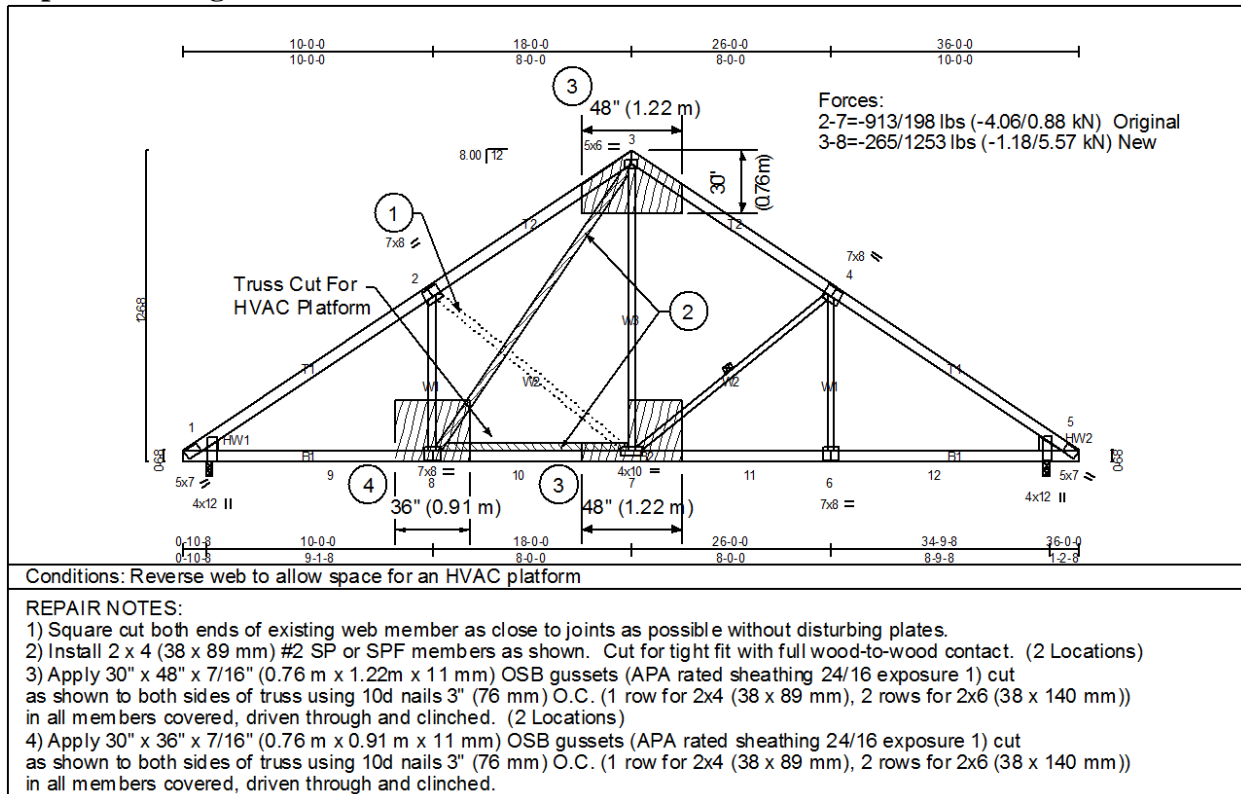

Discussion

In this case the best way to provide the needed space for the HVAC platform was to reverse the direction of the web unlike Example 8-4 where there was already a large open area in the truss where the platform could be added. According to the light attic storage provision found in Table R301.5 of the IRC2015, the open region of the truss where the HVAC unit is to be placed should be loaded with 20 psf (0.96 kN/m²). This light attic storage load is sufficient to account for most residential HVAC units and was already applied to regions of the truss from joints 9 to 10 and joints 11 to 12. The original web was predominately in compression, but with the reversed web, the controlling force in that member was 1253 lbs (5.57 kN) in tension. According to Table 3-1, the shear capacity for a clinched nail in a roof truss with OSB gussets is 173 lbs (0.77 kN) requiring eight 10d nails requiring a development length of 24" (0.61 m). The forces in other members changed as well. For example the compressive force in the top chord member from joint 2 to joint 3 changed from -1700 lbs (-7.56 kN) to -2618 lbs (-11.6 kN), but these force changes did not require in any plate size changes at any other joint. The stacked bottom chord was added as a courtesy for the builder facilitating framing of the HVAC platform but was not needed to meet the structural requirements of the truss.



Repair Techniques for Metal Plated Wood Trusses A SunCam online continuing education course

Example 9-4 Move a Floor Truss Chase

Problem

The floor truss chase is to be relocated closer to an interior bearing

Repair Drawing

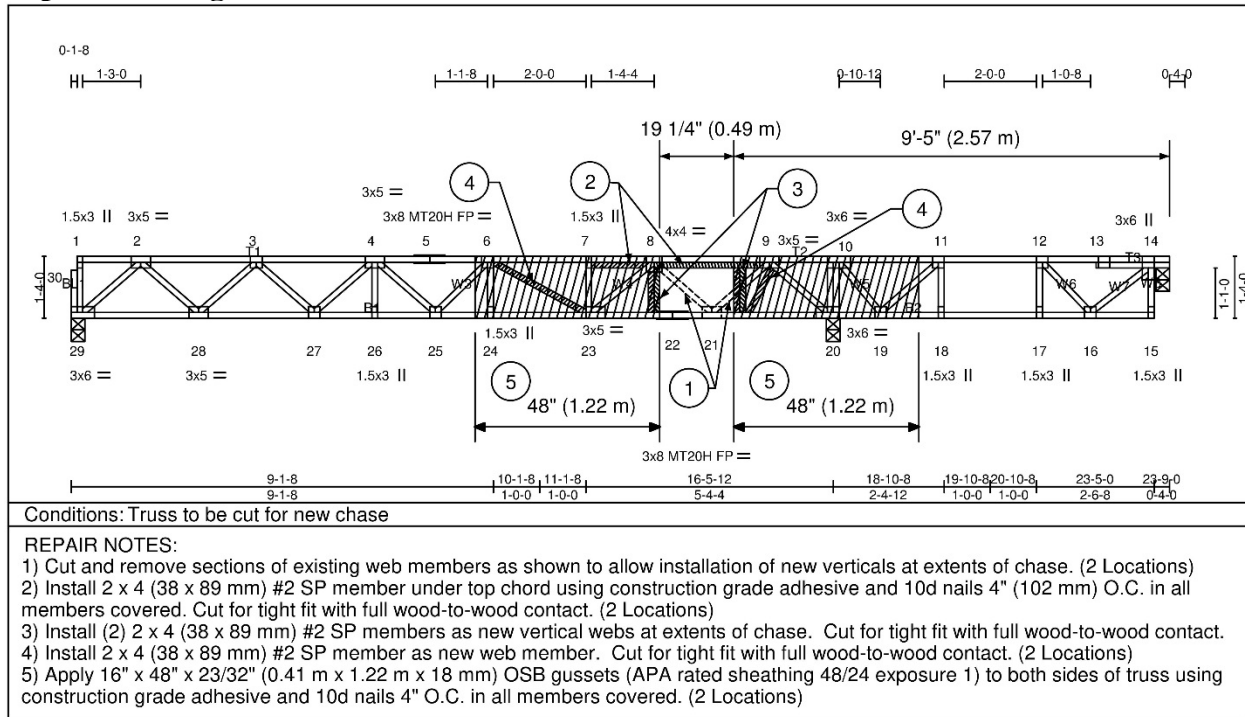

Discussion

The reason for this repair was that an adjacent floor truss was set backwards, and the chases needed alignment for passage of the ductwork. In general, the best location for a chase is in the middle of the truss span. A good rule of thumb for the best performance is that if the floor truss span were to be split into four quarters, the chase should be located within the center two quarters. When the chase is located outside that region, the shear force and differential deflection increase across the chase. The original chase was located within that ideal range between joints 6 and 7. However, the new chase location was outside the center zone, requiring a more severe repair. The remodeled truss with the revised chase location required the top chord to be doubled because of the increase in shear. The vertical webs were installed to define the chase and to provide perimeter nailing for the OSB gussets. The diagonal webs were added to provide more triangulation to improve the performance of the truss. As in Example 9-1, these diagonal webs were completely covered by the OSB gussets and an argument could be made that they are not needed, but with the new chase location in the last quarter of the span, these webs were added to increase rigidity.



Repair Techniques for Metal Plated Wood Trusses

A SunCam online continuing education course

Example 9-5 Enlarge the Room of an Attic Truss

Problem

Both the room width and height were too small for the required application.

Repair Drawing

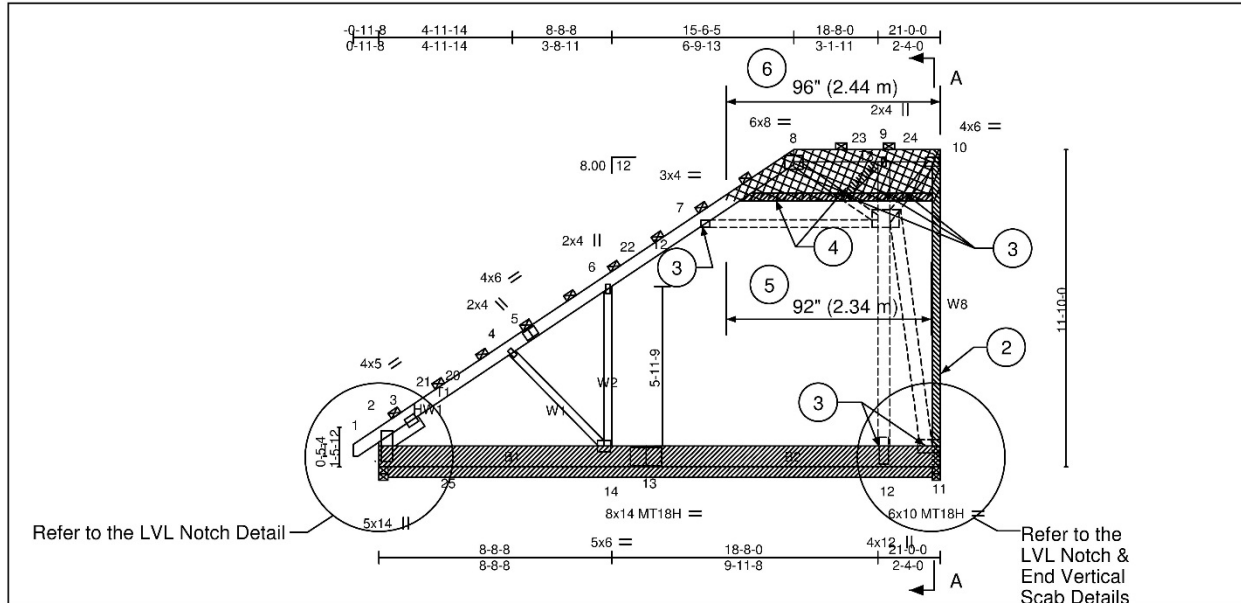

Conditions: The height of the attic room is to be increased to 9' and the width to 12'.

REPAIR NOTES:

- 1) Install either 2-ply 1 1/2" x 14" (38 x 356 mm) truss grade LVL or 2-ply 1 3/4" x 14" (44 x 356 mm) 2.0 E LVL scab to the front side of existing bottom chord member. Attach scabs using (3) rows Simpson 1/4" x 6" (6.4 x 152 mm) SDS or SDW screws spaced 12" (0.30 m) O.C. from both sides per the Two Ply LVL Connection detail. Stagger screws from opposite side. Refer to the LVL Notch Detail for the end cuts at both ends. Scab length = 21' (6.40 m).
- 2) Install 2 x 4 (38 x 89 mm) #1 SP scab to the back side (opposite of LVL scab) of existing end vertical member. Connect scab to 2 x 10 (38 x 235 mm) bottom chord using (11) 10d nails per the Vertical Scab Detail. Otherwise, attach scab using 10d nails spaced 3" O.C. Scab length = 11' -10" (3.61 m).
- 3) Cut and remove existing members as shown to facilitate installation of new ceiling chord member. (6 Locations)
- 4) Install 2-ply 2 x 4 (38 x 89 mm) #2 SP member as new web member. Cut for tight fit with full wood-to-wood contact. Connect plies together using 1 row 10d nails 9" (229 mm) o.c. (2 Locations)
- 5) Apply 22" x 92" x 7/16" (0.56 m x 2.34 m x 11 mm) OSB gusset (APA rated sheathing 24/16 exposure 1) cut as shown to the back side of the truss using 10d nails 3" (76 mm) O.C. (1 row for 2x4 (38 x 89 mm), 2 rows for 2x6 (38 x 140 mm)) in all members covered.
- 6) Apply 22" x 96" x 7/16" (0.56 m x 2.34 m x 11 mm) OSB gussets (APA rated sheathing 24/16 exposure 1) cut as shown the front side of truss using 10d nails 3" (76 mm) O.C. (1 row for 2x4 (38 x 89 mm), 2 rows for 2x6 (38 x 140 mm)) in all members covered.

Discussion

This repair involved a 2-ply truss located on either side of a dormer where the attic area continued to the left end of the truss. This truss was part of a series of mostly single ply attic trusses with the same profile where the room was similarly undersized. Since the whole series of trusses was affected, a small drop in the ceiling height was considered an option to resolve the issue. The revised truss and associated repair details are shown on the following pages.



Repair Techniques for Metal Plated Wood Trusses
A SunCam online continuing education course

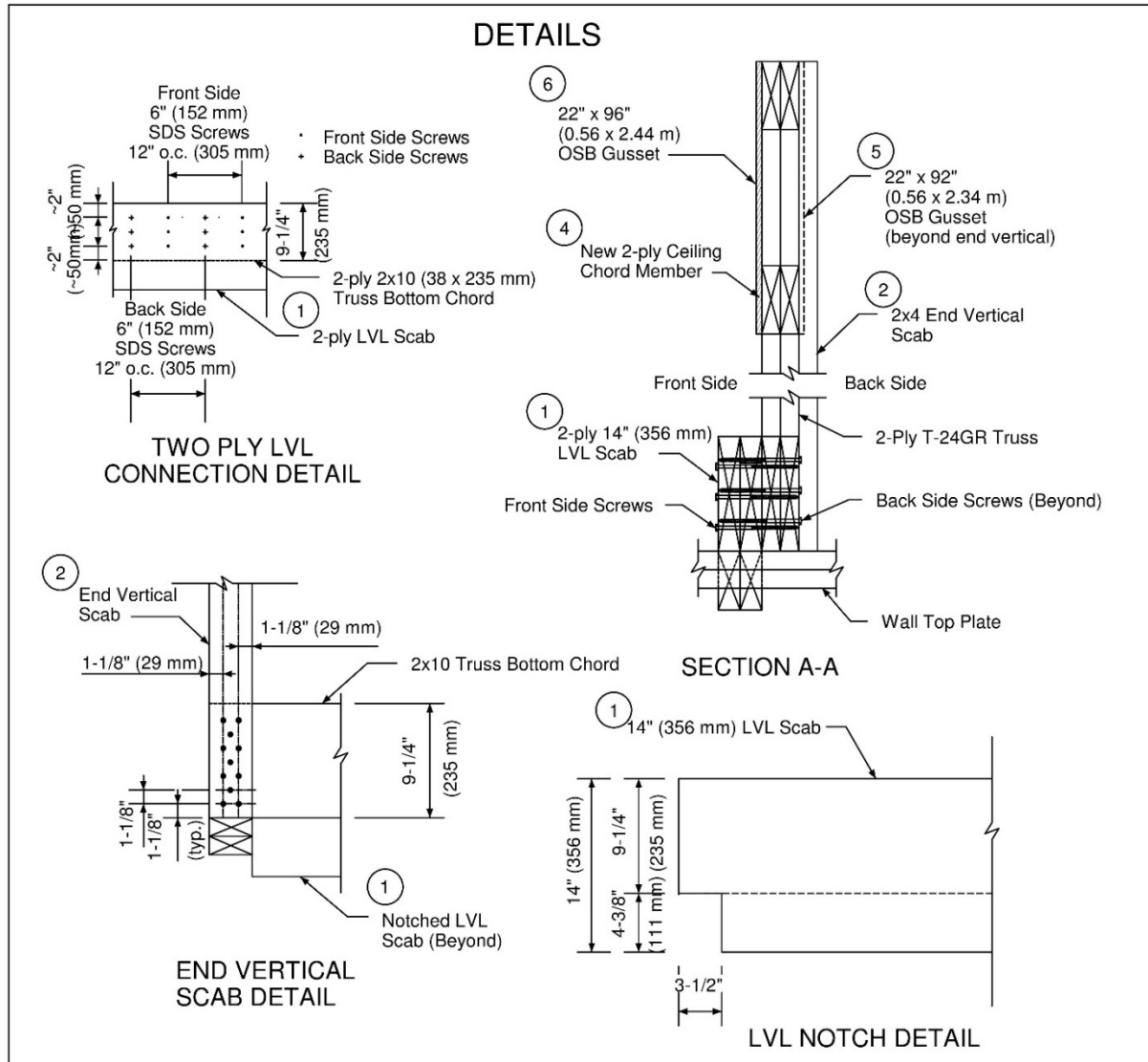

Remodeling of the 2-ply dormer girder truss with the adjusted loads and larger room showed some of the forces in the members actually reduced because of a conservative original design. The modification to this truss was still substantial and the extra details shown above were provided to insure proper installation. The bending stress in the bottom chord increased beyond acceptable limits for a 2x10 (38 x 235 mm) bottom chord. After negotiations with the affected parties, it was determined that best solution was to sacrifice some ceiling height below the trusses in a room that already had a 9' (2.74 m) ceiling rather than replace the trusses at that stage of construction. The 14" (356 mm) LVL material provided the required strength for the larger room. The LVL material was available in long enough lengths that there was no need for splice in the bottom chord.



Repair Techniques for Metal Plated Wood Trusses A SunCam online continuing education course

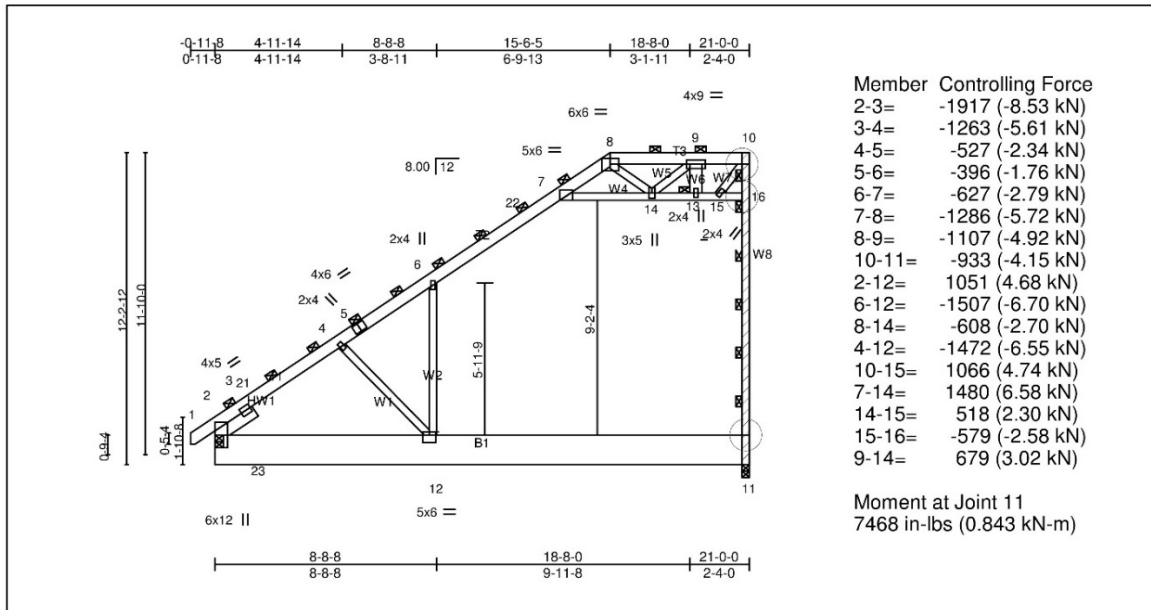

The end vertical member was the next most critical area to consider. The actual controlling tension force in the bottom chord and compression force in the end vertical member were relatively small. However, the revised model reported a moment at joint 11 of 7468 in•lbs (0.843 kN•m) which generated a bending failure in the end vertical member. In this model, the single scab was sufficient to reinforce the end vertical but could not develop the required moment connection given the geometry of the joint. Upon further review, the undamaged portion of the original truss plate was able to transfer most of moment and needed only a little reinforcement to finish the task. It was decided to apply the two bottom chord scabs to one side of the bottom chord and the end vertical scab to the other as shown in Section A-A. The end vertical scab overlapped the bottom chord allowing for the modest moment connection (as shown in the End Vertical Scab Detail) to reinforce the remaining truss plate. Part 3 of this course series will have a more in-depth discussion of developing a moment connection.

The revised model required the end vertical scab to go the full length of the member including the section above the new attic ceiling. This model also required two small webs to be added above the new ceiling member. However, the lengths were insufficient to develop the full connection requirements for separate gussets at each joint. The solution was to apply one 92” (2.34 m) wide OSB gusset on the same face as the end vertical scab and one 96” (2.44 m) wide OSB gusset on the opposite face that extended to the right end of the truss allowing for full perimeter nailing for that piece.

It is incumbent on the engineer to know the software limitations before attempting this type of complicated model. In this case, the software was not able to calculate capacity of the LVL material with the notch or to determine a suitable truss plate for the three joints along the end vertical. These items had to be considered in other software packages or through manual calculations.



Repair Techniques for Metal Plated Wood Trusses
A SunCam online continuing education course

Example 9-6 Cut Out Bottom Chord for Pull-Down Stair

Problem

The required pull-down stair opening is wider than the spacing between the trusses. A section of the bottom chord must be cut and removed from the T-03B truss.

Repair Drawing

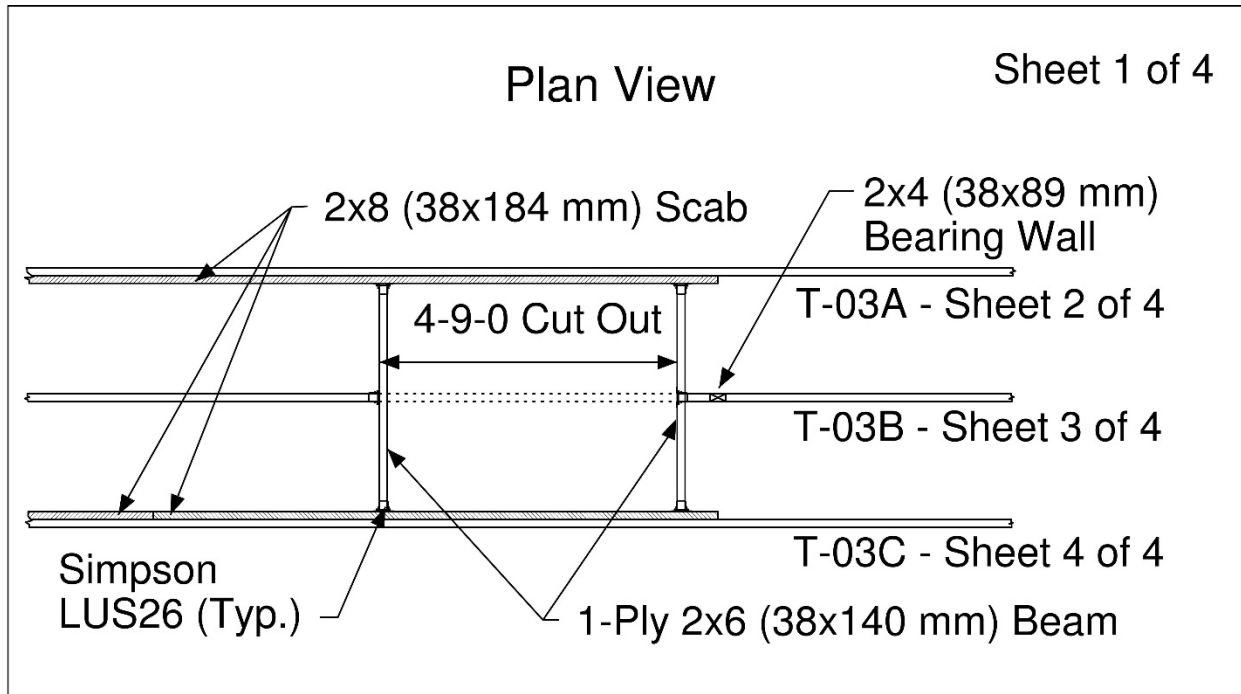

Discussion

The issue of requiring a larger opening than the 22 1/2" (0.57 m) clear space between trusses for the pull-down stairs is fairly common. The error could have been made by the framers if they missed the special spacing requirement, by the truss design team for not specifying the location on the truss placement plan, or by the building designer for not locating the pull-down stairs prior to truss erection. On occasion, the long dimension of the stair opening may actually be perpendicular to the trusses requiring two or more trusses to be cut. The general principle of the repair is to cut the necessary portion of the bottom chord, use hangers on a beam to support the cut portions of the truss, and support the beams on the adjacent trusses using hangers.

This repair involved three different trusses: the one being cut for the opening and the two that support the beams. The repairs to all three trusses are presented as part of this example along with a plan view shown above.



Repair Techniques for Metal Plated Wood Trusses
 A SunCam online continuing education course

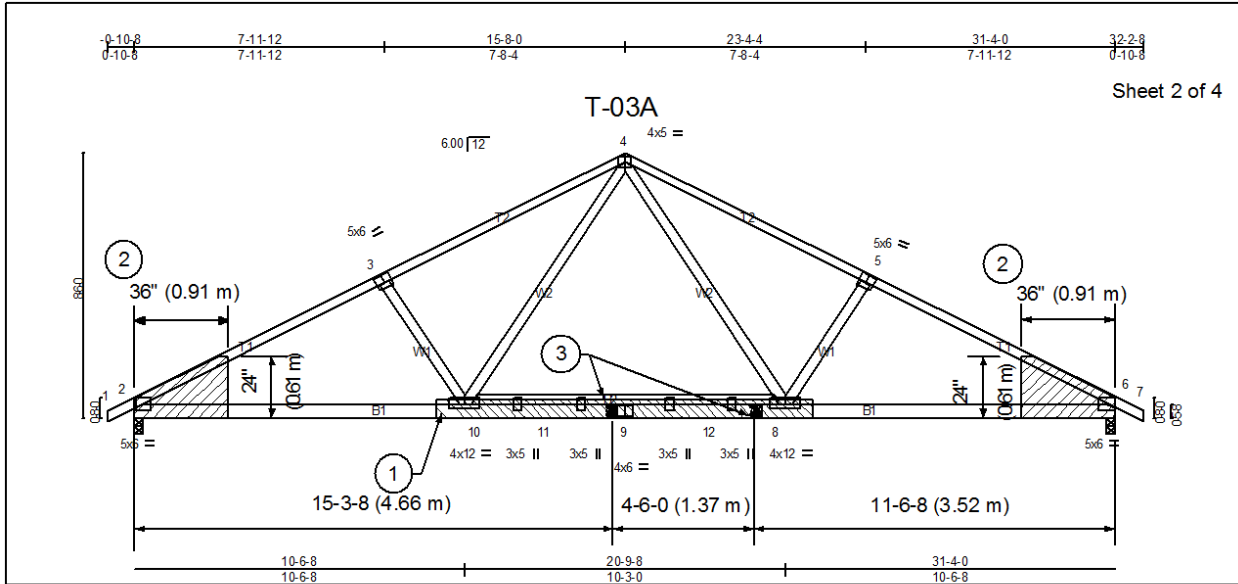

Sheet 2 of 4

Conditions: Truss support load from adjacent T-03B

REPAIR NOTES:

- 1) Install 2 x 8 (38 x 184 mm) #2 SP scab to one side of existing bottom chord member. Attach scab using 3 rows 10d nails spaced 6" (152 mm) O.C. Scab length = 12' (3.66 m).
- 2) Apply 24" x 36" x 7/16" (0.61 m x 0.91 m x 11 mm) OSB gussets (APA rated sheathing 24/16 exposure 1) cut as shown to both sides of truss using 10d nails 3" (76 mm) O.C. (1 row for 2x4 (38x89 mm), 2 rows for 2x6 (38x140 mm)) in all members covered, driven through and clinched. (2 Locations)
- 3) Support 1-ply 2x6 (38x140 mm) #2 SP or SPF beam using Simpson LUS26 Hanger or equivalent. (2 Locations)

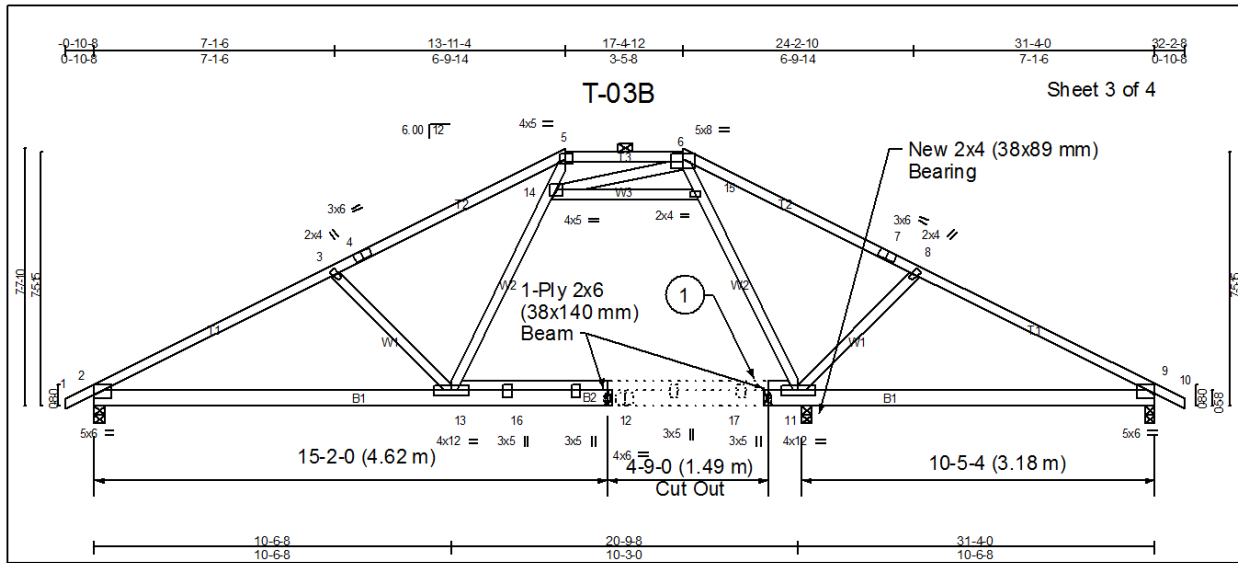

Sheet 3 of 4

Conditions: Truss to be cut for pull-down stair

REPAIR NOTES:

- 1) 4-9-0 (1.49 m) Section of bottom chord may be square cut and removed as shown. Ensure existing lumber and plates are cut cleanly and accurately and remaining plating is left fully embedded and completely undisturbed. Bottom chord to be supported using Simpson LUS26 Hangers or equivalent as connection to 1-ply 2x6 (38x140 mm) #2 SP or SPF beams. See attached Sheets 2 and 4 for details concerning beam connection to neighboring T-03A and T-03C trusses.



Repair Techniques for Metal Plated Wood Trusses
A SunCam online continuing education course

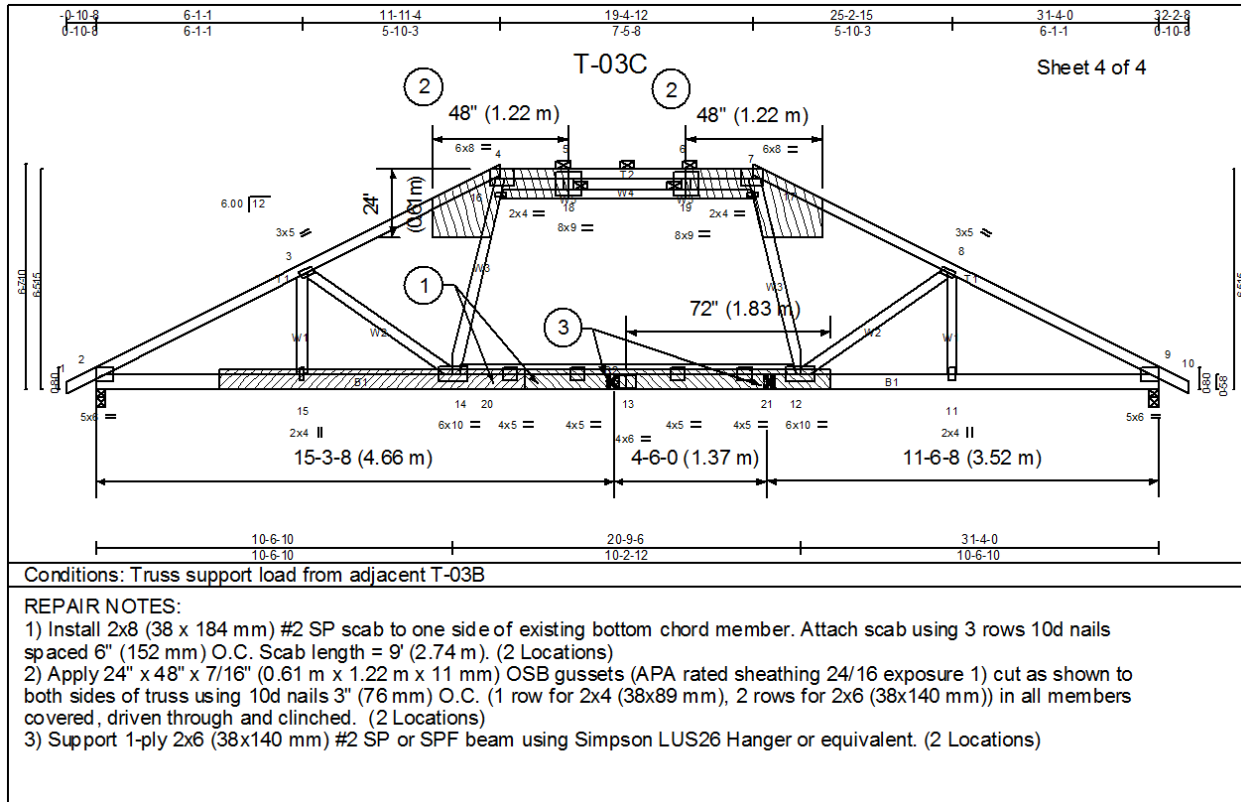

In this case there were three different trusses involved in the repair (T-03A, T-03B, & T-03C). T-03B is the truss to be cut. T-03A and T-03C are the trusses redesigned to support the new beams. A plan view detail along with a repair drawing for each truss involved are shown above. The modifications of each truss were modeled inside the truss software. The builder was also able to provide a 2x4 (38x89 mm) bearing wall at joint 11 for T-03B. With the new bearing wall and the beam supporting the other end of the opening, no additional changes were required because the effective span of the truss had been reduced and the forces in the members were smaller than the original design.

The new loads imposed on T-03A and T-03C caused some plates and lumber to be undersized. T-03A required reinforcement at the heel joints and T-03C required reinforcement at the top chord joints 4 and 7 and along the bottom chord between joints 14 and 15. Also, both trusses required reinforcement in the area of the bottom chord where the hangers were attached.



Repair Techniques for Metal Plated Wood Trusses
A SunCam online continuing education course

Example 9-7 Cut Out Bottom Chord for Pull-Down Stair – Alternate Design

Problem

The required pull-down stair opening is wider than the spacing between the trusses. A section of the bottom chord must be cut and removed from the T-09C truss.

Repair Drawing

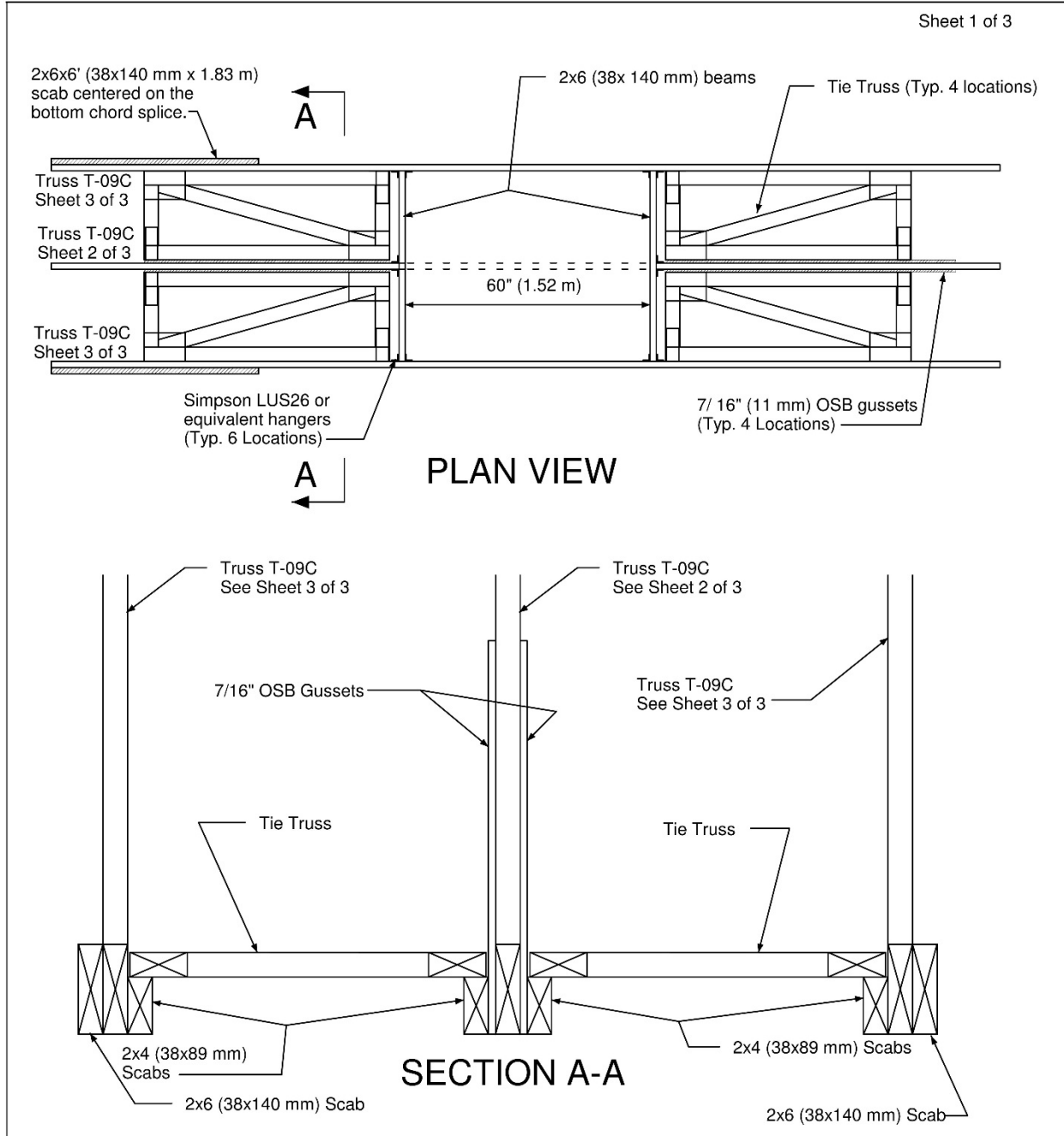



Repair Techniques for Metal Plated Wood Trusses

A SunCam online continuing education course

Sheet 2 of 3

Conditions: Truss to be cut for attic access

REPAIR NOTES:

- 1) Square cut end of existing web member as close to the joint as possible without disturbing plates. Remove web member.
- 2) Install 2 x 4 (38 x 89 mm) #2 SP web as shown. Cut for tight fit with full wood-to-wood contact. (3 Locations)
- 3) Apply 24" x 48" x 7/16" (0.61 m x 1.22 m x 11 mm) OSB gussets (APA rated sheathing 24/16 exposure 1) cut as shown to both sides of truss using 10d nails 3" (76 mm) O.C. in all members covered, driven through and clinched.
- 4) Apply 24" x 36" x 7/16" (0.61 m x 0.91 m x 11 mm) OSB gussets (APA rated sheathing 24/16 exposure 1) cut as shown to both sides of truss using 10d nails 3" (76 mm) O.C. in all members covered, driven through and clinched. Along the bottom chord, the gusset should be connected using (1) row of 10d nails about one inch down from the top of the bottom chord to allow for future scabs. (2 Locations)
- 5) Apply 5-1/2" x 7/16" (140 x 11 mm) OSB gussets (APA rated sheathing 24/16 exposure 1) cut as shown to both sides of truss. Gussets are to be used as fillers for the scabs that follow. Tack gussets in place. (2 Locations)
- 6) Apply 30" x 36" x 7/16" (0.76 m x 0.91 m x 11 mm) OSB gussets (APA rated sheathing 24/16 exposure 1) cut as shown to both sides of truss using 10d nails 3" (76 mm) O.C. in all members covered, driven through and clinched.
- 7) Install 2 x 4 (38 x 89 mm) #2 SP scabs to both sides of existing bottom chord member. Attach scabs to the bottom chord through the OSB gussets using 10d nails spaced 3" (76 mm) O.C. Scab length = 5' (1.52 m). (2 Locations)
- 8) Fabricate 4 Tie trusses. Lay tie trusses flat and attach the tie trusses to the above scabs using 10d nails 3" (76 mm) O.C. in the top of the 2 x 4 (38 x 89 mm) scabs mentioned in note 7. Refer to the Details page, Sheet 1 of 3, for more information regarding the installation of the Tie trusses.
- 9) Sections of existing truss may be cut out to provide the required opening ONLY after all of the above repair steps have been performed.
- 10) Install 2 x 6 (38 x 140 mm) #2 SP or SPF as a beam between the two adjacent trusses. Connect the bottom chord of the truss to each 2 x 6 (38 x 140 mm) beam using a Simpson LUS26 or equivalent hanger. (2 Locations)

Discussion

This repair accomplishes the same goal as Example 9-6 by allowing a section of the bottom chord of the truss to be removed, but the method presented in this example relies on a completely different concept. In Example 9-6 the cut truss was essentially modeled as two half trusses where the vertical reactions were transferred to and supported by the adjacent trusses. However, this example considered the direction of force in the bottom chord member and used a system concept as opposed to an individual truss design to allow the adjacent trusses to share the load. The predominant force in the bottom chord member was tension which was in the horizontal direction due to the orientation of the member. The primary concept in this repair was that the tension force of the cut truss is transferred horizontally so that the bottom chord members of the adjacent trusses can share the tension force. As a system concept, there were three individual trusses before one truss was cut; now there are two bottom chord members carrying the tension load of three in the region of the interruption. This repair concept is only effective when the adjacent bottom chord members have excess CSI capacity to take up the extra load.



Repair Techniques for Metal Plated Wood Trusses
A SunCam online continuing education course

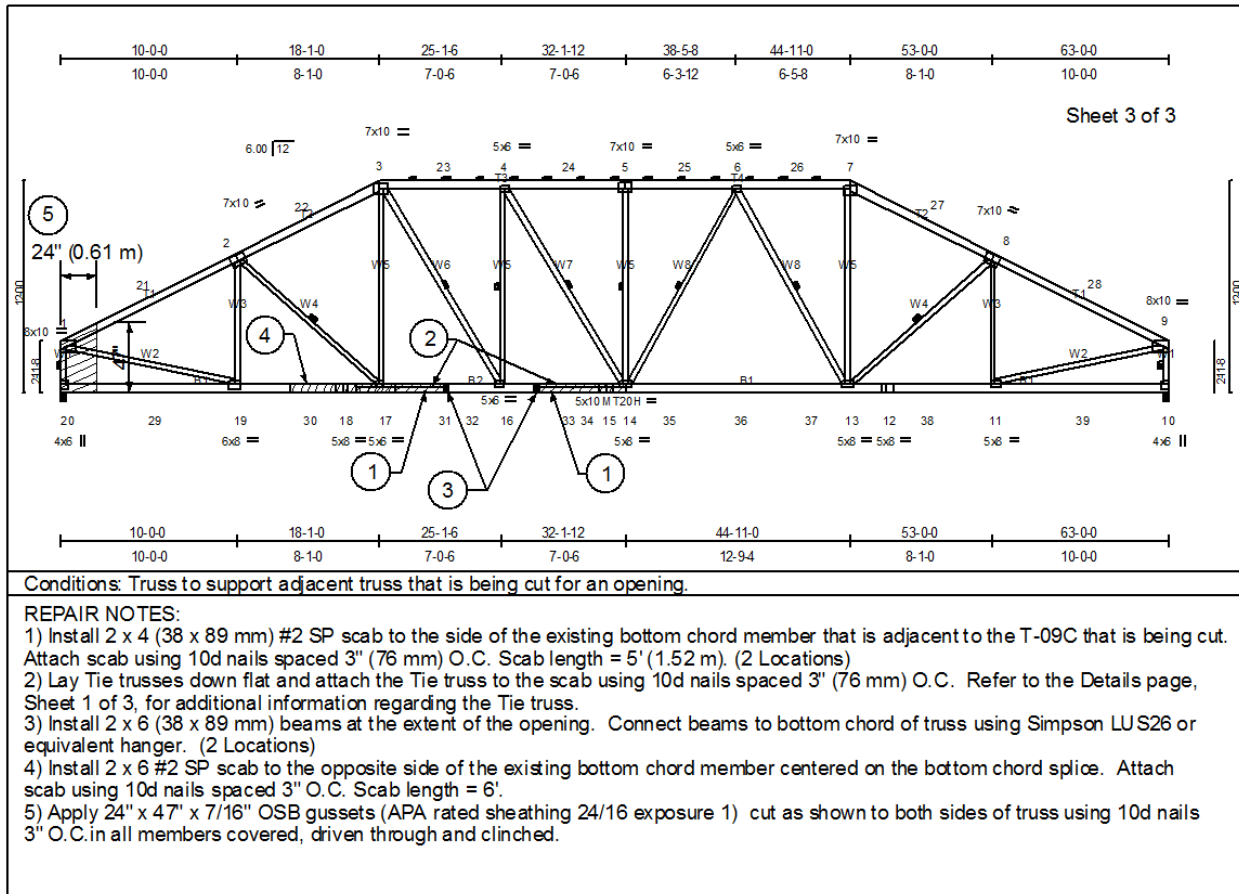

In order for the adjacent bottom chord members to share the load, a mechanism must be designed to transfer the tension force. The concept of transferring a lateral force through a truss is not new. Trusses are regularly used to transfer shear loads down through the structure. The only difference here is that the tie truss is oriented horizontally rather than the traditional vertical orientation for shear transfer. For this repair a tie truss was designed to transfer the 3,506 lbs (15.60 kN) of tension force found in the modified T-09C to the adjacent trusses. The height of the tie truss is determined by the clear space between the trusses minus a little for working space and the length is controlled by the development length of the connection to transfer the tension force. In this case the height of the tie truss is 1'-9 3/4" (0.55 m) x 5' (1.52 m) long. As shown in the details, four of the tie trusses were manufactured and shipped to the jobsite to accomplish the goal of sharing the load.



Repair Techniques for Metal Plated Wood Trusses
A SunCam online continuing education course

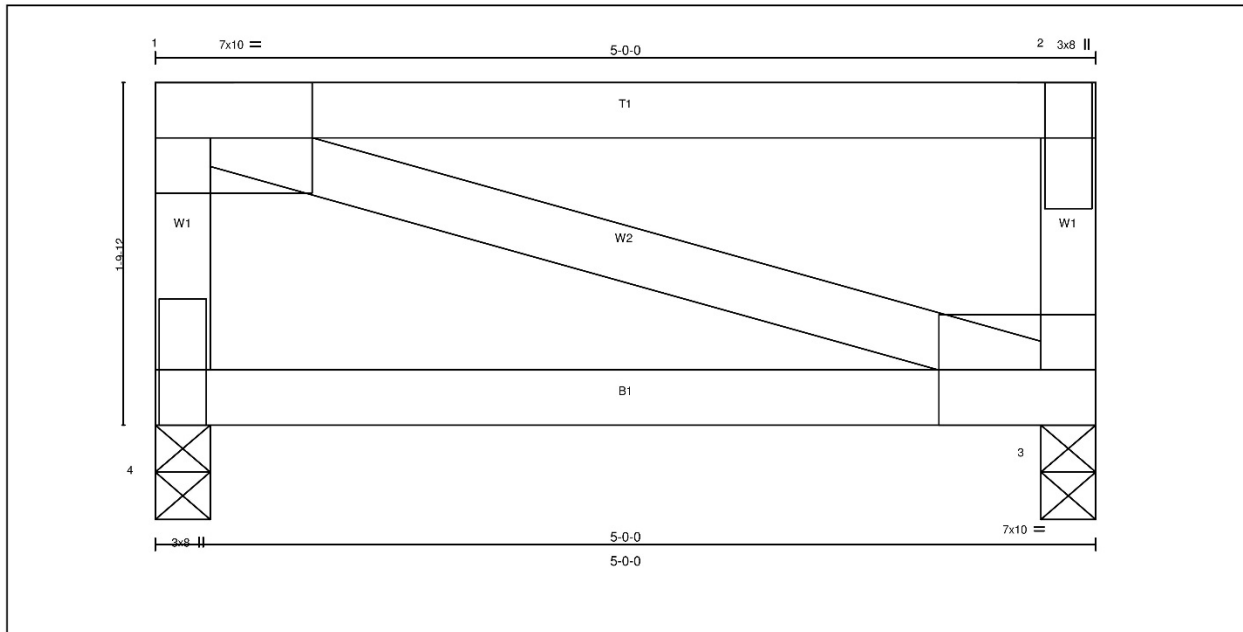

On the cut truss, bearings were placed at the extent of the opening, designed as vertical rollers. The remaining two bearings at the extents of the truss were designed as horizontal rollers. This can be seen in the reactions of the Modified T-09C truss. The vertical reactions were zero at joints 16 and 17 while the horizontal reactions were zero at joints 10 and 21. Due to the fact that this truss was 63' (19.20 m) long, the model did not work with the cut and the vertical rollers, so additional webs were needed to complete the triangulation and get the truss to pass the structural test. These new webs are shown on both the modified T-09C truss graphic and the Sheet 2 of 3 of the actual repair.

The supporting trusses performed well in the model with the extra load except for a minor plate change at the left heel. It is the policy of this truss manufacturer to use a minimum 2x6 (38x140 mm) chord for trusses with a span of 45' (13.72 m) or longer. Because of the larger chord size, the nice regular shape, the height of the truss, and the triangulated webbing, the Combined Stress Index (CSI) in that region of the bottom chord was only 0.29. With a CSI that low, each supporting truss was easily able absorb the extra load.



Repair Techniques for Metal Plated Wood Trusses A SunCam online continuing education course

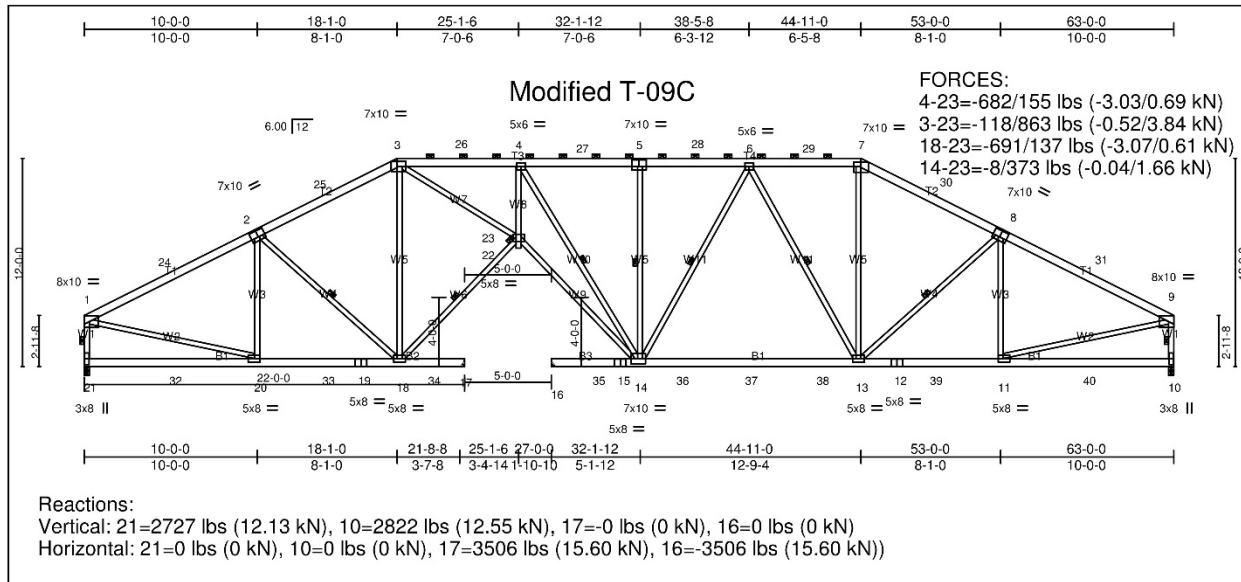

The 5' (1.52 m) long 2x4 (38x89 mm) scab applied to both the cut truss and the supporting trusses act as a little ledge to lay the tie truss flat which provides a good connection to each of the T-09C trusses. There is also a 2x6 (38x140 mm) beam at the extent of the opening connected with hangers. In this example, the 2x6 (38x140 mm) member acts to transfer nominal vertical loads and, more importantly, force the three trusses to deflect together and act as a unit.

Both the vertical load distribution method discussed in Example 9-6 and the horizontal load distribution method discussed here are effective methods of allowing the pull-down stairs to penetrate the truss. Due to the long span of the trusses in this example, the horizontal tie truss repair was the most cost effective solution. The traditional vertical load transfer with the beams is an alternative solution in more time sensitive cases because of the time to manufacture the tie trusses.



Repair Techniques for Metal Plated Wood Trusses
A SunCam online continuing education course

Conclusion

The purpose of this course series has been to examine various techniques and approaches to repairing, reinforcing, or modifying metal plated wood trusses. While most repairs are fairly straight forward and can use standard repair methods such as lumber scabs and OSB gussets, a small portion of the repairs and modifications are more complex. This course series provides a broad spectrum of the possible situations and suggested solutions for truss alterations.

This document is the second part in the three part series and has focused on truss repairs of moderate complexity. The discussion began with a presentation of manufacturing errors, followed by stubs and extensions, minor modifications which involved adding new members to the truss and ending with major modifications which comprised those repairs that involved removing some portion of the original truss. The first part of the course series included definitions of terms and a discussion of simple repairs. The final part will include a more detailed description of a limited number of very complex repairs.

References and Notes:

- I first want to thank Mr. Mike Fuss PE for being a mentor and friend. There have been many hours spent discussing truss repairs, and I have learned a lot from him. Mike is now enjoying retirement. Thanks Mike!
- The repair sketches in this document were originally prepared by Ms. Christine Cavanaugh or Mr. Bryon DeGraw and have all been modified from the original truss repairs for this document
- The truss designs presented in this document were all produced using the Engineering software and all repair sketches were made in the accompanying CAD software both developed by Mitek Industries Incorporated of Chesterfield, MO.
- National Design Standard for Metal Plate Connected Wood Truss Construction, ANSI/TPI 1-2014, published by Truss Plate Institute (TPI), Madison WI, 2014.
- American Forest and Paper Association, AF&PA, National Design Specification, NDS-2015 & supplement, published by American Wood Council of Leesburg, VA, 2016.
- International Residential Code 2012 for One- and Two-Family Dwellings (IRC2015), published by the International Code Council of Washington, D.C., 2015.
- Simpson C-C-2015 catalogue, Simpson Strong-Tie, Pleasanton, CA, 2013.
- Manual for Engineered Wood Construction, 2015 Edition, American Wood Council, Leesburg, VA, 2016.